

GENERAL DESCRIPTION

List of Diagnostic Trouble Code (DTC)

GENERAL DESCRIPTION

1. List of Diagnostic Trouble Code (DTC)

A: LIST

DTC	Description	Index
P0011	Intake Camshaft Position - Timing Over-advanced Or System Performance (Bank 1)	<Ref. to GD(H4DOTC)-10, DTC P0011 INTAKE CAMSHAFT POSITION - TIMING OVER-ADVANCED OR SYSTEM PERFORMANCE (BANK 1), Diagnostic Trouble Code (DTC) Detecting Criteria.>
P0016	Crankshaft Position - Camshaft Position Correlation (Bank 1)	<Ref. to GD(H4DOTC)-12, DTC P0016 CRANKSHAFT POSITION - CAMSHAFT POSITION CORRELATION (BANK 1), Diagnostic Trouble Code (DTC) Detecting Criteria.>
P0018	Crankshaft Position - Camshaft Position Correlation (Bank 2)	<Ref. to GD(H4DOTC)-12, DTC P0018 CRANKSHAFT POSITION - CAMSHAFT POSITION CORRELATION (BANK 2), Diagnostic Trouble Code (DTC) Detecting Criteria.>
P0021	Intake Camshaft Position - Timing Over-advanced Or System Performance (Bank 2)	<Ref. to GD(H4DOTC)-12, DTC P0021 INTAKE CAMSHAFT POSITION - TIMING OVER-ADVANCED OR SYSTEM PERFORMANCE (BANK 2), Diagnostic Trouble Code (DTC) Detecting Criteria.>
P0030	HO2S Heater Control Circuit (Bank 1 Sensor 1)	<Ref. to GD(H4DOTC)-13, DTC P0030 HO2S HEATER CONTROL CIRCUIT (BANK 1 SENSOR 1), Diagnostic Trouble Code (DTC) Detecting Criteria.>
P0031	HO2S Heater Control Circuit Low (Bank 1 Sensor 1)	<Ref. to GD(H4DOTC)-15, DTC P0031 HO2S HEATER CONTROL CIRCUIT LOW (BANK 1 SENSOR 1), Diagnostic Trouble Code (DTC) Detecting Criteria.>
P0032	HO2S Heater Control Circuit High (Bank 1 Sensor 1)	<Ref. to GD(H4DOTC)-17, DTC P0032 HO2S HEATER CONTROL CIRCUIT HIGH (BANK 1 SENSOR 1), Diagnostic Trouble Code (DTC) Detecting Criteria.>
P0037	HO2S Heater Control Circuit Low (Bank 1 Sensor 2)	<Ref. to GD(H4DOTC)-19, DTC P0037 HO2S HEATER CONTROL CIRCUIT LOW (BANK 1 SENSOR 2), Diagnostic Trouble Code (DTC) Detecting Criteria.>
P0038	HO2S Heater Control Circuit High (Bank 1 Sensor 2)	<Ref. to GD(H4DOTC)-21, DTC P0038 HO2S HEATER CONTROL CIRCUIT HIGH (BANK 1 SENSOR 2), Diagnostic Trouble Code (DTC) Detecting Criteria.>
P0068	Manifold Pressure Sensor Range/Performance	<Ref. to GD(H4DOTC)-23, DTC P0068 MANIFOLD PRESSURE SENSOR RANGE/PERFORMANCE, Diagnostic Trouble Code (DTC) Detecting Criteria.>
P0101	Mass or Volume Air Flow Circuit Range/Performance	<Ref. to GD(H4DOTC)-25, DTC P0101 MASS OR VOLUME AIR FLOW CIRCUIT RANGE/PERFORMANCE, Diagnostic Trouble Code (DTC) Detecting Criteria.>
P0102	Mass or Volume Air Flow Circuit Low Input	<Ref. to GD(H4DOTC)-28, DTC P0102 MASS OR VOLUME AIR FLOW CIRCUIT LOW INPUT, Diagnostic Trouble Code (DTC) Detecting Criteria.>
P0103	Mass or Volume Air Flow Circuit High Input	<Ref. to GD(H4DOTC)-30, DTC P0103 MASS OR VOLUME AIR FLOW CIRCUIT HIGH INPUT, Diagnostic Trouble Code (DTC) Detecting Criteria.>
P0107	Manifold Absolute Pressure/Barometric Pressure Circuit Low Input	<Ref. to GD(H4DOTC)-32, DTC P0107 MANIFOLD ABSOLUTE PRESSURE/BAROMETRIC PRESSURE CIRCUIT LOW INPUT, Diagnostic Trouble Code (DTC) Detecting Criteria.>
P0108	Manifold Absolute Pressure/Barometric Pressure Circuit High Input	<Ref. to GD(H4DOTC)-34, DTC P0108 MANIFOLD ABSOLUTE PRESSURE/BAROMETRIC PRESSURE CIRCUIT HIGH INPUT, Diagnostic Trouble Code (DTC) Detecting Criteria.>
P0111	Intake Air Temperature Circuit Range/Performance	<Ref. to GD(H4DOTC)-36, DTC P0111 INTAKE AIR TEMPERATURE CIRCUIT RANGE/PERFORMANCE, Diagnostic Trouble Code (DTC) Detecting Criteria.>
P0112	Intake Air Temperature Circuit Low Input	<Ref. to GD(H4DOTC)-38, DTC P0112 INTAKE AIR TEMPERATURE CIRCUIT LOW INPUT, Diagnostic Trouble Code (DTC) Detecting Criteria.>
P0113	Intake Air Temperature Circuit High Input	<Ref. to GD(H4DOTC)-40, DTC P0113 INTAKE AIR TEMPERATURE CIRCUIT HIGH INPUT, Diagnostic Trouble Code (DTC) Detecting Criteria.>
P0117	Engine Coolant Temperature Circuit Low Input	<Ref. to GD(H4DOTC)-42, DTC P0117 ENGINE COOLANT TEMPERATURE CIRCUIT LOW INPUT, Diagnostic Trouble Code (DTC) Detecting Criteria.>

List of Diagnostic Trouble Code (DTC)

GENERAL DESCRIPTION

DTC	Description	Index
P0118	Engine Coolant Temperature Circuit High Input	<Ref. to GD(H4DOTC)-44, DTC P0118 ENGINE COOLANT TEMPERATURE CIRCUIT HIGH INPUT, Diagnostic Trouble Code (DTC) Detecting Criteria.>
P0122	Throttle/Pedal Position Sensor/Switch "A" Circuit Low Input	<Ref. to GD(H4DOTC)-46, DTC P0122 THROTTLE/PEDAL POSITION SENSOR/SWITCH "A" CIRCUIT LOW INPUT, Diagnostic Trouble Code (DTC) Detecting Criteria.>
P0123	Throttle/Pedal Position Sensor/Switch "A" Circuit High Input	<Ref. to GD(H4DOTC)-47, DTC P0123 THROTTLE/PEDAL POSITION SENSOR/SWITCH "A" CIRCUIT HIGH INPUT, Diagnostic Trouble Code (DTC) Detecting Criteria.>
P0125	Insufficient Coolant Temperature For Closed Loop Fuel Control	<Ref. to GD(H4DOTC)-49, DTC P0125 INSUFFICIENT COOLANT TEMPERATURE FOR CLOSED LOOP FUEL CONTROL, Diagnostic Trouble Code (DTC) Detecting Criteria.>
P0126	Insufficient Coolant Temperature For Stable Operation	<Ref. to GD(H4DOTC)-51, DTC P0126 INSUFFICIENT COOLANT TEMPERATURE FOR STABLE OPERATION, Diagnostic Trouble Code (DTC) Detecting Criteria.>
P0128	Coolant Thermostat (Coolant Temperature Below Thermostat Regulating Temperature)	<Ref. to GD(H4DOTC)-53, DTC P0128 COOLANT THERMOSTAT (COOLANT TEMPERATURE BELOW THERMOSTAT REGULATING TEMPERATURE), Diagnostic Trouble Code (DTC) Detecting Criteria.>
P0131	O ₂ Sensor Circuit Low Voltage (Bank 1 Sensor 1)	<Ref. to GD(H4DOTC)-55, DTC P0131 O ₂ SENSOR CIRCUIT LOW VOLTAGE (BANK 1 SENSOR 1), Diagnostic Trouble Code (DTC) Detecting Criteria.>
P0132	O ₂ Sensor Circuit High Voltage (Bank 1 Sensor 1)	<Ref. to GD(H4DOTC)-57, DTC P0132 O ₂ SENSOR CIRCUIT HIGH VOLTAGE (BANK 1 SENSOR 1), Diagnostic Trouble Code (DTC) Detecting Criteria.>
P0133	O ₂ Sensor Circuit Slow Response (Bank 1 Sensor 1)	<Ref. to GD(H4DOTC)-58, DTC P0133 O ₂ SENSOR CIRCUIT SLOW RESPONSE (BANK 1 SENSOR 1), Diagnostic Trouble Code (DTC) Detecting Criteria.>
P0134	O ₂ Sensor Circuit No Activity Detected (Bank 1 Sensor 1)	<Ref. to GD(H4DOTC)-61, DTC P0134 O ₂ SENSOR CIRCUIT NO ACTIVITY DETECTED (BANK 1 SENSOR 1), Diagnostic Trouble Code (DTC) Detecting Criteria.>
P0137	O ₂ Sensor Circuit Low Voltage (Bank 1 Sensor 2)	<Ref. to GD(H4DOTC)-62, DTC P0137 O ₂ SENSOR CIRCUIT LOW VOLTAGE (BANK 1 SENSOR 2), Diagnostic Trouble Code (DTC) Detecting Criteria.>
P0138	O ₂ Sensor Circuit High Voltage (Bank 1 Sensor 2)	<Ref. to GD(H4DOTC)-64, DTC P0138 O ₂ SENSOR CIRCUIT HIGH VOLTAGE (BANK 1 SENSOR 2), Diagnostic Trouble Code (DTC) Detecting Criteria.>
P0139	O ₂ Sensor Circuit Slow Response (Bank 1 Sensor 2)	<Ref. to GD(H4DOTC)-65, DTC P0139 O ₂ SENSOR CIRCUIT SLOW RESPONSE (BANK 1 SENSOR 2), Diagnostic Trouble Code (DTC) Detecting Criteria.>
P0140	O ₂ Sensor Circuit No Activity Detected (Bank 1 Sensor 2)	<Ref. to GD(H4DOTC)-71, DTC P0140 O ₂ SENSOR CIRCUIT NO ACTIVITY DETECTED (BANK 1 SENSOR 2), Diagnostic Trouble Code (DTC) Detecting Criteria.>
P0171	System Too Lean (Bank 1)	<Ref. to GD(H4DOTC)-72, DTC P0171 SYSTEM TOO LEAN (BANK 1), Diagnostic Trouble Code (DTC) Detecting Criteria.>
P0172	System Too Rich (Bank 1)	<Ref. to GD(H4DOTC)-74, DTC P0172 SYSTEM TOO RICH (BANK 1), Diagnostic Trouble Code (DTC) Detecting Criteria.>
P0181	Fuel Temperature Sensor "A" Circuit Range/Performance	<Ref. to GD(H4DOTC)-77, DTC P0181 FUEL TEMPERATURE SENSOR "A" CIRCUIT RANGE/PERFORMANCE, Diagnostic Trouble Code (DTC) Detecting Criteria.>
P0182	Fuel Temperature Sensor "A" Circuit Low Input	<Ref. to GD(H4DOTC)-80, DTC P0182 FUEL TEMPERATURE SENSOR "A" CIRCUIT LOW INPUT, Diagnostic Trouble Code (DTC) Detecting Criteria.>
P0183	Fuel Temperature Sensor "A" Circuit High Input	<Ref. to GD(H4DOTC)-82, DTC P0183 FUEL TEMPERATURE SENSOR "A" CIRCUIT HIGH INPUT, Diagnostic Trouble Code (DTC) Detecting Criteria.>

List of Diagnostic Trouble Code (DTC)

GENERAL DESCRIPTION

DTC	Description	Index
P0222	Throttle/pedal Position Sensor/switch "B" Circuit Low	<Ref. to GD(H4DOTC)-84, DTC P0222 THROTTLE/PEDAL POSITION SENSOR/SWITCH "B" CIRCUIT LOW, Diagnostic Trouble Code (DTC) Detecting Criteria.>
P0223	Throttle/pedal Position Sensor/switch "B" Circuit High	<Ref. to GD(H4DOTC)-85, DTC P0223 THROTTLE/PEDAL POSITION SENSOR/SWITCH "B" CIRCUIT HIGH, Diagnostic Trouble Code (DTC) Detecting Criteria.>
P0230	Fuel Pump Primary Circuit	<Ref. to GD(H4DOTC)-87, DTC P0230 FUEL PUMP PRIMARY CIRCUIT, Diagnostic Trouble Code (DTC) Detecting Criteria.>
P0244	Turbo/Super Charger Wastegate Solenoid "A" Range/Performance	<Ref. to GD(H4DOTC)-89, DTC P0244 TURBO/SUPER CHARGER WASTEGATE SOLENOID "A" RANGE/PERFORMANCE, Diagnostic Trouble Code (DTC) Detecting Criteria.>
P0245	Turbo/Super Charger Wastegate Solenoid "A" Low	<Ref. to GD(H4DOTC)-91, DTC P0245 TURBO/SUPER CHARGER WASTEGATE SOLENOID "A" LOW, Diagnostic Trouble Code (DTC) Detecting Criteria.>
P0246	Turbo/Super Charger Wastegate Solenoid "A" High	<Ref. to GD(H4DOTC)-93, DTC P0246 TURBO/SUPER CHARGER WASTEGATE SOLENOID "A" HIGH, Diagnostic Trouble Code (DTC) Detecting Criteria.>
P0301	Cylinder 1 Misfire Detected	<Ref. to GD(H4DOTC)-95, DTC P0301 CYLINDER 1 MISFIRE DETECTED, Diagnostic Trouble Code (DTC) Detecting Criteria.>
P0302	Cylinder 2 Misfire Detected	<Ref. to GD(H4DOTC)-100, DTC P0302 CYLINDER 2 MISFIRE DETECTED, Diagnostic Trouble Code (DTC) Detecting Criteria.>
P0303	Cylinder 3 Misfire Detected	<Ref. to GD(H4DOTC)-100, DTC P0303 CYLINDER 3 MISFIRE DETECTED, Diagnostic Trouble Code (DTC) Detecting Criteria.>
P0304	Cylinder 4 Misfire Detected	<Ref. to GD(H4DOTC)-100, DTC P0304 CYLINDER 4 MISFIRE DETECTED, Diagnostic Trouble Code (DTC) Detecting Criteria.>
P0327	Knock Sensor 1 Circuit Low Input (Bank 1 or Single Sensor)	<Ref. to GD(H4DOTC)-101, DTC P0327 KNOCK SENSOR 1 CIRCUIT LOW INPUT (BANK 1 OR SINGLE SENSOR), Diagnostic Trouble Code (DTC) Detecting Criteria.>
P0328	Knock Sensor 1 Circuit High Input (Bank 1 or Single Sensor)	<Ref. to GD(H4DOTC)-103, DTC P0328 KNOCK SENSOR 1 CIRCUIT HIGH INPUT (BANK 1 OR SINGLE SENSOR), Diagnostic Trouble Code (DTC) Detecting Criteria.>
P0335	Crankshaft Position Sensor "A" Circuit	<Ref. to GD(H4DOTC)-105, DTC P0335 CRANKSHAFT POSITION SENSOR "A" CIRCUIT, Diagnostic Trouble Code (DTC) Detecting Criteria.>
P0336	Crankshaft Position Sensor "A" Circuit Range/Performance	<Ref. to GD(H4DOTC)-107, DTC P0336 CRANKSHAFT POSITION SENSOR "A" CIRCUIT RANGE/PERFORMANCE, Diagnostic Trouble Code (DTC) Detecting Criteria.>
P0340	Camshaft Position Sensor "A" Circuit (Bank 1 or Single Sensor)	<Ref. to GD(H4DOTC)-109, DTC P0340 CAMSHAFT POSITION SENSOR "A" CIRCUIT (BANK 1 OR SINGLE SENSOR), Diagnostic Trouble Code (DTC) Detecting Criteria.>
P0345	Camshaft Position Sensor "A" Circuit (Bank 2)	<Ref. to GD(H4DOTC)-110, DTC P0345 CAMSHAFT POSITION SENSOR "A" CIRCUIT (BANK 2), Diagnostic Trouble Code (DTC) Detecting Criteria.>
P0410	Secondary Air Injection System	<Ref. to GD(H4DOTC)-111, DTC P0410 SECONDARY AIR INJECTION SYSTEM, Diagnostic Trouble Code (DTC) Detecting Criteria.>
P0411	Secondary Air Injection System Incorrect Flow Detected	<Ref. to GD(H4DOTC)-115, DTC P0411 SECONDARY AIR INJECTION SYSTEM INCORRECT FLOW DETECTED, Diagnostic Trouble Code (DTC) Detecting Criteria.>
P0413	Secondary Air Injection System Switching Valve "A" Circuit Open	<Ref. to GD(H4DOTC)-116, DTC P0413 SECONDARY AIR INJECTION SYSTEM SWITCHING VALVE "A" CIRCUIT OPEN, Diagnostic Trouble Code (DTC) Detecting Criteria.>
P0414	Secondary Air Injection System Switching Valve "A" Circuit Shorted	<Ref. to GD(H4DOTC)-117, DTC P0414 SECONDARY AIR INJECTION SYSTEM SWITCHING VALVE "A" CIRCUIT SHORTED, Diagnostic Trouble Code (DTC) Detecting Criteria.>
P0416	Secondary Air Injection System Switching Valve "B" Circuit Open	<Ref. to GD(H4DOTC)-118, DTC P0416 SECONDARY AIR INJECTION SYSTEM SWITCHING VALVE "B" CIRCUIT OPEN, Diagnostic Trouble Code (DTC) Detecting Criteria.>

List of Diagnostic Trouble Code (DTC)

GENERAL DESCRIPTION

DTC	Description	Index
P0417	Secondary Air Injection System Switching Valve "B" Circuit Shorted	<Ref. to GD(H4DOTC)-118, DTC P0417 SECONDARY AIR INJECTION SYSTEM SWITCHING VALVE "B" CIRCUIT SHORTED, Diagnostic Trouble Code (DTC) Detecting Criteria.>
P0418	Secondary Air Injection System Control "A" Circuit Open	<Ref. to GD(H4DOTC)-119, DTC P0418 SECONDARY AIR INJECTION SYSTEM CONTROL "A" CIRCUIT OPEN, Diagnostic Trouble Code (DTC) Detecting Criteria.>
P0420	Catalyst System Efficiency Below Threshold (Bank 1)	<Ref. to GD(H4DOTC)-120, DTC P0420 CATALYST SYSTEM EFFICIENCY BELOW THRESHOLD (BANK 1), Diagnostic Trouble Code (DTC) Detecting Criteria.>
P0442	Evaporative Emission Control System Leak Detected (Small Leak)	<Ref. to GD(H4DOTC)-123, DTC P0442 EVAPORATIVE EMISSION CONTROL SYSTEM LEAK DETECTED (SMALL LEAK), Diagnostic Trouble Code (DTC) Detecting Criteria.>
P0447	Evaporative Emission Control System Vent Control Circuit Open	<Ref. to GD(H4DOTC)-139, DTC P0447 EVAPORATIVE EMISSION CONTROL SYSTEM VENT CONTROL CIRCUIT OPEN, Diagnostic Trouble Code (DTC) Detecting Criteria.>
P0448	Evaporative Emission Control System Vent Control Circuit Shorted	<Ref. to GD(H4DOTC)-141, DTC P0448 EVAPORATIVE EMISSION CONTROL SYSTEM VENT CONTROL CIRCUIT SHORTED, Diagnostic Trouble Code (DTC) Detecting Criteria.>
P0451	Evaporative Emission Control System Pressure Sensor Range/Performance	<Ref. to GD(H4DOTC)-143, DTC P0451 EVAPORATIVE EMISSION CONTROL SYSTEM PRESSURE SENSOR RANGE/PERFORMANCE, Diagnostic Trouble Code (DTC) Detecting Criteria.>
P0452	Evaporative Emission Control System Pressure Sensor Low Input	<Ref. to GD(H4DOTC)-145, DTC P0452 EVAPORATIVE EMISSION CONTROL SYSTEM PRESSURE SENSOR LOW INPUT, Diagnostic Trouble Code (DTC) Detecting Criteria.>
P0453	Evaporative Emission Control System Pressure Sensor High Input	<Ref. to GD(H4DOTC)-147, DTC P0453 EVAPORATIVE EMISSION CONTROL SYSTEM PRESSURE SENSOR HIGH INPUT, Diagnostic Trouble Code (DTC) Detecting Criteria.>
P0456	Evaporative Emission Control System Leak Detected (Very Small Leak)	<Ref. to GD(H4DOTC)-148, DTC P0456 EVAPORATIVE EMISSION CONTROL SYSTEM LEAK DETECTED (VERY SMALL LEAK), Diagnostic Trouble Code (DTC) Detecting Criteria.>
P0457	Evaporative Emission Control System Leak Detected (Fuel Cap Loose/Off)	<Ref. to GD(H4DOTC)-148, DTC P0457 EVAPORATIVE EMISSION CONTROL SYSTEM LEAK DETECTED (FUEL CAP LOOSE/OFF), Diagnostic Trouble Code (DTC) Detecting Criteria.>
P0458	Evaporative Emission Control System Purge Control Valve Circuit Low	<Ref. to GD(H4DOTC)-149, DTC P0458 EVAPORATIVE EMISSION CONTROL SYSTEM PURGE CONTROL VALVE CIRCUIT LOW, Diagnostic Trouble Code (DTC) Detecting Criteria.>
P0459	Evaporative Emission Control System Purge Control Valve Circuit High	<Ref. to GD(H4DOTC)-151, DTC P0459 EVAPORATIVE EMISSION CONTROL SYSTEM PURGE CONTROL VALVE CIRCUIT HIGH, Diagnostic Trouble Code (DTC) Detecting Criteria.>
P0461	Fuel Level Sensor Circuit Range/Performance	<Ref. to GD(H4DOTC)-153, DTC P0461 FUEL LEVEL SENSOR CIRCUIT RANGE/PERFORMANCE, Diagnostic Trouble Code (DTC) Detecting Criteria.>
P0462	Fuel Level Sensor Circuit Low Input	<Ref. to GD(H4DOTC)-155, DTC P0462 FUEL LEVEL SENSOR CIRCUIT LOW INPUT, Diagnostic Trouble Code (DTC) Detecting Criteria.>
P0463	Fuel Level Sensor Circuit High Input	<Ref. to GD(H4DOTC)-157, DTC P0463 FUEL LEVEL SENSOR CIRCUIT HIGH INPUT, Diagnostic Trouble Code (DTC) Detecting Criteria.>
P0464	Fuel Level Sensor Circuit Intermittent	<Ref. to GD(H4DOTC)-158, DTC P0464 FUEL LEVEL SENSOR CIRCUIT INTERMITTENT, Diagnostic Trouble Code (DTC) Detecting Criteria.>
P0483	Cooling Fan Rationality Check	<Ref. to GD(H4DOTC)-161, DTC P0483 COOLING FAN RATIONALITY CHECK, Diagnostic Trouble Code (DTC) Detecting Criteria.>
P0502	Vehicle Speed Sensor Circuit Low Input	<Ref. to GD(H4DOTC)-162, DTC P0502 VEHICLE SPEED SENSOR CIRCUIT LOW INPUT, Diagnostic Trouble Code (DTC) Detecting Criteria.>
P0503	Vehicle Speed Sensor Intermittent/Erratic/High	<Ref. to GD(H4DOTC)-163, DTC P0503 VEHICLE SPEED SENSOR INTERMITTENT/ERRATIC/HIGH, Diagnostic Trouble Code (DTC) Detecting Criteria.>

List of Diagnostic Trouble Code (DTC)

GENERAL DESCRIPTION

DTC	Description	Index
P0506	Idle Control System RPM Lower Than Expected	<Ref. to GD(H4DOTC)-165, DTC P0506 IDLE AIR CONTROL SYSTEM RPM LOWER THAN EXPECTED, Diagnostic Trouble Code (DTC) Detecting Criteria.>
P0507	Idle Control System RPM Higher Than Expected	<Ref. to GD(H4DOTC)-167, DTC P0507 IDLE AIR CONTROL SYSTEM RPM HIGHER THAN EXPECTED, Diagnostic Trouble Code (DTC) Detecting Criteria.>
P0512	Starter Request Circuit	<Ref. to GD(H4DOTC)-169, DTC P0512 STARTER REQUEST CIRCUIT, Diagnostic Trouble Code (DTC) Detecting Criteria.>
P0513	Incorrect Immobilizer Key	<Ref. to GD(H4DOTC)-170, DTC P0513 INCORRECT IMMOBILIZER KEY, Diagnostic Trouble Code (DTC) Detecting Criteria.>
P0519	Idle Control System Malfunction (Fail-Safe)	<Ref. to GD(H4DOTC)-171, DTC P0519 IDLE CONTROL SYSTEM MALFUNCTION (FAIL-SAFE), Diagnostic Trouble Code (DTC) Detecting Criteria.>
P0600	Serial Communication Link	<Ref. to GD(H4DOTC)-172, DTC P0600 SERIAL COMMUNICATION LINK, Diagnostic Trouble Code (DTC) Detecting Criteria.>
P0604	Internal Control Module Random Access Memory (RAM) Error	<Ref. to GD(H4DOTC)-173, DTC P0604 INTERNAL CONTROL MODULE RANDOM ACCESS MEMORY (RAM) ERROR, Diagnostic Trouble Code (DTC) Detecting Criteria.>
P0605	Internal Control Module Read Only Memory (ROM) Error	<Ref. to GD(H4DOTC)-174, DTC P0605 INTERNAL CONTROL MODULE READ ONLY MEMORY (ROM) ERROR, Diagnostic Trouble Code (DTC) Detecting Criteria.>
P0607	Control Module Performance	<Ref. to GD(H4DOTC)-175, DTC P0607 CONTROL MODULE PERFORMANCE, Diagnostic Trouble Code (DTC) Detecting Criteria.>
P0638	Throttle Actuator Control Range/Performance (Bank 1)	<Ref. to GD(H4DOTC)-177, DTC P0638 THROTTLE ACTUATOR CONTROL RANGE/PERFORMANCE (BANK 1), Diagnostic Trouble Code (DTC) Detecting Criteria.>
P0691	Cooling Fan 1 Control Circuit Low	<Ref. to GD(H4DOTC)-179, DTC P0691 COOLING FAN 1 CONTROL CIRCUIT LOW, Diagnostic Trouble Code (DTC) Detecting Criteria.>
P0692	Cooling Fan 1 Control Circuit High	<Ref. to GD(H4DOTC)-180, DTC P0692 COOLING FAN 1 CONTROL CIRCUIT HIGH, Diagnostic Trouble Code (DTC) Detecting Criteria.>
P0700	Transmission Control System (MIL Request)	<Ref. to GD(H4DOTC)-181, DTC P0700 TRANSMISSION CONTROL SYSTEM (MIL REQUEST), Diagnostic Trouble Code (DTC) Detecting Criteria.>
P0851	Neutral Switch Input Circuit Low (AT Model)	<Ref. to GD(H4DOTC)-182, DTC P0851 NEUTRAL SWITCH INPUT CIRCUIT LOW (AT MODEL), Diagnostic Trouble Code (DTC) Detecting Criteria.>
P0851	Neutral Switch Input Circuit Low (MT Model)	<Ref. to GD(H4DOTC)-183, DTC P0851 NEUTRAL SWITCH INPUT CIRCUIT LOW (MT MODEL), Diagnostic Trouble Code (DTC) Detecting Criteria.>
P0852	Neutral Switch Input Circuit High (AT Model)	<Ref. to GD(H4DOTC)-184, DTC P0852 NEUTRAL SWITCH INPUT CIRCUIT HIGH (AT MODEL), Diagnostic Trouble Code (DTC) Detecting Criteria.>
P0852	Neutral Switch Input Circuit High (MT Model)	<Ref. to GD(H4DOTC)-185, DTC P0852 NEUTRAL SWITCH INPUT CIRCUIT HIGH (MT MODEL), Diagnostic Trouble Code (DTC) Detecting Criteria.>
P1152	O ₂ Sensor Circuit Range/Performance (Low) (Bank 1 Sensor 1)	<Ref. to GD(H4DOTC)-186, DTC P1152 O ₂ SENSOR CIRCUIT RANGE/PERFORMANCE (LOW) (BANK1 SENSOR1), Diagnostic Trouble Code (DTC) Detecting Criteria.>
P1153	O ₂ Sensor Circuit Range/Performance (High) (Bank 1 Sensor 1)	<Ref. to GD(H4DOTC)-188, DTC P1153 O ₂ SENSOR CIRCUIT RANGE/PERFORMANCE (HIGH) (BANK1 SENSOR1), Diagnostic Trouble Code (DTC) Detecting Criteria.>
P1160	Return Spring Failure	<Ref. to GD(H4DOTC)-190, DTC P1160 RETURN SPRING FAILURE, Diagnostic Trouble Code (DTC) Detecting Criteria.>
P1400	Fuel Tank Pressure Control Solenoid Valve Circuit Low	<Ref. to GD(H4DOTC)-192, DTC P1400 FUEL TANK PRESSURE CONTROL SOLENOID VALVE CIRCUIT LOW, Diagnostic Trouble Code (DTC) Detecting Criteria.>

List of Diagnostic Trouble Code (DTC)

GENERAL DESCRIPTION

DTC	Description	Index
P1410	Secondary Air Injection System Switching Valve Stuck Open	<Ref. to GD(H4DOTC)-194, DTC P1410 SECONDARY AIR INJECTION SYSTEM SWITCHING VALVE STUCK OPEN, Diagnostic Trouble Code (DTC) Detecting Criteria.>
P1418	Secondary Air Injection System Control "A" Circuit Shorted	<Ref. to GD(H4DOTC)-195, DTC P1418 SECONDARY AIR INJECTION SYSTEM CONTROL "A" CIRCUIT SHORTED, Diagnostic Trouble Code (DTC) Detecting Criteria.>
P1420	Fuel Tank Pressure Control Sol. Valve Circuit High	<Ref. to GD(H4DOTC)-196, DTC P1420 FUEL TANK PRESSURE CONTROL SOL. VALVE CIRCUIT HIGH, Diagnostic Trouble Code (DTC) Detecting Criteria.>
P1443	Vent Control Solenoid Valve Function Problem	<Ref. to GD(H4DOTC)-198, DTC P1443 VENT CONTROL SOLENOID VALVE FUNCTION PROBLEM, Diagnostic Trouble Code (DTC) Detecting Criteria.>
P1491	Positive Crankcase Ventilation (Blow-By) Function Problem	<Ref. to GD(H4DOTC)-200, DTC P1491 POSITIVE CRANKCASE VENTILATION (BLOW-BY) FUNCTION PROBLEM, Diagnostic Trouble Code (DTC) Detecting Criteria.>
P1518	Starter Switch Circuit Low Input	<Ref. to GD(H4DOTC)-202, DTC P1518 STARTER SWITCH CIRCUIT LOW INPUT, Diagnostic Trouble Code (DTC) Detecting Criteria.>
P1560	Back-Up Voltage Circuit Malfunction	<Ref. to GD(H4DOTC)-203, DTC P1560 BACK-UP VOLTAGE CIRCUIT MALFUNCTION, Diagnostic Trouble Code (DTC) Detecting Criteria.>
P1570	Antenna	<Ref. to GD(H4DOTC)-204, DTC P1570 ANTENNA, Diagnostic Trouble Code (DTC) Detecting Criteria.>
P1571	Reference Code Incompatibility	<Ref. to GD(H4DOTC)-204, DTC P1571 REFERENCE CODE INCOMPATIBILITY, Diagnostic Trouble Code (DTC) Detecting Criteria.>
P1572	IMM Circuit Failure (Except Antenna Circuit)	<Ref. to GD(H4DOTC)-204, DTC P1572 IMM CIRCUIT FAILURE (EXCEPT ANTENNA CIRCUIT), Diagnostic Trouble Code (DTC) Detecting Criteria.>
P1574	Key Communication Failure	<Ref. to GD(H4DOTC)-204, DTC P1574 KEY COMMUNICATION FAILURE, Diagnostic Trouble Code (DTC) Detecting Criteria.>
P1576	EGI Control Module EEPROM	<Ref. to GD(H4DOTC)-204, DTC P1576 EGI CONTROL MODULE EEPROM, Diagnostic Trouble Code (DTC) Detecting Criteria.>
P1577	IMM Control Module EEPROM	<Ref. to GD(H4DOTC)-204, DTC P1577 IMM CONTROL MODULE EEPROM, Diagnostic Trouble Code (DTC) Detecting Criteria.>
P2004	Intake Manifold Runner Control Stuck Open (Bank 1)	<Ref. to GD(H4DOTC)-205, DTC P2004 INTAKE MANIFOLD RUNNER CONTROL STUCK OPEN (BANK 1), Diagnostic Trouble Code (DTC) Detecting Criteria.>
P2005	Intake Manifold Runner Control Stuck Open (Bank 2)	<Ref. to GD(H4DOTC)-206, DTC P2005 INTAKE MANIFOLD RUNNER CONTROL STUCK OPEN (BANK 2), Diagnostic Trouble Code (DTC) Detecting Criteria.>
P2006	Intake Manifold Runner Control Stuck Closed (Bank 1)	<Ref. to GD(H4DOTC)-207, DTC P2006 INTAKE MANIFOLD RUNNER CONTROL STUCK CLOSED (BANK 1), Diagnostic Trouble Code (DTC) Detecting Criteria.>
P2007	Intake Manifold Runner Control Stuck Closed (Bank 2)	<Ref. to GD(H4DOTC)-208, DTC P2007 INTAKE MANIFOLD RUNNER CONTROL STUCK CLOSED (BANK 2), Diagnostic Trouble Code (DTC) Detecting Criteria.>
P2008	Intake Manifold Runner Control Circuit / Open (Bank 1)	<Ref. to GD(H4DOTC)-209, DTC P2008 INTAKE MANIFOLD RUNNER CONTROL CIRCUIT / OPEN (BANK 1), Diagnostic Trouble Code (DTC) Detecting Criteria.>
P2009	Intake Manifold Runner Control Circuit Low (Bank 1)	<Ref. to GD(H4DOTC)-211, DTC P2009 INTAKE MANIFOLD RUNNER CONTROL CIRCUIT LOW (BANK 1), Diagnostic Trouble Code (DTC) Detecting Criteria.>
P2011	Intake Manifold Runner Control Circuit / Open (Bank 2)	<Ref. to GD(H4DOTC)-213, DTC P2011 INTAKE MANIFOLD RUNNER CONTROL CIRCUIT / OPEN (BANK 2), Diagnostic Trouble Code (DTC) Detecting Criteria.>
P2012	Intake Manifold Runner Control Circuit Low (Bank 2)	<Ref. to GD(H4DOTC)-215, DTC P2012 INTAKE MANIFOLD RUNNER CONTROL CIRCUIT LOW (BANK 2), Diagnostic Trouble Code (DTC) Detecting Criteria.>

List of Diagnostic Trouble Code (DTC)

GENERAL DESCRIPTION

DTC	Description	Index
P2016	Intake Manifold Runner Position Sensor / Switch Circuit Low (Bank 1)	<Ref. to GD(H4DOTC)-217, DTC P2016 INTAKE MANIFOLD RUNNER POSITION SENSOR / SWITCH CIRCUIT LOW (BANK 1), Diagnostic Trouble Code (DTC) Detecting Criteria.>
P2017	Intake Manifold Runner Position Sensor / Switch Circuit High (Bank 1)	<Ref. to GD(H4DOTC)-219, DTC P2017 INTAKE MANIFOLD RUNNER POSITION SENSOR / SWITCH CIRCUIT HIGH (BANK 1), Diagnostic Trouble Code (DTC) Detecting Criteria.>
P2021	Intake Manifold Runner Position Sensor / Switch Circuit Low (Bank 2)	<Ref. to GD(H4DOTC)-221, DTC P2021 INTAKE MANIFOLD RUNNER POSITION SENSOR / SWITCH CIRCUIT LOW (BANK 2), Diagnostic Trouble Code (DTC) Detecting Criteria.>
P2022	Intake Manifold Runner Position Sensor / Switch Circuit High (Bank 2)	<Ref. to GD(H4DOTC)-223, DTC P2022 INTAKE MANIFOLD RUNNER POSITION SENSOR / SWITCH CIRCUIT HIGH (BANK 2), Diagnostic Trouble Code (DTC) Detecting Criteria.>
P2088	OCV Solenoid Valve Signal A Circuit Open (Bank 1)	<Ref. to GD(H4DOTC)-225, DTC P2088 OCV SOLENOID VALVE SIGNAL A CIRCUIT OPEN (BANK 1), Diagnostic Trouble Code (DTC) Detecting Criteria.>
P2089	OCV Solenoid Valve Signal A Circuit Short (Bank 1)	<Ref. to GD(H4DOTC)-227, DTC P2089 OCV SOLENOID VALVE SIGNAL A CIRCUIT SHORT (BANK 1), Diagnostic Trouble Code (DTC) Detecting Criteria.>
P2092	OCV Solenoid Valve Signal A Circuit Open (Bank 2)	<Ref. to GD(H4DOTC)-229, DTC P2092 OCV SOLENOID VALVE SIGNAL A CIRCUIT OPEN (BANK 2), Diagnostic Trouble Code (DTC) Detecting Criteria.>
P2093	Intake Camshaft Position Actuator Control Circuit High (Bank 2)	<Ref. to GD(H4DOTC)-231, DTC P2093 INTAKE CAMSHAFT POSITION ACTUATOR CONTROL CIRCUIT HIGH (BANK 2), Diagnostic Trouble Code (DTC) Detecting Criteria.>
P2096	Post Catalyst Fuel Trim System Too Lean Bank 1	<Ref. to GD(H4DOTC)-233, DTC P2096 POST CATALYST FUEL TRIM SYSTEM TOO LEAN BANK 1, Diagnostic Trouble Code (DTC) Detecting Criteria.>
P2097	Post Catalyst Fuel Trim System Too Rich Bank 1	<Ref. to GD(H4DOTC)-235, DTC P2097 POST CATALYST FUEL TRIM SYSTEM TOO RICH BANK 1, Diagnostic Trouble Code (DTC) Detecting Criteria.>
P2101	Throttle Actuator Control Motor Circuit Range/Performance	<Ref. to GD(H4DOTC)-237, DTC P2101 THROTTLE ACTUATOR CONTROL MOTOR CIRCUIT RANGE/PERFORMANCE, Diagnostic Trouble Code (DTC) Detecting Criteria.>
P2102	Throttle Actuator Control Motor Circuit Low	<Ref. to GD(H4DOTC)-239, DTC P2102 THROTTLE ACTUATOR CONTROL MOTOR CIRCUIT LOW, Diagnostic Trouble Code (DTC) Detecting Criteria.>
P2103	Throttle Actuator Control Motor Circuit High	<Ref. to GD(H4DOTC)-241, DTC P2103 THROTTLE ACTUATOR CONTROL MOTOR CIRCUIT HIGH, Diagnostic Trouble Code (DTC) Detecting Criteria.>
P2109	Throttle/Pedal Position Sensor "A" Minimum Stop Performance	<Ref. to GD(H4DOTC)-243, DTC P2109 THROTTLE/PEDAL POSITION SENSOR A MINIMUM STOP PERFORMANCE, Diagnostic Trouble Code (DTC) Detecting Criteria.>
P2122	Throttle/Pedal Position Sensor/Switch "D" Circuit Low Input	<Ref. to GD(H4DOTC)-244, DTC P2122 THROTTLE/PEDAL POSITION SENSOR/SWITCH "D" CIRCUIT LOW INPUT, Diagnostic Trouble Code (DTC) Detecting Criteria.>
P2123	Throttle/Pedal Position Sensor/Switch "D" Circuit High Input	<Ref. to GD(H4DOTC)-246, DTC P2123 THROTTLE/PEDAL POSITION SENSOR/SWITCH "D" CIRCUIT HIGH INPUT, Diagnostic Trouble Code (DTC) Detecting Criteria.>
P2127	Throttle/Pedal Position Sensor/Switch "E" Circuit Low Input	<Ref. to GD(H4DOTC)-247, DTC P2127 THROTTLE/PEDAL POSITION SENSOR/SWITCH "E" CIRCUIT LOW INPUT, Diagnostic Trouble Code (DTC) Detecting Criteria.>
P2128	Throttle/Pedal Position Sensor/Switch "E" Circuit High Input	<Ref. to GD(H4DOTC)-249, DTC P2128 THROTTLE/PEDAL POSITION SENSOR/SWITCH "E" CIRCUIT HIGH INPUT, Diagnostic Trouble Code (DTC) Detecting Criteria.>
P2135	Throttle/Pedal Position Sensor/Switch "A"/"B" Voltage Correlation	<Ref. to GD(H4DOTC)-250, DTC P2135 THROTTLE/PEDAL POSITION SENSOR/SWITCH "A"/"B" VOLTAGE CORRELATION, Diagnostic Trouble Code (DTC) Detecting Criteria.>

List of Diagnostic Trouble Code (DTC)

GENERAL DESCRIPTION

DTC	Description	Index
P2138	Throttle/Pedal Position Sensor/Switch "D"/"E" Voltage Correlation	<Ref. to GD(H4DOTC)-252, DTC P2138 THROTTLE/PEDAL POSITION SENSOR/SWITCH "D"/"E" VOLTAGE CORRELATION, Diagnostic Trouble Code (DTC) Detecting Criteria.>
P2227	Barometric Pressure Too Low	<Ref. to GD(H4DOTC)-254, DTC P2227 BAROMETRIC PRESSURE TOO LOW, Diagnostic Trouble Code (DTC) Detecting Criteria.>
P2228	Atmospheric Pressure Sensor Circuit Malfunction (Low Input)	<Ref. to GD(H4DOTC)-255, DTC P2228 ATMOSPHERIC PRESSURE SENSOR CIRCUIT MALFUNCTION (LOW INPUT), Diagnostic Trouble Code (DTC) Detecting Criteria.>
P2229	Atmospheric Pressure Sensor Circuit Malfunction (High Input)	<Ref. to GD(H4DOTC)-256, DTC P2229 ATMOSPHERIC PRESSURE SENSOR CIRCUIT MALFUNCTION (HIGH INPUT), Diagnostic Trouble Code (DTC) Detecting Criteria.>
P2431	Secondary Air Injection System Air Flow /Pressure Sensor Circuit Range/Performance	<Ref. to GD(H4DOTC)-257, DTC P2431 SECONDARY AIR INJECTION SYSTEM AIR FLOW / PRESSURE SENSOR CIRCUIT RANGE / PERFORMANCE, Diagnostic Trouble Code (DTC) Detecting Criteria.>
P2432	Secondary Air Injection System Air Flow /Pressure Sensor Circuit Low	<Ref. to GD(H4DOTC)-258, DTC P2432 SECONDARY AIR INJECTION SYSTEM AIR FLOW / PRESSURE SENSOR CIRCUIT LOW, Diagnostic Trouble Code (DTC) Detecting Criteria.>
P2433	Secondary Air Injection System Air Flow /Pressure Sensor Circuit High	<Ref. to GD(H4DOTC)-259, DTC P2433 SECONDARY AIR INJECTION SYSTEM AIR FLOW / PRESSURE SENSOR CIRCUIT HIGH, Diagnostic Trouble Code (DTC) Detecting Criteria.>
P2440	Secondary Air Injection System Switching Valve Stuck Open (Bank 1)	<Ref. to GD(H4DOTC)-260, DTC P2440 SECONDARY AIR INJECTION SYSTEM SWITCHING VALVE STUCK OPEN (BANK1), Diagnostic Trouble Code (DTC) Detecting Criteria.>
P2441	Secondary Air Injection System Switching Valve Stuck Closed (Bank 1)	<Ref. to GD(H4DOTC)-260, DTC P2441 SECONDARY AIR INJECTION SYSTEM SWITCHING VALVE STUCK CLOSED (BANK1), Diagnostic Trouble Code (DTC) Detecting Criteria.>
P2442	Secondary Air Injection System Switching Valve Stuck Open (Bank 2)	<Ref. to GD(H4DOTC)-260, DTC P2442 SECONDARY AIR INJECTION SYSTEM SWITCHING VALVE STUCK OPEN (BANK2), Diagnostic Trouble Code (DTC) Detecting Criteria.>
P2443	Secondary Air Injection System Switching Valve Stuck Closed (Bank 2)	<Ref. to GD(H4DOTC)-260, DTC P2443 SECONDARY AIR INJECTION SYSTEM SWITCHING VALVE STUCK CLOSED (BANK2), Diagnostic Trouble Code (DTC) Detecting Criteria.>
P2444	Secondary Air Injection System Pump Stuck On	<Ref. to GD(H4DOTC)-261, DTC P2444 SECONDARY AIR INJECTION SYSTEM PUMP STUCK ON, Diagnostic Trouble Code (DTC) Detecting Criteria.>

Diagnostic Trouble Code (DTC) Detecting Criteria

GENERAL DESCRIPTION

2. Diagnostic Trouble Code (DTC) Detecting Criteria

A: DTC P0011 INTAKE CAMSHAFT POSITION - TIMING OVER-ADVANCED OR SYSTEM PERFORMANCE (BANK 1)

1. OUTLINE OF DIAGNOSIS

Detect the malfunction of AVCS system.

There are two types of diagnosis; crankshaft and camshaft position diagnosis and slow response diagnosis. Perform one of two according to operation status.

2. COMPONENT DESCRIPTION

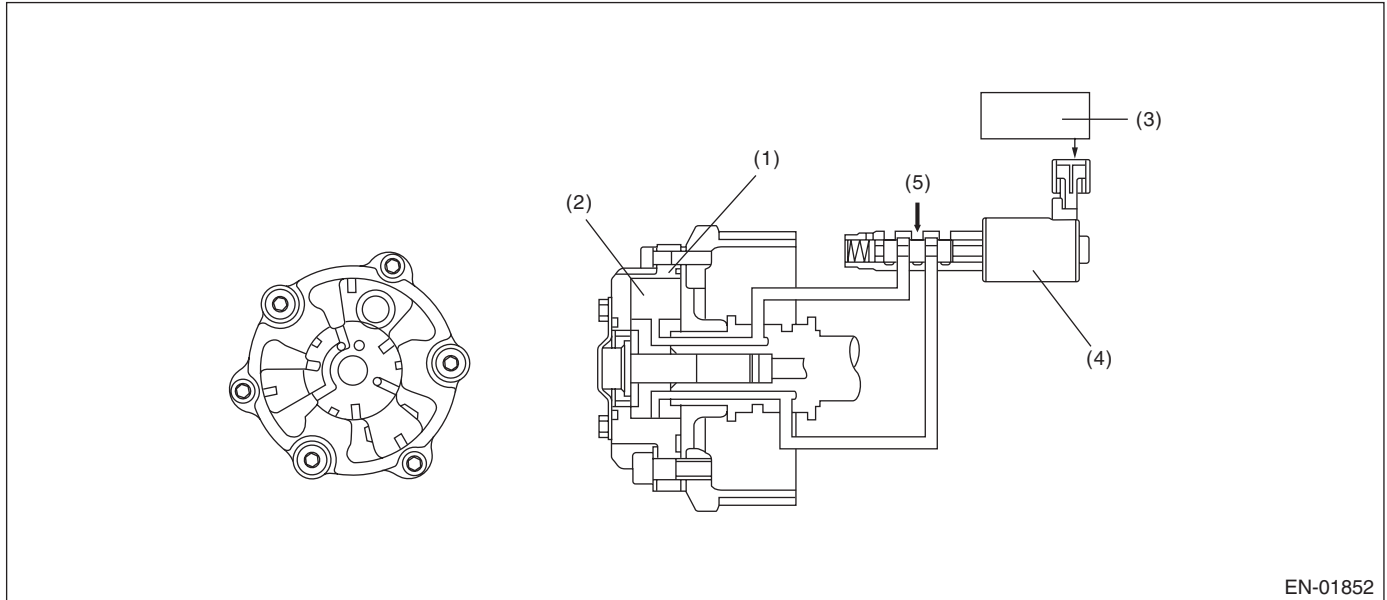

- (1) AVCS timing controller
- (2) Vane
- (3) Engine control module (ECM)
- (4) Oil flow control solenoid valve
- (5) Oil pressure

3. ENABLE CONDITION

(1) Crankshaft and camshaft position diagnosis

Secondary Parameters	Enable Conditions
Battery voltage	≥ 10.9 V
Engine coolant temperature	$> 60^{\circ}\text{C}$ (140°F)
Amount of target timing advance	$= 0^{\circ}\text{CA}$
Engine speed	≥ 500 rpm
AVCS	Not in operation

Diagnostic Trouble Code (DTC) Detecting Criteria

GENERAL DESCRIPTION

(2) Slow response diagnosis

Secondary Parameters	Enable Conditions
All the secondary parameters can be performed.	More than 1 second
Battery voltage	$\geq 10.9 \text{ V}$
Engine coolant temperature	$> 60^{\circ}\text{C}$ (140°F)
Amount of AVCS target timing advance	$\neq 0^{\circ}\text{CA}$
Engine speed	$\geq 1,300 \text{ rpm}$
AVCS	In operation
Variable amount of target timing advance	$< 1.07^{\circ}\text{CA}$

4. GENERAL DRIVING CYCLE

(1) Crankshaft and camshaft position diagnosis

Always perform the diagnosis continuously after starting the engine while the AVCS is not operated.

(2) Slow response diagnosis

Always perform the diagnosis continuously after starting the engine while the AVCS is operated.

5. DIAGNOSTIC METHOD

(1) Crankshaft and camshaft position diagnosis

Judge NG when standard amount of timing advance is outside of normal range, and judge OK when it is within normal range.

Judge NG when the continuous time of completing the malfunction criteria below becomes more than 20 seconds, and judge OK and clear the NG when the continuous time of not completing the malfunction criteria below becomes more than 1 second.

Judgment Value

Malfunction Criteria	Threshold Value
Standard amount of timing advance	$< -13^{\circ}\text{CA}$ or $> 25^{\circ}\text{CA}$

Time Needed for Diagnosis: 20 seconds

Malfunction Indicator Light Illumination: Illuminates when malfunction occurs in 2 continuous driving cycles.

(2) Slow response diagnosis

Accumulate the AVCS deviation amount in positive and negative while AVCS is operated. Judge NG when cumulative value is large at interval of certain time (30 seconds).

• Abnormality Judgment

Judge OK when the malfunction criteria below are completed.

Judgment Value

Malfunction Criteria	Threshold Value
AVCS target position	$\geq 0^{\circ}\text{CA}$
Cumulative value of AVCS positive deviation	$< 8000^{\circ}\text{CA}$ (R bank) $< 8000^{\circ}\text{CA}$ (L bank)
or	
Cumulative value of AVCS negative deviation	$< -8000^{\circ}\text{CA}$ (R bank) $< -8000^{\circ}\text{CA}$ (L bank)

Time Needed for Diagnosis: 30 seconds

Malfunction Indicator Light Illumination: Illuminates when malfunction occurs in 2 continuous driving cycles.

Diagnostic Trouble Code (DTC) Detecting Criteria

GENERAL DESCRIPTION

• Normality Judgment

Judge OK and clear the NG when the malfunction criteria below are completed.

Judgment Value

Malfunction Criteria	Threshold Value
AVCS target position	$\geq 0^{\circ}\text{CA}$
Cumulative value of AVCS positive deviation	$\leq 8000^{\circ}\text{CA}$ (R bank) $\leq 8000^{\circ}\text{CA}$ (L bank)
or	
Cumulative value of AVCS negative deviation	$\geq -8000^{\circ}\text{CA}$ (R bank) $\geq -8000^{\circ}\text{CA}$ (L bank)

6. DTC CLEAR CONDITION

- When the OK idling cycle was completed 40 times in a row
- When "Clear Memory" was performed

7. MALFUNCTION INDICATOR LIGHT CLEAR CONDITION

- When the OK driving cycle was completed 3 times in a row
- When "Clear Memory" was performed

8. FAIL SAFE

None

9. ECM OPERATION AT DTC SETTING

Memorize the freeze frame data. (For test mode \$02)

B: DTC P0016 CRANKSHAFT POSITION - CAMSHAFT POSITION CORRELATION (BANK 1)

NOTE:

For the diagnostic procedure, refer to DTC P0011. <Ref. to GD(H4DOTC)-10, DTC P0011 INTAKE CAMSHAFT POSITION - TIMING OVER-ADVANCED OR SYSTEM PERFORMANCE (BANK 1), Diagnostic Trouble Code (DTC) Detecting Criteria.>

C: DTC P0018 CRANKSHAFT POSITION - CAMSHAFT POSITION CORRELATION (BANK 2)

NOTE:

For the diagnostic procedure, refer to DTC P0011. <Ref. to GD(H4DOTC)-10, DTC P0011 INTAKE CAMSHAFT POSITION - TIMING OVER-ADVANCED OR SYSTEM PERFORMANCE (BANK 1), Diagnostic Trouble Code (DTC) Detecting Criteria.>

D: DTC P0021 INTAKE CAMSHAFT POSITION - TIMING OVER-ADVANCED OR SYSTEM PERFORMANCE (BANK 2)

NOTE:

For the diagnostic procedure, refer to DTC P0011. <Ref. to GD(H4DOTC)-10, DTC P0011 INTAKE CAMSHAFT POSITION - TIMING OVER-ADVANCED OR SYSTEM PERFORMANCE (BANK 1), Diagnostic Trouble Code (DTC) Detecting Criteria.>

E: DTC P0030 HO2S HEATER CONTROL CIRCUIT (BANK 1 SENSOR 1)

1. OUTLINE OF DIAGNOSIS

Detect the malfunction of front oxygen (A/F) sensor heater.

Judge NG when impedance of front oxygen (A/F) sensor is larger than the standard value by referring to the engine condition such as fuel shut-off in deceleration, etc.

2. COMPONENT DESCRIPTION

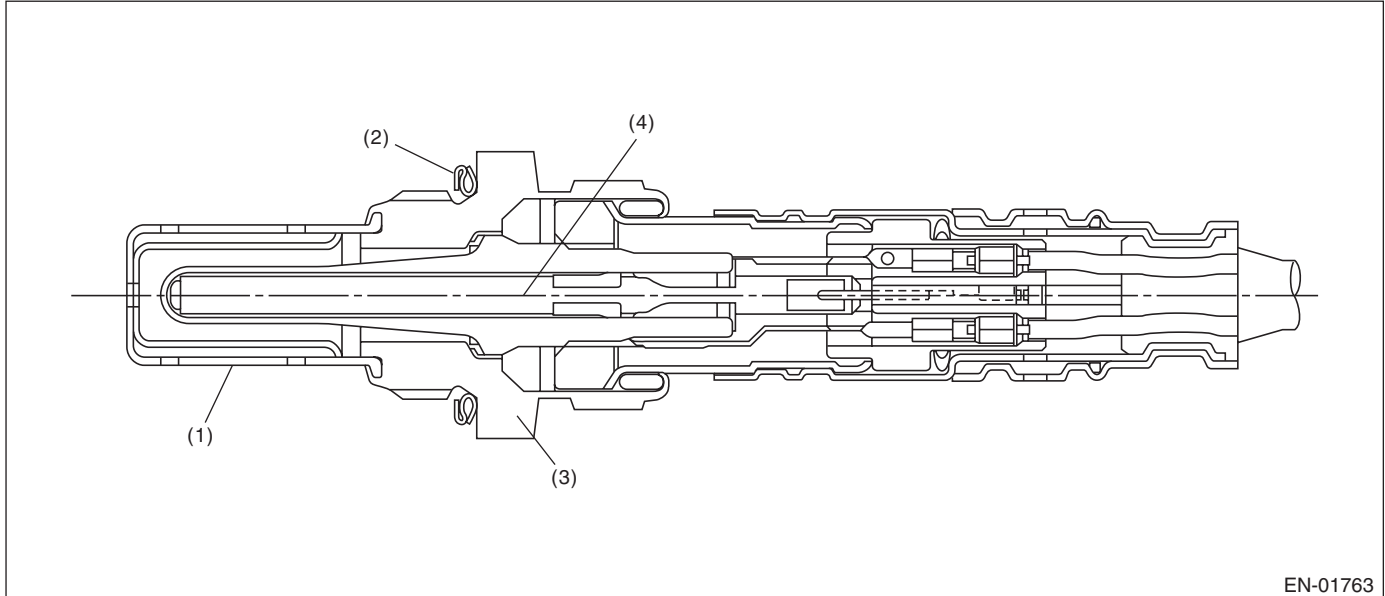

EN-01763

- (1) Protection tube
- (2) Gasket
- (3) Sensor housing
- (4) Ceramic heater

3. ENABLE CONDITION

Secondary Parameters	Enable Conditions
Continuous time which all the following conditions were filled	30 seconds or more
Battery voltage	> 10.9 V
After fuel shut-off	10 seconds or more
Front oxygen (A/F) sensor heater control duty \geq 35%	Experienced
Heater current	Permit

4. GENERAL DRIVING CYCLE

Perform diagnosis continuously in 30 seconds after starting engine.

5. DIAGNOSTIC METHOD

Judge NG when the continuous time of completing the malfunction criteria below becomes more than the time needed for diagnosis (10 seconds). Judge OK and clear NG when the continuous time of not completing the malfunction criteria below becomes more than the time needed for diagnosis (10 seconds).

Judgment Value

Malfunction Criteria	Threshold Value
Impedance of front oxygen (A/F) sensor	> 50 Ω

Time Needed for Diagnosis: 10 seconds

Diagnostic Trouble Code (DTC) Detecting Criteria

GENERAL DESCRIPTION

Malfunction Indicator Light Illumination: Illuminates when malfunction occurs in 2 continuous driving cycles.

6. DTC CLEAR CONDITION

- When the OK idling cycle was completed 40 times in a row
- When "Clear Memory" was performed

7. MALFUNCTION INDICATOR LIGHT CLEAR CONDITION

- When the OK driving cycle was completed 3 times in a row
- When "Clear Memory" was performed

8. FAIL SAFE

- Front oxygen (A/F) sensor main learning correction: Not allowed to calculate
- Correction when re-starting at high temperature: Normally minimum value 0.3 → 0
- Purge control: Not allowed to purge

9. ECM OPERATION AT DTC SETTING

Memorize the freeze frame data. (For test mode \$02)

F: DTC P0031 HO2S HEATER CONTROL CIRCUIT LOW (BANK 1 SENSOR 1)

1. OUTLINE OF DIAGNOSIS

Detect the open or short circuit of front oxygen (A/F) sensor heater.

The front oxygen (A/F) sensor heater conducts the duty control. The output terminal voltage at ON becomes 0 V, and the output terminal voltage at OFF becomes battery voltage.

Judge NG when the terminal voltage remains to be Low.

2. COMPONENT DESCRIPTION

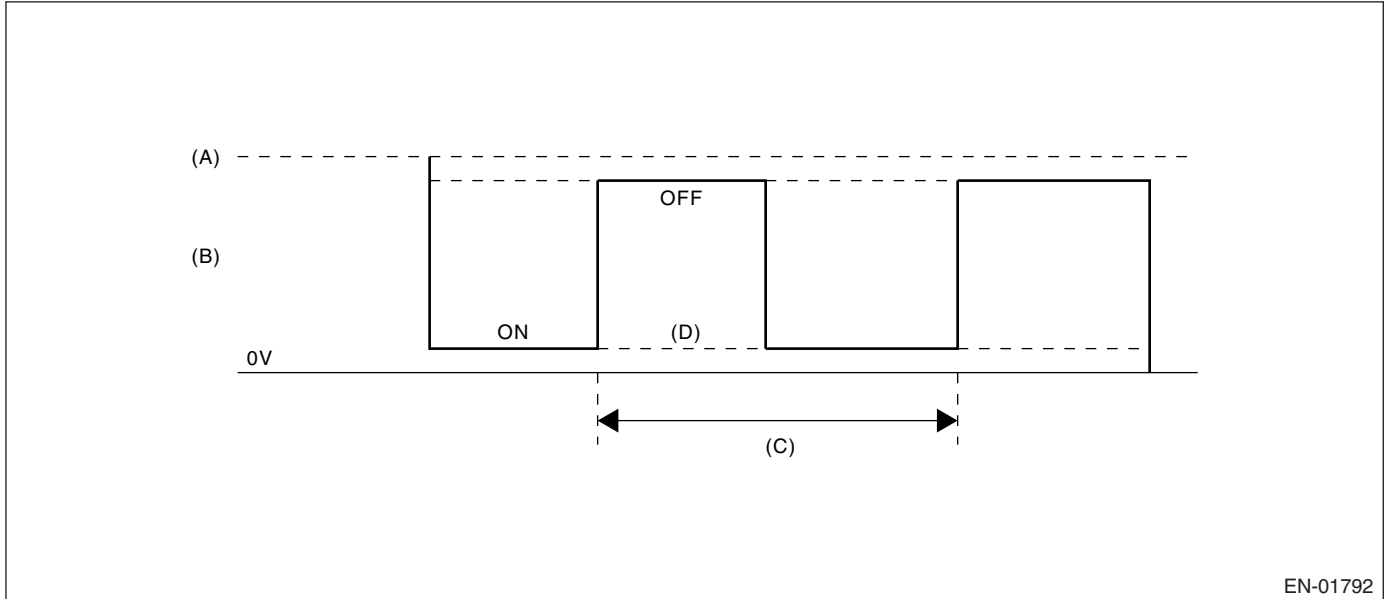

EN-01792

- | | |
|---|------------------------------------|
| (A) Battery voltage | (C) 128 milliseconds |
| (B) Front oxygen (A/F) sensor heater output voltage | (D) Low abnormality output voltage |

3. ENABLE CONDITION

Secondary Parameters	Enable Conditions
Battery voltage	≥ 10.9 V

4. GENERAL DRIVING CYCLE

Always perform diagnosis continuously.

5. DIAGNOSTIC METHOD

• Abnormality Judgment

Judge NG when the continuous time of completing the malfunction criteria below becomes more than 1 second (8 cycles).

Judgment Value

Malfunction Criteria	Threshold Value
Output voltage level	Low
Front oxygen (A/F) sensor heater control duty	< 87.5%

Time Needed for Diagnosis: 1 second

Malfunction Indicator Light Illumination: Illuminates as soon as malfunction occurs.

Diagnostic Trouble Code (DTC) Detecting Criteria

GENERAL DESCRIPTION

• Normality Judgment

Judge OK and clear the NG when all the malfunction criteria below are completed.

Judgment Value

Malfunction Criteria	Threshold Value
Output voltage level	High

6. DTC CLEAR CONDITION

- When the OK idling cycle was completed 40 times in a row
- When “Clear Memory” was performed

7. MALFUNCTION INDICATOR LIGHT CLEAR CONDITION

- When the OK driving cycle was completed 3 times in a row
- When “Clear Memory” was performed

8. FAIL SAFE

- Front oxygen (A/F) sensor activation judgment: Front oxygen (A/F) sensor full activation is not complete, or front oxygen (A/F) sensor half activation is not complete.
- Front oxygen sensor main learning correction: Not allowed to calculate.
- Compensation when starting the engine at high temperature: Make the MIN value to be 0 from 0.3 normally.
- Purge control: Not allowed to purge.

9. ECM OPERATION AT DTC SETTING

Memorize the freeze frame data. (For test mode \$02)

G: DTC P0032 HO2S HEATER CONTROL CIRCUIT HIGH (BANK 1 SENSOR 1)

1. OUTLINE OF DIAGNOSIS

Detect the open or short circuit of front oxygen (A/F) sensor heater.

The front oxygen (A/F) sensor heater conducts the duty control. The output terminal voltage at ON becomes 0 V, and the output terminal voltage at OFF becomes battery voltage.

Judge NG when the terminal voltage remains to be High.

2. COMPONENT DESCRIPTION

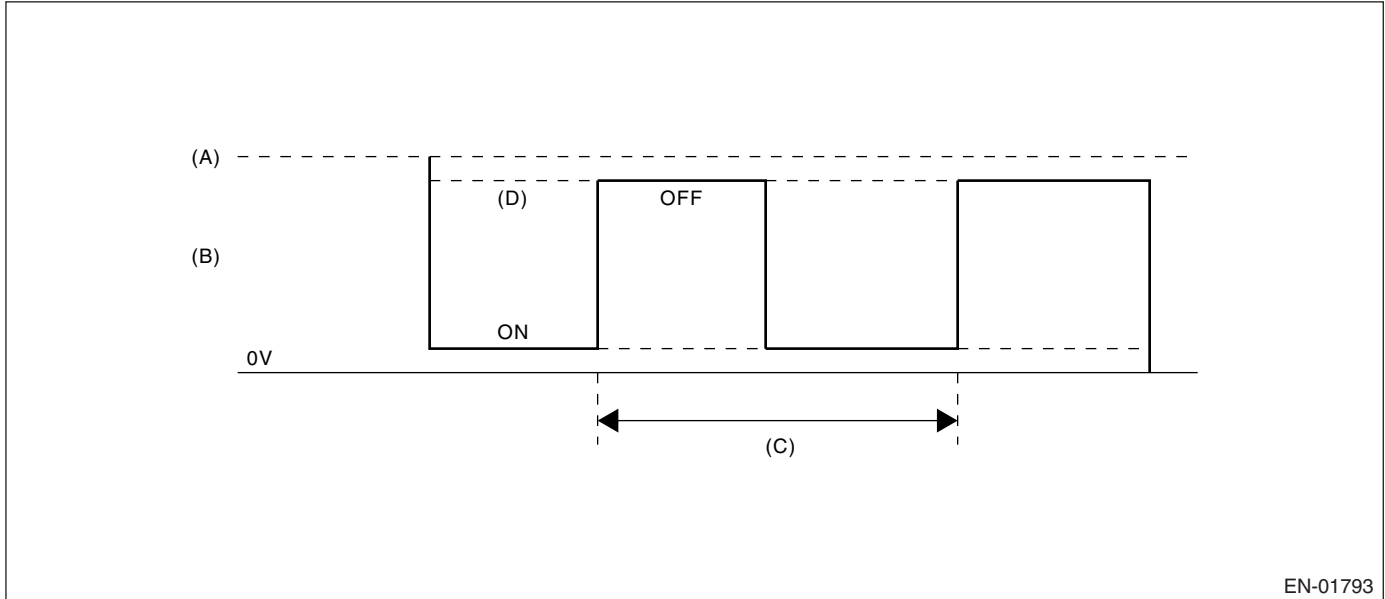

EN-01793

- | | |
|---|-------------------------------------|
| (A) Battery voltage | (C) 128 milliseconds |
| (B) Front oxygen (A/F) sensor heater output voltage | (D) High abnormality output voltage |

3. ENABLE CONDITION

Secondary Parameters	Enable Conditions
Battery voltage	$\geq 10.9 \text{ V}$

4. GENERAL DRIVING CYCLE

Always perform diagnosis continuously.

5. DIAGNOSTIC METHOD

• Abnormality Judgment

Judge NG when the continuous time of completing the malfunction criteria below becomes 1 second (8 cycles).

Judgment Value

Malfunction Criteria	Threshold Value
Output voltage level	High
Front oxygen (A/F) sensor heater control duty	$\geq 12.5\%$

Time Needed for Diagnosis: 1 second

Malfunction Indicator Light Illumination: Illuminates as soon as malfunction occurs.

Diagnostic Trouble Code (DTC) Detecting Criteria

GENERAL DESCRIPTION

• Normality Judgment

Judge OK and clear the NG when all the malfunction criteria below are completed.

Judgment Value

Malfunction Criteria	Threshold Value
Output voltage level	Low

6. DTC CLEAR CONDITION

- When the OK idling cycle was completed 40 times in a row
- When "Clear Memory" was performed

7. MALFUNCTION INDICATOR LIGHT CLEAR CONDITION

- When the OK driving cycle was completed 3 times in a row
- When "Clear Memory" was performed

8. FAIL SAFE

- Front oxygen (A/F) sensor activation judgment: Front oxygen (A/F) sensor full activation is not complete, or front oxygen (A/F) sensor half activation is not complete.
- Front oxygen sensor main learning correction: Not allowed to calculate.
- Compensation when starting the engine at high temperature: Make the MIN value to be 0 from 0.3 normally.
- Purge control: Not allowed to purge.

9. ECM OPERATION AT DTC SETTING

Memorize the freeze frame data. (For test mode \$02)

Diagnostic Trouble Code (DTC) Detecting Criteria

GENERAL DESCRIPTION

H: DTC P0037 HO2S HEATER CONTROL CIRCUIT LOW (BANK 1 SENSOR 2)

1. OUTLINE OF DIAGNOSIS

Detect open or short circuit of rear oxygen sensor heater.

Rear oxygen sensor heater conducted the duty control, and the output terminal voltage at ON is 0 V and the output terminal voltage at OFF is the battery voltage.

Judge NG when the terminal voltage remains to be Low.

2. COMPONENT DESCRIPTION

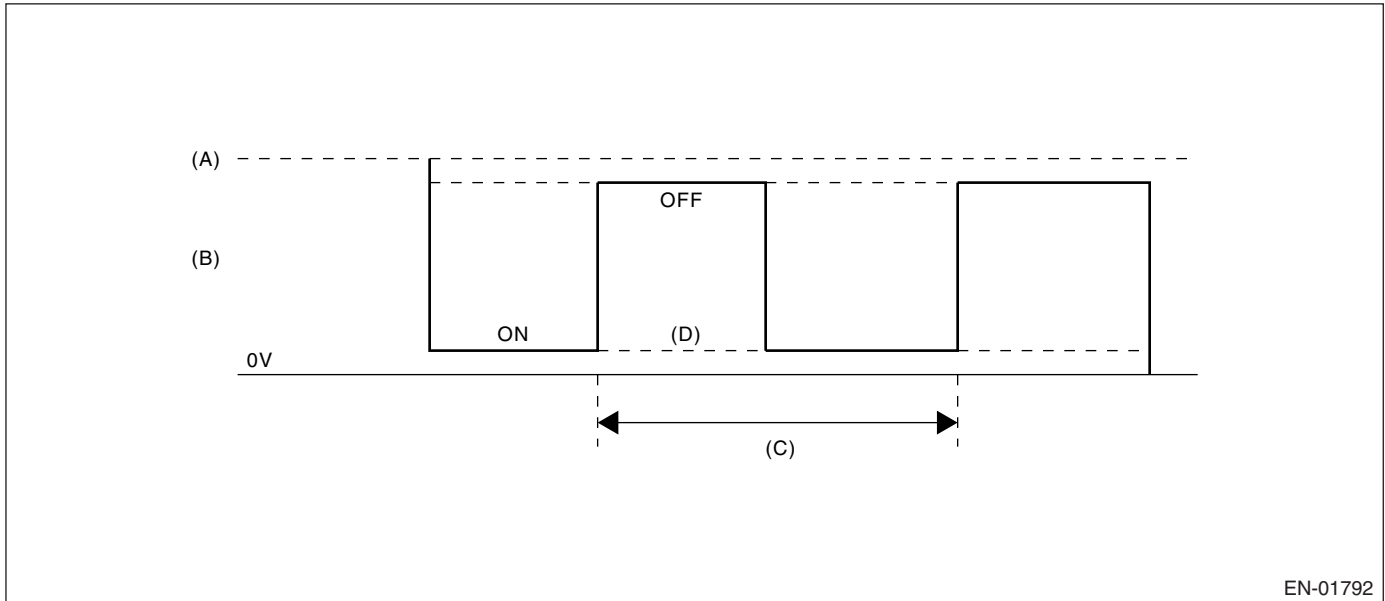

EN-01792

- | | |
|---|-------------------------------|
| (A) Battery voltage | (C) 256 milliseconds (cycles) |
| (B) Oxygen sensor heater output voltage | (D) Low malfunction |

3. ENABLE CONDITION

Secondary Parameters	Enable Conditions
Battery voltage	> 10.9 V

4. GENERAL DRIVING CYCLE

Perform the diagnosis continuously after engine starting.

5. DIAGNOSTIC METHOD

• Abnormality Judgment

Judge NG when the continuous time of completing all the malfunction criteria below becomes more than 2,560 millisecond (10 cycles).

Judgment Value

Malfunction Criteria	Threshold Value
Output voltage level	Low
Rear oxygen sensor heater control duty	< 75%

Time Needed for Diagnosis: 2.56 seconds

Malfunction Indicator Light Illumination: Illuminates when malfunction occurs in 2 continuous driving cycles.

Diagnostic Trouble Code (DTC) Detecting Criteria

GENERAL DESCRIPTION

• Normality Judgment

Judge OK and clear the NG when all the malfunction criteria below are completed.

Judgment Value

Malfunction Criteria	Threshold Value
Output voltage level	High

6. DTC CLEAR CONDITION

- When the OK idling cycle was completed 40 times in a row
- When "Clear Memory" was performed

7. MALFUNCTION INDICATOR LIGHT CLEAR CONDITION

- When the OK driving cycle was completed 3 times in a row
- When "Clear Memory" was performed

8. FAIL SAFE

Sub feedback control: Not allowed

9. ECM OPERATION AT DTC SETTING

Memorize the freeze frame data. (For test mode \$02)

Diagnostic Trouble Code (DTC) Detecting Criteria

GENERAL DESCRIPTION

I: DTC P0038 HO2S HEATER CONTROL CIRCUIT HIGH (BANK 1 SENSOR 2)

1. OUTLINE OF DIAGNOSIS

Detect open or short circuit of rear oxygen heater.

Rear oxygen heater conducted the duty control, and the output terminal voltage at ON is 0 V and the output terminal voltage at OFF is the battery voltage.

Judge NG when the terminal voltage remains to be High.

2. COMPONENT DESCRIPTION

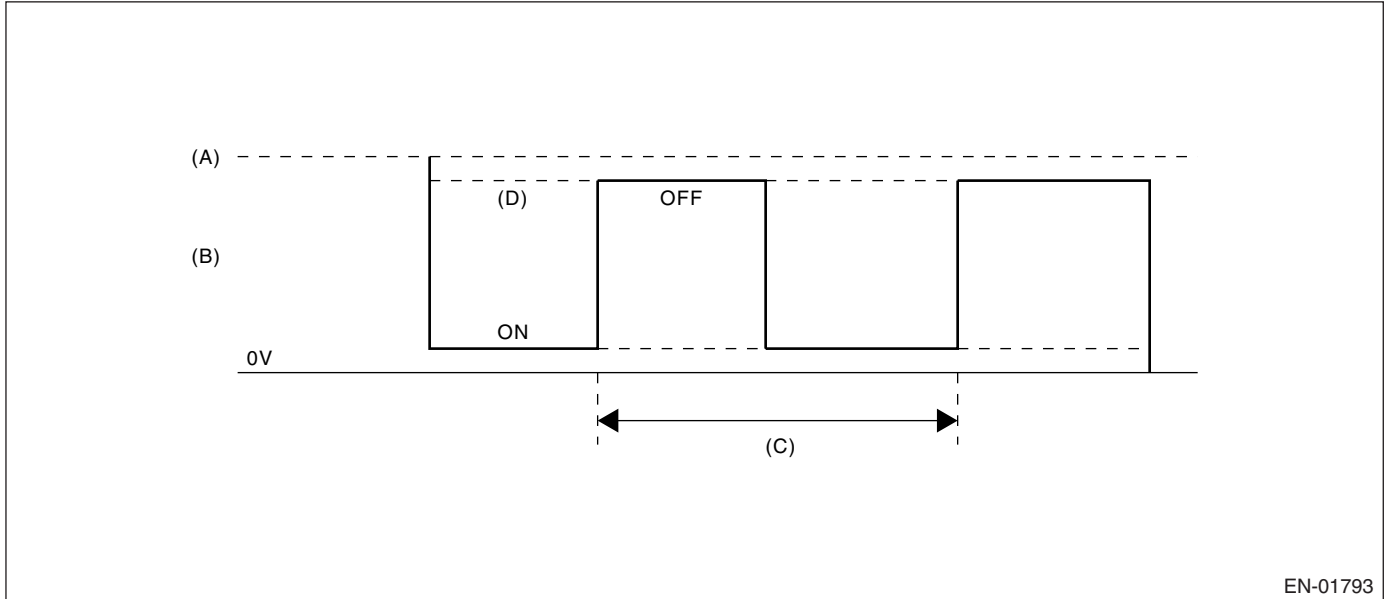

EN-01793

- | | |
|---|-------------------------------|
| (A) Battery voltage | (C) 256 milliseconds (cycles) |
| (B) Oxygen sensor heater output voltage | (D) High malfunction |

3. ENABLE CONDITION

Secondary Parameters	Enable Conditions
Battery voltage	> 10.9 V

4. GENERAL DRIVING CYCLE

Perform the diagnosis continuously after engine starting.

5. DIAGNOSTIC METHOD

• Abnormality Judgment

Judge NG when the continuous time of completing all the malfunction criteria below becomes more than 2,560 milliseconds (10 cycles).

Judgment Value

Malfunction Criteria	Threshold Value
Output voltage level	High
Rear oxygen sensor heater control duty	≥ 25%

Time Needed for Diagnosis: 2.56 seconds

Malfunction Indicator Light Illumination: Illuminates when malfunction occurs in 2 continuous driving cycles.

Diagnostic Trouble Code (DTC) Detecting Criteria

GENERAL DESCRIPTION

• Normality Judgment

Judge OK and clear the NG when all the malfunction criteria below are completed.

Judgment Value

Malfunction Criteria	Threshold Value
Output voltage level	Low

6. DTC CLEAR CONDITION

- When the OK idling cycle was completed 40 times in a row
- When "Clear Memory" was performed

7. MALFUNCTION INDICATOR LIGHT CLEAR CONDITION

- When the OK driving cycle was completed 3 times in a row
- When "Clear Memory" was performed

8. FAIL SAFE

Sub feedback control: Not allowed

9. ECM OPERATION AT DTC SETTING

Memorize the freeze frame data. (For test mode \$02)

Diagnostic Trouble Code (DTC) Detecting Criteria

GENERAL DESCRIPTION

J: DTC P0068 MANIFOLD PRESSURE SENSOR RANGE/PERFORMANCE

1. OUTLINE OF DIAGNOSIS

Detect the malfunction of intake manifold pressure sensor output property. Judge NG when the intake air pressure AD value is Low whereas it seemed to be High from the viewpoint of engine condition, or when it is High whereas it seemed to be Low from the engine condition.

2. COMPONENT DESCRIPTION

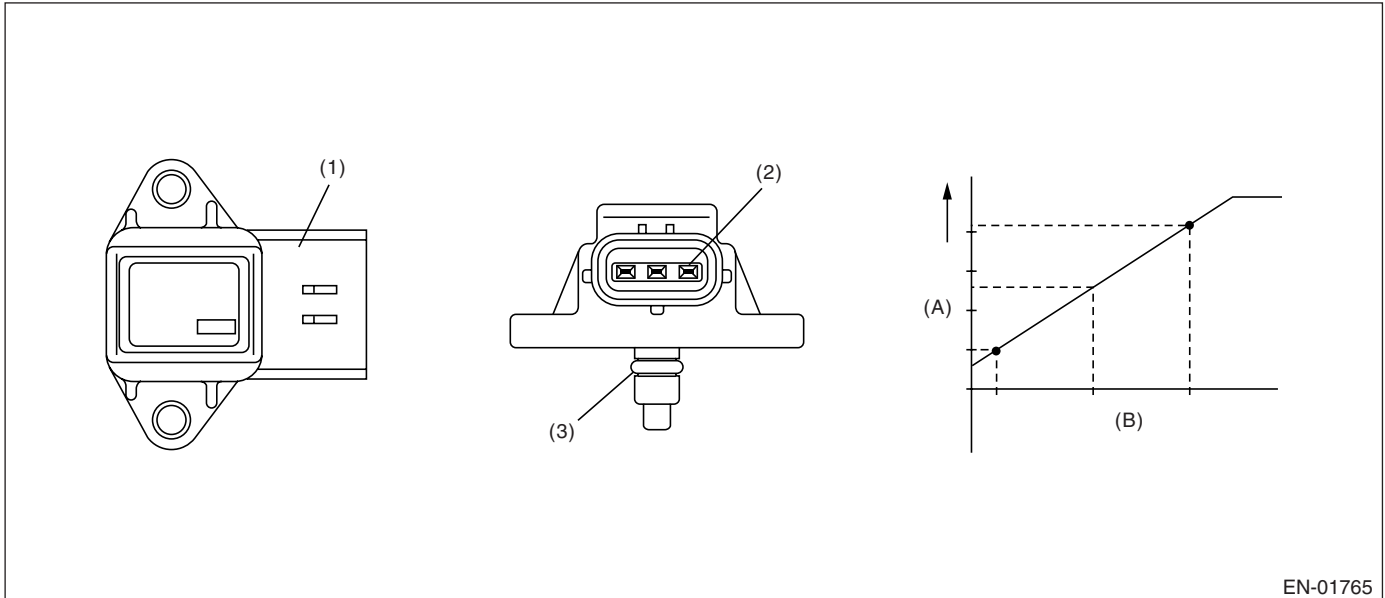

- (1) Connector
- (2) Terminal
- (3) O-ring

- (A) Output voltage
- (B) Absolute pressure

3. ENABLE CONDITION

Secondary Parameters	Enable Conditions
Engine coolant temperature	$\geq 70^{\circ}\text{C}$ (158°F)

4. GENERAL DRIVING CYCLE

Perform the diagnosis continuously after idling.

Diagnostic Trouble Code (DTC) Detecting Criteria

GENERAL DESCRIPTION

5. DIAGNOSTIC METHOD

• Abnormality Judgment

Judge NG when either Low side or High side becomes NG. Judge NG when the continuous time of completing the malfunction criteria below becomes more than 3 seconds.

Judgment Value

Malfunction Criteria	Threshold Value
Low side	
Engine speed	< 2,500 rpm
Throttle position	≥ 10°
Intake air amount per engine 0.5 rev.	> 1.356 g/rev
Output voltage	< 1.0 V
High side	
Engine speed	600 ←→ 900 rpm
Throttle position	< 1.3°
Intake air amount per engine 0.5 rev.	> 0.4 g/rev
Output voltage	≥ 2.36 V

Time Needed for Diagnosis: 3 seconds

Malfunction Indicator Light Illumination: Illuminates when malfunction occurs in 2 continuous driving cycles.

• Normality Judgment

Judge OK and clear the NG when both Low side and High side become OK. Judge OK when the malfunction criteria below are completed.

Judgment Value

Malfunction Criteria	Threshold Value
Low side	
Engine speed	< 2,500 rpm
Throttle position	≥ 10°
Output voltage	≥ 1.0 V
High side	
Engine speed	600 ←→ 900 rpm
Throttle position	< 1.3°
Output voltage	< 2.36 V

6. DTC CLEAR CONDITION

- When the OK idling cycle was completed 40 times in a row
- When "Clear Memory" was performed

7. MALFUNCTION INDICATOR LIGHT CLEAR CONDITION

- When the OK driving cycle was completed 3 times in a row
- When "Clear Memory" was performed

8. FAIL SAFE

- Intake manifold pressure sensor process: Estimate the pressure from engine load.
- ISC feedback: Not allowed to calculate the amount of feedback.
- Heavy fuel judgment: Not allowed to carry out the heavy judgment.
- Fuel cut control: Not allowed to cut the over pressure charged fuel.

9. ECM OPERATION AT DTC SETTING

Memorize the freeze frame data. (For test mode \$02)

K: DTC P0101 MASS OR VOLUME AIR FLOW CIRCUIT RANGE/PERFORMANCE

1. OUTLINE OF DIAGNOSIS

Detect the malfunction of air flow sensor output property. Judge Low side NG when the air flow voltage indicates low value in spite of the driving condition that the air flow voltage might be high; otherwise, judge High side NG when the air flow voltage indicates high value in spite of the driving condition that the air flow voltage might be low. Judge air flow sensor property NG when the Low side or High side becomes NG.

2. COMPONENT DESCRIPTION

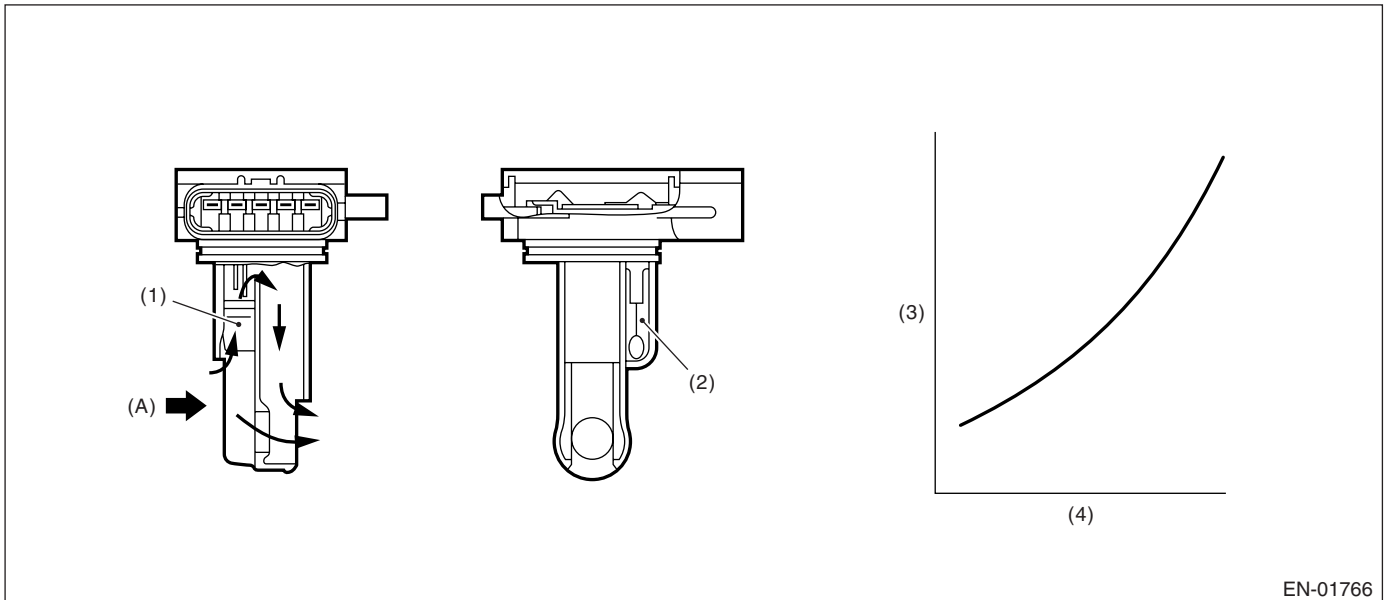

EN-01766

- (1) Air flow sensor
 - (2) Intake air temperature sensor
 - (3) Voltage (V)
 - (4) Intake air volume (kg/s)
- (A) Air

3. ENABLE CONDITION

Secondary Parameters	Enable Conditions
Engine coolant temperature	$\geq 70^{\circ}\text{C}$ (158°F)

4. GENERAL DRIVING CYCLE

Perform the diagnosis continuously after idling.

Diagnostic Trouble Code (DTC) Detecting Criteria

GENERAL DESCRIPTION

5. DIAGNOSTIC METHOD

• Abnormality Judgment

Judge NG when the continuous time of completing the malfunction criteria below becomes more than the time needed for diagnosis.

Judgment Value

Malfunction Criteria	Threshold Value
Low side NG Output voltage Engine speed Throttle angle Intake manifold pressure	< 1.5 V ≥ 2,500 rpm ≥ 15° ≥ 53.3 kPa (400 mmHg, 15.7 inHg)
High side NG 1 Output voltage Engine speed Throttle angle Intake manifold pressure	≥ 1.95 V 600 ↔ 900 rpm < 4.1° < 52.7 kPa (395 mmHg, 15.6 inHg)
High side NG 2 Output voltage Engine speed Throttle angle Intake manifold pressure Diagnosis for fuel system	≥ 1.7 V 600 ↔ 900 rpm < 4.1° < 52.7 kPa (395 mmHg, 15.6 inHg) Rich side malfunction

Time Needed for Diagnosis:

Low side	3 seconds
High side	10 seconds

Malfunction Indicator Light Illumination: Illuminates when malfunction occurs in 2 continuous driving cycles.

• Normality Judgment

Judge OK the when the malfunction criteria below are completed.

Judgment Value

Malfunction Criteria	Threshold Value
Low side NG Output voltage Engine speed Throttle angle Intake manifold pressure	≥ 1.5 V ≥ 2,500 rpm ≥ 15° ≥ 53.3 kPa (400 mmHg, 15.7 inHg)
High side NG Output voltage Engine speed Throttle angle Intake manifold pressure	< 1.95 V 600 ↔ 900 rpm < 4.1° < 52.7 kPa (395 mmHg, 15.6 inHg)

6. DTC CLEAR CONDITION

- When the OK idling cycle was completed 40 times in a row
- When "Clear Memory" was performed

Diagnostic Trouble Code (DTC) Detecting Criteria

GENERAL DESCRIPTION

7. MALFUNCTION INDICATOR LIGHT CLEAR CONDITION

- When the OK driving cycle was completed 3 times in a row
- When "Clear Memory" was performed

8. FAIL SAFE

- Air flow meter: Engine load is normally calculated by manifold pressure and engine speed; however, calculated only by manifold pressure.
- EVAP conc. learning (fuel): Not allowed to learn.
- Knock compensation:
 - Knock compensation final timing advance and retard value = knock compensation + whole learning compensation value + partial learning compensation value.
 - At normal: knock compensation = 0°CA is fixed.
 - At trouble: knock compensation ≠ 0°CA is fixed. (Retard max. 12°CA at knock.)
 - Not allowed to update the whole learning compensation factor.
 - Not allowed to calculate the partial learning zone compensation value.
- ISC control: Make the open loop compensation to be the given value (1 g/s). Stop calculating the throttle sensor temperature compensation. (Hold the previous value.)
- Purge control: Not allowed to purge.

9. ECM OPERATION AT DTC SETTING

Memorize the freeze frame data. (For test mode \$02)

Diagnostic Trouble Code (DTC) Detecting Criteria

GENERAL DESCRIPTION

L: DTC P0102 MASS OR VOLUME AIR FLOW CIRCUIT LOW INPUT

1. OUTLINE OF DIAGNOSIS

Detect the open or short circuit of air flow sensor. Judge NG when out of the standard value.

2. COMPONENT DESCRIPTION

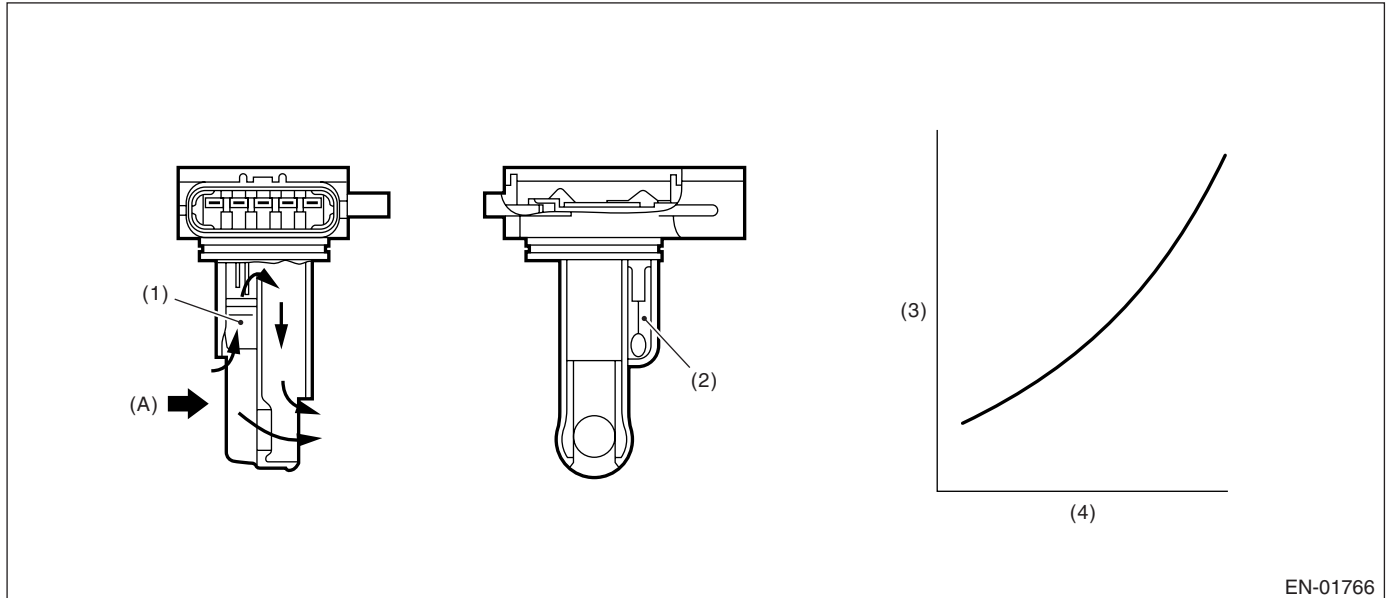

- (1) Air flow sensor
- (2) Intake air temperature sensor
- (3) Voltage (V)
- (4) Intake air volume (kg/s)
- (A) Air

3. ENABLE CONDITION

Secondary Parameters	Enable Conditions
None	

4. GENERAL DRIVING CYCLE

Always perform the diagnosis continuously.

5. DIAGNOSTIC METHOD

Judge NG when the continuous time of completing the malfunction criteria below becomes more than 0.5 seconds. Judge OK and clear the NG when the malfunction criteria below are not completed.

Judgment Value

Malfunction Criteria	Threshold Value
Output voltage	≤ 0.2 V

Time Needed for Diagnosis: 0.5 seconds

Malfunction Indicator Light Illumination: Illuminates as soon as the malfunction occurs.

6. DTC CLEAR CONDITION

- When the OK idling cycle was completed 40 times in a row
- When "Clear Memory" was performed

7. MALFUNCTION INDICATOR LIGHT CLEAR CONDITION

- When the OK driving cycle was completed 3 times in a row
- When "Clear Memory" was performed

Diagnostic Trouble Code (DTC) Detecting Criteria

GENERAL DESCRIPTION

8. FAIL SAFE

- Air flow meter: Engine load is normally calculated by manifold pressure and engine speed; however, calculated only by manifold pressure.
- EVAP conc. learning (fuel): Not allowed to learn.
- Knock compensation:
 - Knock compensation final timing advance and retard value = knock compensation + whole learning compensation value + partial learning compensation value.
 - At normal: knock compensation = 0°CA is fixed.
 - At trouble: knock compensation ≠ 0°CA is fixed. (Retard max. 12°CA at knock.)
 - Not allowed to update the whole learning compensation factor.
 - Not allowed to calculate the partial learning zone compensation value.
- ISC control: Make the open loop compensation to be the given value (1 g/s). Stop calculating the throttle sensor temperature compensation. (Hold the previous value.)
- Purge control: Not allowed to purge.

9. ECM OPERATION AT DTC SETTING

Memorize the freeze frame data. (For test mode \$02)

Diagnostic Trouble Code (DTC) Detecting Criteria

GENERAL DESCRIPTION

M: DTC P0103 MASS OR VOLUME AIR FLOW CIRCUIT HIGH INPUT

1. OUTLINE OF DIAGNOSIS

Detect the open or short circuit of air flow sensor. Judge NG when out of the standard value.

2. COMPONENT DESCRIPTION

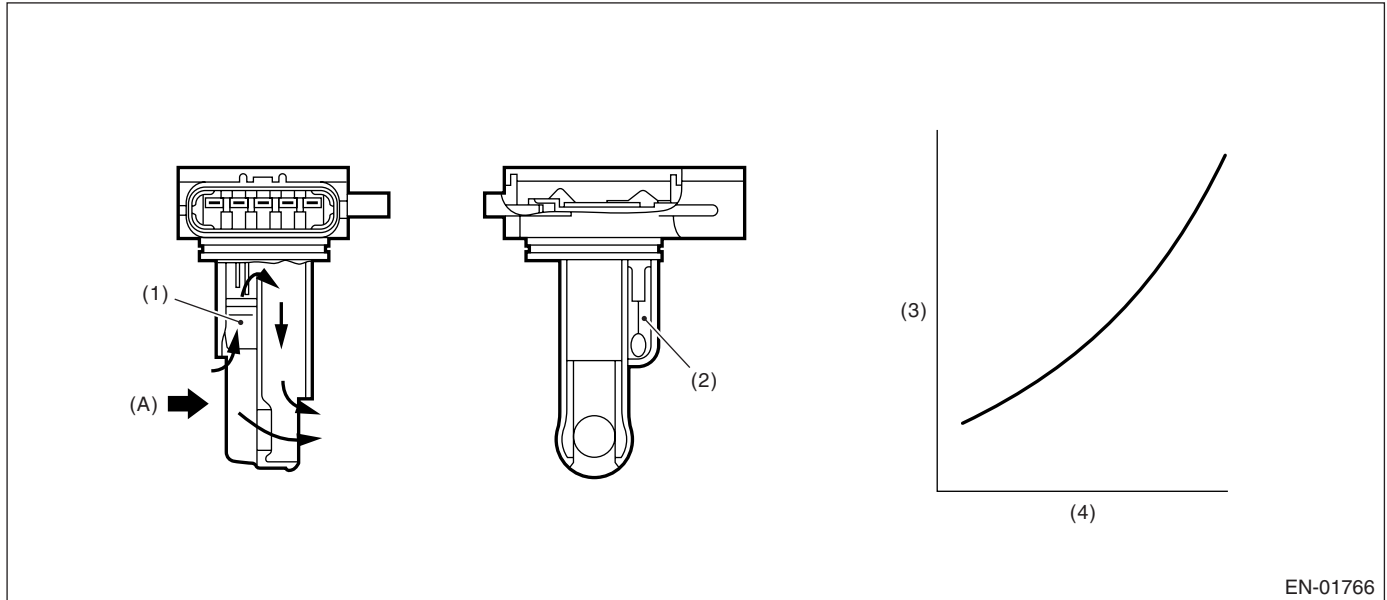

- (1) Air flow sensor
 - (2) Intake air temperature sensor
 - (3) Voltage (V)
 - (4) Intake air volume (kg/s)
- (A) Air

EN-01766

3. ENABLE CONDITION

Secondary Parameters	Enable Conditions
None	

4. GENERAL DRIVING CYCLE

Always perform the diagnosis continuously.

5. DIAGNOSTIC METHOD

Judge NG when the continuous time until completing the malfunction criteria below becomes more than 0.5 seconds. Judge OK and clear the NG when the malfunction criteria below are not completed.

Judgment Value

Malfunction Criteria	Threshold Value
Output voltage	≥ 4.985 V

Time Needed for Diagnosis: 0.5 seconds

Malfunction Indicator Light Illumination: Illuminates as soon as the malfunction occurs.

6. DTC CLEAR CONDITION

- When the OK idling cycle was completed 40 times in a row
- When "Clear Memory" was performed

7. MALFUNCTION INDICATOR LIGHT CLEAR CONDITION

- When the OK driving cycle was completed 3 times in a row
- When "Clear Memory" was performed

Diagnostic Trouble Code (DTC) Detecting Criteria

GENERAL DESCRIPTION

8. FAIL SAFE

- Air flow meter: Engine load is normally calculated by manifold pressure and engine speed; however, calculated only by manifold pressure.
- EVAP conc. learning (fuel): Not allowed to learn.
- Knock compensation:
 - Knock compensation final timing advance and retard value = knock compensation + whole learning compensation value + partial learning compensation value.
 - At normal: knock compensation = 0°CA is fixed.
 - At trouble: knock compensation ≠ 0°CA is fixed. (Retard max. 12°CA at knock.)
 - Not allowed to update the whole learning compensation factor.
 - Not allowed to calculate the partial learning zone compensation value.
- ISC control: Make the open loop compensation to be the given value (1 g (0.04 oz)/s). Stop calculating the throttle sensor temperature compensation. (Hold the previous value.)
- Purge control: Not allowed to purge.

9. ECM OPERATION AT DTC SETTING

Memorize the freeze frame data. (For test mode \$02)

Diagnostic Trouble Code (DTC) Detecting Criteria

GENERAL DESCRIPTION

N: DTC P0107 MANIFOLD ABSOLUTE PRESSURE/BAROMETRIC PRESSURE CIRCUIT LOW INPUT

1. OUTLINE OF DIAGNOSIS

Detect the open or short circuit of intake manifold pressure sensor. Judge NG when out of the standard value.

2. COMPONENT DESCRIPTION

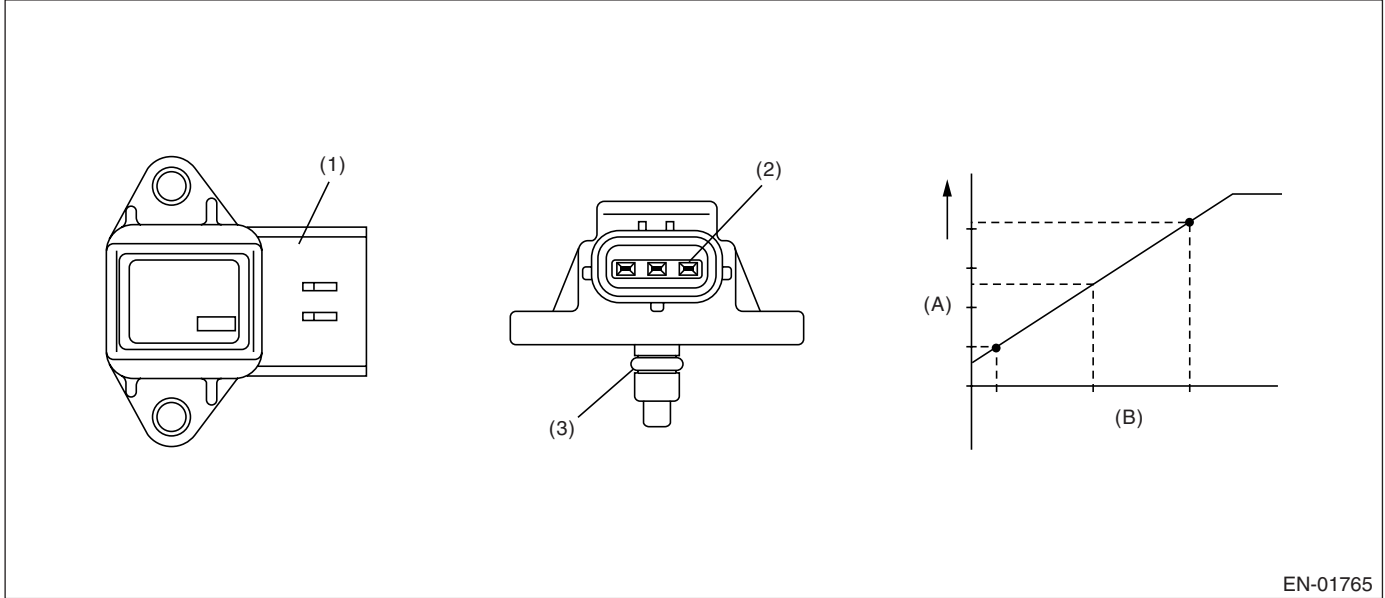

- (1) Connector
- (2) Terminal
- (3) O-ring

- (A) Output voltage
- (B) Absolute pressure

3. ENABLE CONDITION

Secondary Parameters	Enable Conditions
Battery voltage	$\geq 10.9 \text{ V}$

4. GENERAL DRIVING CYCLE

Always perform the diagnosis continuously.

5. DIAGNOSTIC METHOD

Judge NG when the continuous time of completing the malfunction criteria below becomes more than 0.5 seconds. Judge OK and clear the NG when the malfunction criteria below are not completed.

Judgment Value

Malfunction Criteria	Threshold Value
Output voltage	$< 0.568 \text{ V}$

Time Needed for Diagnosis: 0.5 seconds

Malfunction Indicator Light Illumination: Illuminates as soon as the malfunction occurs.

6. DTC CLEAR CONDITION

- When the OK idling cycle was completed 40 times in a row
- When "Clear Memory" was performed

Diagnostic Trouble Code (DTC) Detecting Criteria

GENERAL DESCRIPTION

7. MALFUNCTION INDICATOR LIGHT CLEAR CONDITION

- When the OK driving cycle was completed 3 times in a row
- When “Clear Memory” was performed

8. FAIL SAFE

- Intake manifold pressure sensor process: Estimate the pressure from engine load.
- ISC feedback: Not allowed to calculate the amount of feedback.
- Heavy fuel judgment: Not allowed to carry out the heavy judgment.
- Fuel cut control: Not allowed to cut the over pressure charged fuel.

9. ECM OPERATION AT DTC SETTING

Memorize the freeze frame data. (For test mode \$02)

Diagnostic Trouble Code (DTC) Detecting Criteria

GENERAL DESCRIPTION

O: DTC P0108 MANIFOLD ABSOLUTE PRESSURE/BAROMETRIC PRESSURE CIRCUIT HIGH INPUT

1. OUTLINE OF DIAGNOSIS

Detect the open or short circuit of intake manifold pressure sensor. Judge NG when out of the standard value.

2. COMPONENT DESCRIPTION

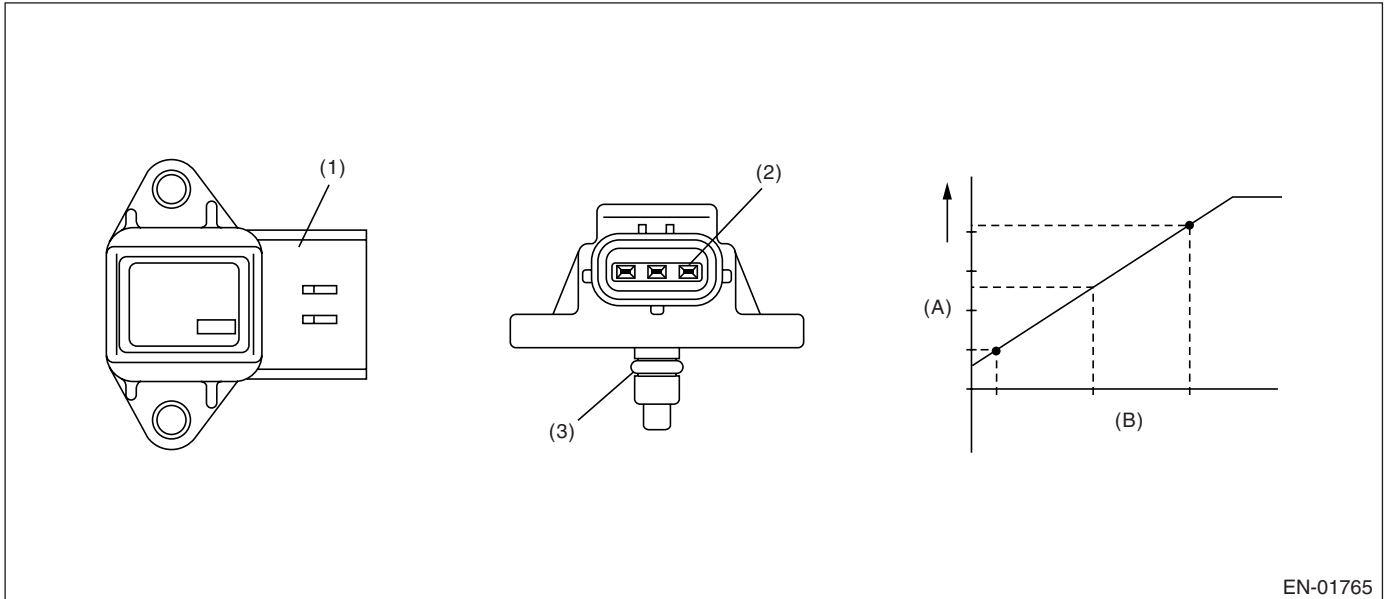

- (1) Connector
- (2) Terminal
- (3) O-ring

- (A) Output voltage
- (B) Absolute pressure

EN-01765

3. ENABLE CONDITION

Secondary Parameters	Enable Conditions
Battery voltage	$\geq 10.9 \text{ V}$

4. GENERAL DRIVING CYCLE

Always perform the diagnosis continuously.

5. DIAGNOSTIC METHOD

Judge NG when the continuous time of completing the malfunction criteria below becomes more than 0.5 seconds. Judge OK and clear the NG when the malfunction criteria below are not completed.

Judgment Value

Malfunction Criteria	Threshold Value
Output voltage	$\geq 4.93 \text{ V}$

Time Needed for Diagnosis: 0.5 seconds

Malfunction Indicator Light Illumination: Illuminates as soon as the malfunction occurs.

6. DTC CLEAR CONDITION

- When the OK idling cycle was completed 40 times in a row
- When "Clear Memory" was performed

Diagnostic Trouble Code (DTC) Detecting Criteria

GENERAL DESCRIPTION

7. MALFUNCTION INDICATOR LIGHT CLEAR CONDITION

- When the OK driving cycle was completed 3 times in a row
- When "Clear Memory" was performed

8. FAIL SAFE

- Intake manifold pressure sensor process: Estimate the pressure from engine load.
- ISC feedback: Not allowed to calculate the amount of feedback.
- Heavy fuel judgment: Not allowed to carry out the heavy judgment.
- Fuel cut control: Not allowed to cut the over pressure charged fuel.

9. ECM OPERATION AT DTC SETTING

Memorize the freeze frame data. (For test mode \$02)

Diagnostic Trouble Code (DTC) Detecting Criteria

GENERAL DESCRIPTION

P: DTC P0111 INTAKE AIR TEMPERATURE CIRCUIT RANGE/PERFORMANCE

1. OUTLINE OF DIAGNOSIS

Detect the malfunction of intake air temperature sensor output property. Judge NG when the intake air temperature is not varied whereas it seemed to be varied from the viewpoint of engine condition.

2. COMPONENT DESCRIPTION

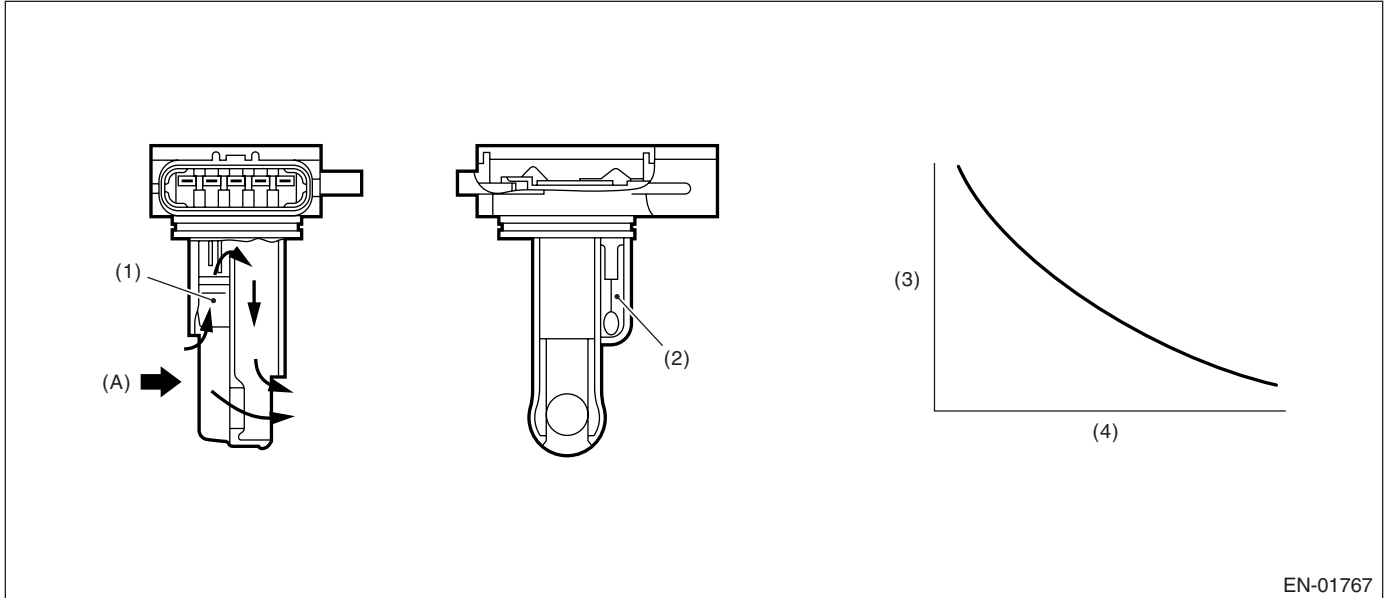

- (1) Air flow sensor
 - (2) Intake air temperature sensor
 - (3) Resistance value (Ω)
 - (4) Intake air temperature $^{\circ}\text{C}$ ($^{\circ}\text{F}$)
- (A) Air

3. ENABLE CONDITION

Secondary Parameters	Enable Conditions
Coolant temp. before engine start	< 30°C (86°F)
Engine coolant temperature	> 95°C (203°F)
Battery voltage	≥ 10.9 V
Continuous time when the vehicle speed is less than 50 km/h (31 MPH)	600 seconds or more

4. GENERAL DRIVING CYCLE

Perform the diagnosis when the vehicle speed condition is completed after idling from starting the cooled engine.

5. DIAGNOSTIC METHOD

• Abnormality Judgment

Judge NG when the continuous time of completing the malfunction criteria below becomes more than 1 second.

Judgment Value

Malfunction Criteria	Threshold Value
Output voltage difference between Max. and Min.	< 20 mV (It is equal to approx. 0.5°C (0.9°F) around 25° (77°F).)

Time Needed for Diagnosis: 1 second

Diagnostic Trouble Code (DTC) Detecting Criteria

GENERAL DESCRIPTION

Malfunction Indicator Light Illumination: Illuminates when malfunction occurs in 2 continuous driving cycles.

• Normality Judgment

Judge OK and clear the NG when the malfunction criteria below are completed.

Judgment Value

Malfunction Criteria	Threshold Value
Output voltage difference between Max. and Min.	≥ 20 mV

6. DTC CLEAR CONDITION

- When the OK idling cycle was completed 40 times in a row
- When "Clear Memory" was performed

7. MALFUNCTION INDICATOR LIGHT CLEAR CONDITION

- When the OK driving cycle was completed 3 times in a row
- When "Clear Memory" was performed

8. FAIL SAFE

Intake air temperature sensor process: Intake air temperature is fixed at 20°C (68°F).

9. ECM OPERATION AT DTC SETTING

Memorize the freeze frame data. (For test mode \$02)

Diagnostic Trouble Code (DTC) Detecting Criteria

GENERAL DESCRIPTION

Q: DTC P0112 INTAKE AIR TEMPERATURE CIRCUIT LOW INPUT

1. OUTLINE OF DIAGNOSIS

Detect the open or short circuit of intake air temperature sensor. Judge NG when out of the standard value.

2. COMPONENT DESCRIPTION

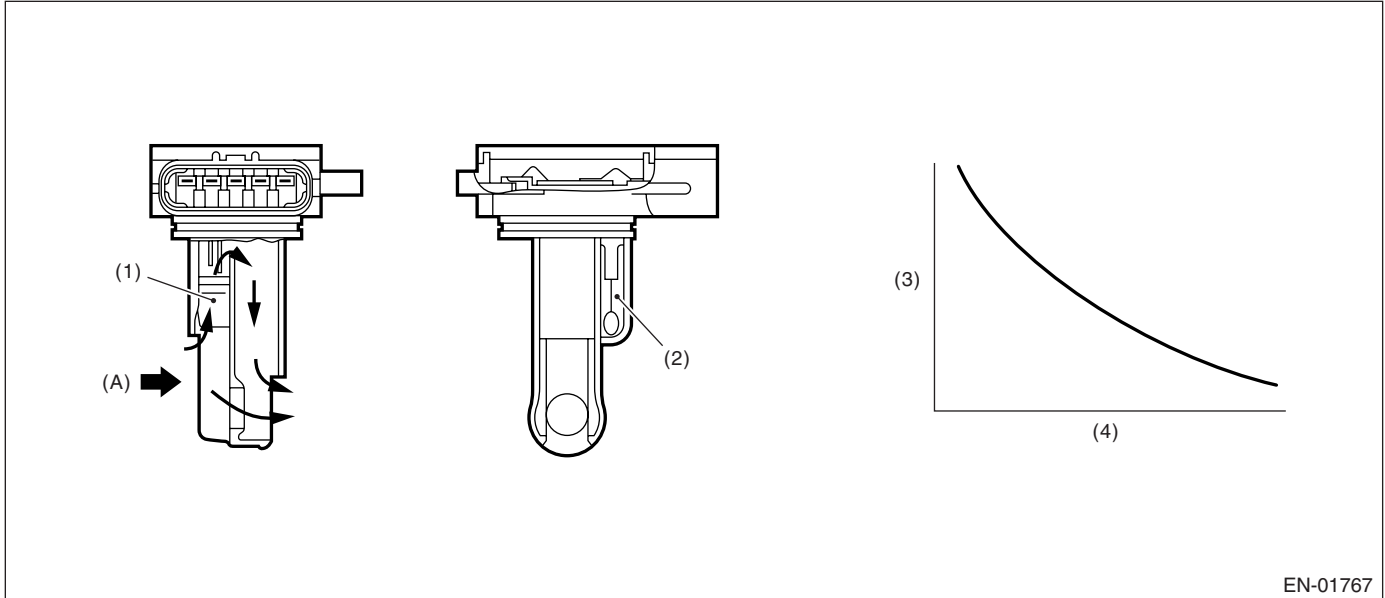

EN-01767

- (1) Air flow sensor
 - (2) Intake air temperature sensor
 - (3) Resistance value (Ω)
 - (4) Intake air temperature $^{\circ}\text{C}$ ($^{\circ}\text{F}$)
- (A) Air

3. ENABLE CONDITION

Secondary Parameters	Enable Conditions
None	

4. GENERAL DRIVING CYCLE

Always perform the diagnosis continuously.

5. DIAGNOSTIC METHOD

• Abnormality Judgment

Judge NG when the continuous time of completing the malfunction criteria below becomes more than 0.5 seconds.

Judgment Value

Malfunction Criteria	Threshold Value
Output voltage	< 0.165 V
Ignition switch	ON

Time Needed for Diagnosis: 0.5 seconds

Malfunction Indicator Light Illumination: Illuminates as soon as the malfunction occurs.

Diagnostic Trouble Code (DTC) Detecting Criteria

GENERAL DESCRIPTION

• Normality Judgment

Judge OK and clear the NG when the malfunction criteria below are completed.

Judgment Value

Malfunction Criteria	Threshold Value
Output voltage	≥ 0.165 V
Ignition switch	ON

6. DTC CLEAR CONDITION

- When the OK idling cycle was completed 40 times in a row
- When "Clear Memory" was performed

7. MALFUNCTION INDICATOR LIGHT CLEAR CONDITION

- When the OK driving cycle was completed 3 times in a row
- When "Clear Memory" was performed

8. FAIL SAFE

Intake air temperature sensor process: Intake air temperature is fixed at 20°C (68°F).

9. ECM OPERATION AT DTC SETTING

Memorize the freeze frame data. (For test mode \$02)

Diagnostic Trouble Code (DTC) Detecting Criteria

GENERAL DESCRIPTION

R: DTC P0113 INTAKE AIR TEMPERATURE CIRCUIT HIGH INPUT

1. OUTLINE OF DIAGNOSIS

Detect the open or short circuit of intake air temperature sensor. Judge NG when out of the standard value.

2. COMPONENT DESCRIPTION

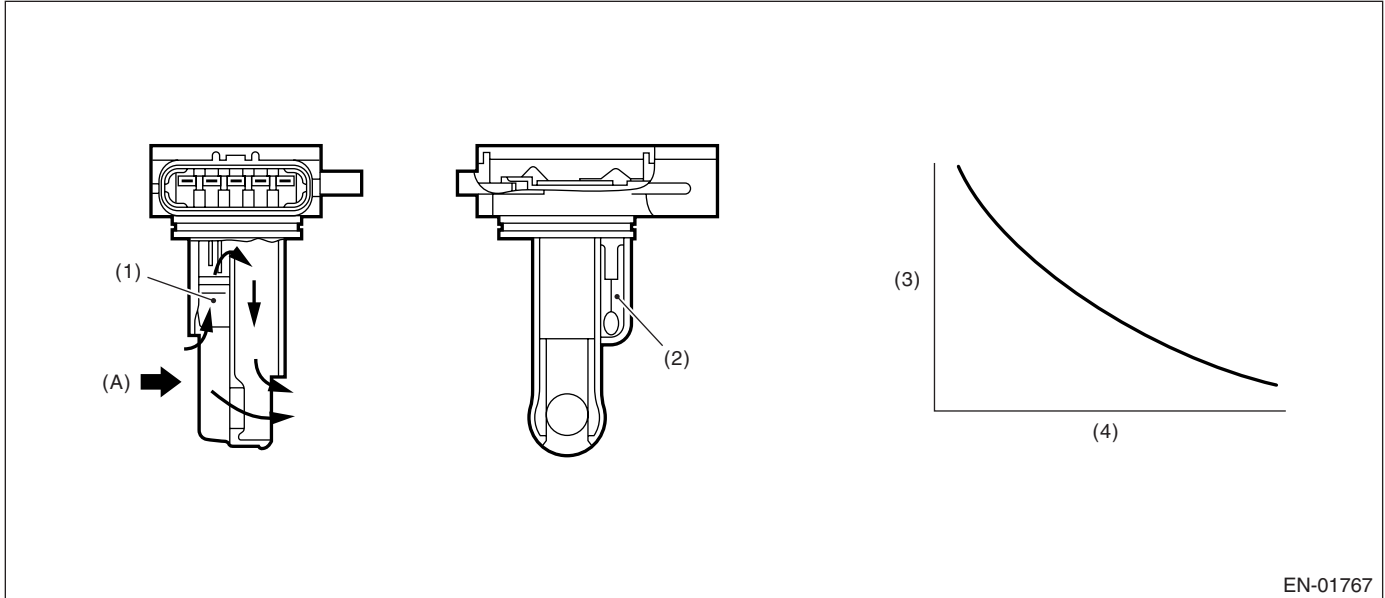

EN-01767

- (1) Air flow sensor
 - (2) Intake air temperature sensor
 - (3) Resistance value (Ω)
 - (4) Intake air temperature $^{\circ}\text{C}$ ($^{\circ}\text{F}$)
- (A) Air

3. ENABLE CONDITION

Secondary Parameters	Enable Conditions
None	

4. GENERAL DRIVING CYCLE

Always perform the diagnosis continuously.

5. DIAGNOSTIC METHOD

• Abnormality Judgment

Judge NG when the continuous time of completing the malfunction criteria below becomes more than 0.5 seconds.

Judgment Value

Malfunction Criteria	Threshold Value
Output voltage	$\geq 4.72 \text{ V}$
Ignition switch	ON

Time Needed for Diagnosis: 0.5 seconds

Malfunction Indicator Light Illumination: Illuminates as soon as the malfunction occurs.

Diagnostic Trouble Code (DTC) Detecting Criteria

GENERAL DESCRIPTION

• Normality Judgment

Judge OK and clear the NG when the malfunction criteria below are completed.

Judgment Value

Malfunction Criteria	Threshold Value
Output voltage	≥ 0.23 V
Ignition switch	ON

6. DTC CLEAR CONDITION

- When the OK idling cycle was completed 40 times in a row
- When "Clear Memory" was performed

7. MALFUNCTION INDICATOR LIGHT CLEAR CONDITION

- When the OK driving cycle was completed 3 times in a row
- When "Clear Memory" was performed

8. FAIL SAFE

Intake air temperature sensor process: Intake air temperature is fixed at 20°C (68°F).

9. ECM OPERATION AT DTC SETTING

Memorize the freeze frame data. (For test mode \$02)

Diagnostic Trouble Code (DTC) Detecting Criteria

GENERAL DESCRIPTION

S: DTC P0117 ENGINE COOLANT TEMPERATURE CIRCUIT LOW INPUT

1. OUTLINE OF DIAGNOSIS

Detect the open or short circuit of engine coolant temperature sensor. Judge NG when out of the standard value.

2. COMPONENT DESCRIPTION

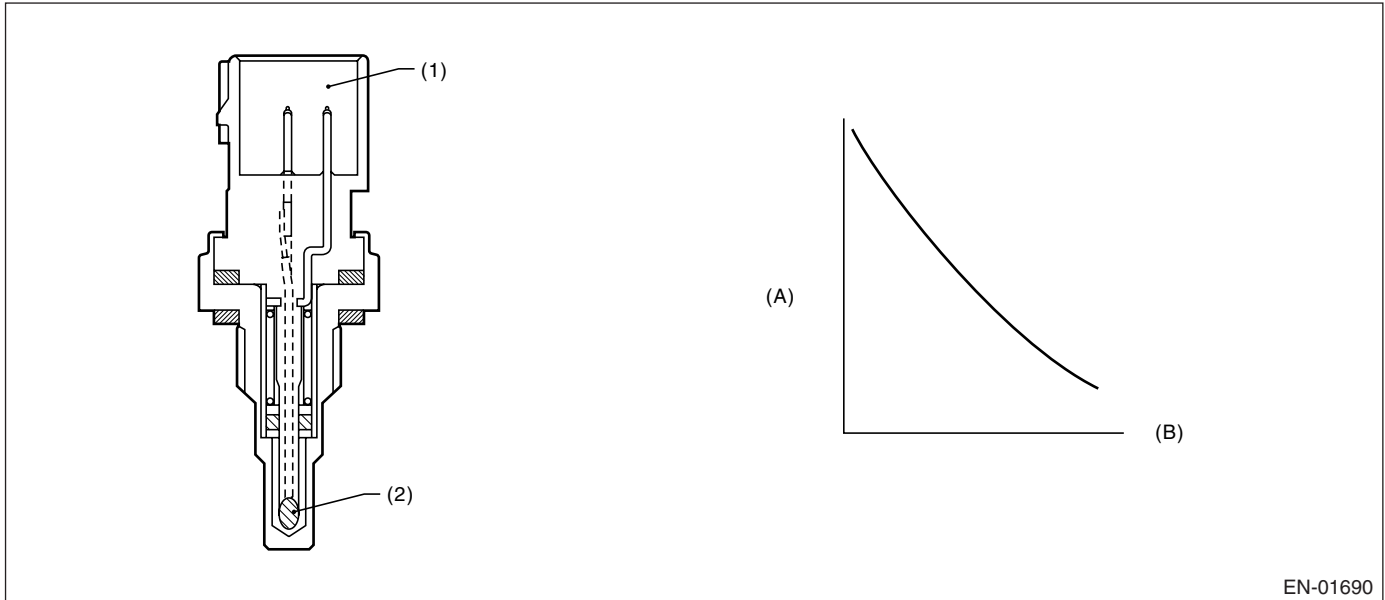

- (1) Connector
- (2) Thermistor element

- (A) Resistance value (kΩ)
- (B) Temperature °C (°F)

EN-01690

3. ENABLE CONDITION

Secondary Parameters	Enable Conditions
None	

4. GENERAL DRIVING CYCLE

Always perform the diagnosis continuously.

5. DIAGNOSTIC METHOD

Judge NG when the continuous time of completing the malfunction criteria below becomes more than 0.5 seconds. Judge OK and clear the NG when the malfunction criteria below are not completed.

Judgment Value

Malfunction Criteria	Threshold Value
Output voltage	< 0.165 V

Time Needed for Diagnosis: 0.5 seconds

Malfunction Indicator Light Illumination: Illuminates as soon as the malfunction occurs.

6. DTC CLEAR CONDITION

- When the OK idling cycle was completed 40 times in a row
- When "Clear Memory" was performed

7. MALFUNCTION INDICATOR LIGHT CLEAR CONDITION

- When the OK driving cycle was completed 3 times in a row
- When "Clear Memory" was performed

Diagnostic Trouble Code (DTC) Detecting Criteria

GENERAL DESCRIPTION

8. FAIL SAFE

- Engine coolant temperature process: Fix the engine coolant temperature at 70°C (158°F).
- ISC feedback: Calculate the target engine speed setting the engine coolant temperature to 70°C (158°F).
- ISC learning: Not allowed to learn.
- Heavy fuel judgment control: Not allowed to carry out the heavy judgment.
- Air conditioner control: Not allowed to turn the air conditioner to ON.
- Radiator fan control: Both main and sub fan are in High driving.
- Increase compensation factor at high engine coolant temperature: Increase normally occurs with high temperature and other conditions; however, occurs with other conditions except engine coolant temperature condition.
- AVCS control: Make the oil flow control valve driving output to be Duty=0%.
- Tumble generator valve control: Open the tumble generator valve.

9. ECM OPERATION AT DTC SETTING

Memorize the freeze frame data. (For test mode \$02)

Diagnostic Trouble Code (DTC) Detecting Criteria

GENERAL DESCRIPTION

T: DTC P0118 ENGINE COOLANT TEMPERATURE CIRCUIT HIGH INPUT

1. OUTLINE OF DIAGNOSIS

Detect the open or short circuit of engine coolant temperature sensor. Judge NG when out of the standard value.

2. COMPONENT DESCRIPTION

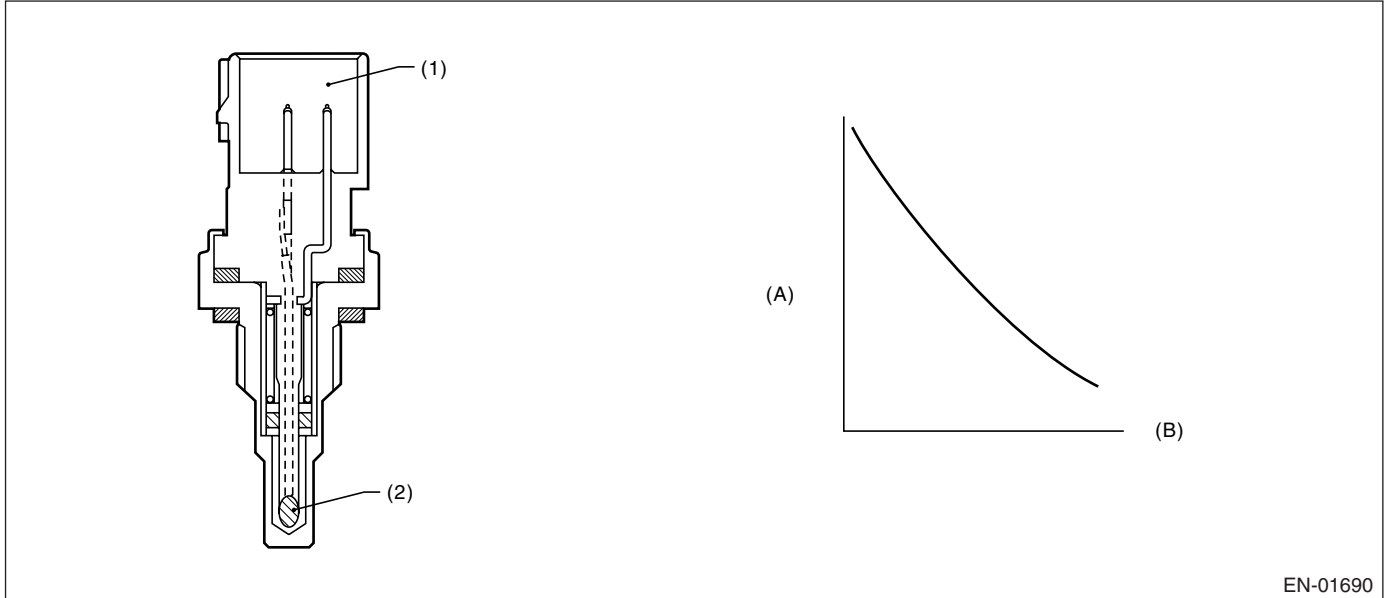

- (1) Connector
- (2) Thermistor element

- (A) Resistance value (kΩ)
- (B) Temperature °C (°F)

EN-01690

3. ENABLE CONDITION

Secondary Parameters	Enable Conditions
None	

4. GENERAL DRIVING CYCLE

Always perform the diagnosis continuously.

5. DIAGNOSTIC METHOD

Judge NG when the continuous time of completing the malfunction criteria below becomes more than 0.5 seconds. Judge OK and clear the NG when the malfunction criteria below are not completed.

Judgment Value

Malfunction Criteria	Threshold Value
Output voltage	≥ 4.72 V

Time Needed for Diagnosis: 0.5 seconds

Malfunction Indicator Light Illumination: Illuminates as soon as the malfunction occurs.

6. DTC CLEAR CONDITION

- When the OK idling cycle was completed 40 times in a row
- When "Clear Memory" was performed

7. MALFUNCTION INDICATOR LIGHT CLEAR CONDITION

- When the OK driving cycle was completed 3 times in a row
- When "Clear Memory" was performed

Diagnostic Trouble Code (DTC) Detecting Criteria

GENERAL DESCRIPTION

8. FAIL SAFE

- Engine coolant temperature process: Fix the engine coolant temperature at 70°C (158°F).
- ISC feedback: Calculate the target engine speed setting the engine coolant temperature to 70°C (158°F).
- ISC learning: Not allowed to learn.
- Heavy fuel judgment control: Not allowed to carry out the heavy judgment.
- Air conditioner control: Not allowed to turn the air conditioner to ON.
- Radiator fan control: Both main and sub fan are in High driving.
- Increase compensation factor at high engine coolant temperature: Increase normally occurs with high temperature and other conditions; however, occurs with other conditions except engine coolant temperature condition.
- AVCS control: Make the oil flow control valve driving output to be Duty=0%.
- Tumble generator valve control: Open the tumble generator valve.

9. ECM OPERATION AT DTC SETTING

Memorize the freeze frame data. (For test mode \$02)

Diagnostic Trouble Code (DTC) Detecting Criteria

GENERAL DESCRIPTION

U: DTC P0122 THROTTLE/PEDAL POSITION SENSOR/SWITCH “A” CIRCUIT LOW INPUT

1. OUTLINE OF DIAGNOSIS

Detect the open or short circuit of throttle position sensor 1.
Judge NG when out of the standard value.

2. COMPONENT DESCRIPTION

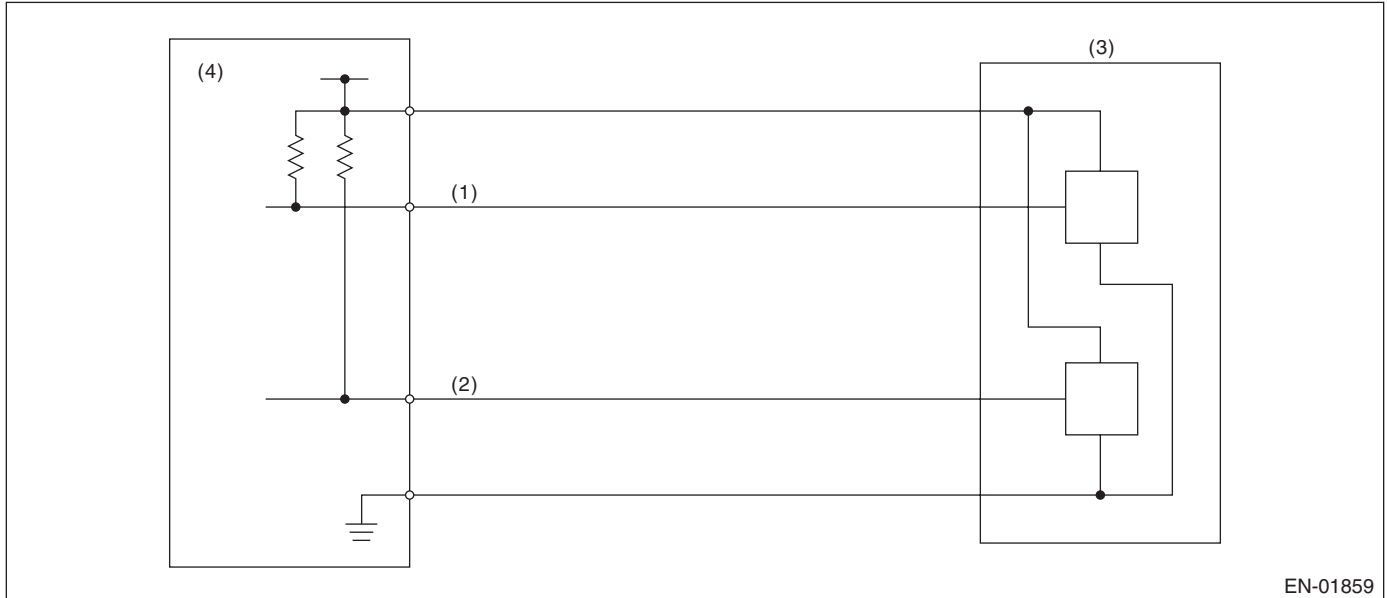

- (1) Throttle position sensor 1 signal (3) Throttle position sensor
(2) Throttle position sensor 2 signal (4) Engine control module (ECM)

3. ENABLE CONDITION

Secondary Parameters	Enable Conditions
Ignition switch	ON

4. GENERAL DRIVING CYCLE

Always perform the diagnosis continuously.

5. DIAGNOSTIC METHOD

Judge OK and clear the NG when the malfunction criteria below are completed.

Judgment Value

Malfunction Criteria	Threshold Value
Sensor 1 input voltage	≤ 0.224 V

Time Needed for Diagnosis: 24 milliseconds

Malfunction Indicator Light Illumination: Illuminates as soon as malfunction occurs.

6. DTC CLEAR CONDITION

- When the OK idling cycle was completed 40 times in a row
- When “Clear Memory” was performed (Only with engine stopped)

7. MALFUNCTION INDICATOR LIGHT CLEAR CONDITION

- When the OK driving cycle was completed 3 times in a row
- When “Clear Memory” was performed (Only with engine stopped)

8. FAIL SAFE

Stop power distribution to electronic throttle control motor. (Throttle opening is fixed to 6°.)

9. ECM OPERATION AT DTC SETTING

Memorize the freeze frame data. (For test mode \$02)

V: DTC P0123 THROTTLE/PEDAL POSITION SENSOR/SWITCH "A" CIRCUIT HIGH INPUT

1. OUTLINE OF DIAGNOSIS

Detect the open or short circuit of throttle position sensor 1.
Judge NG when out of the standard value.

2. COMPONENT DESCRIPTION

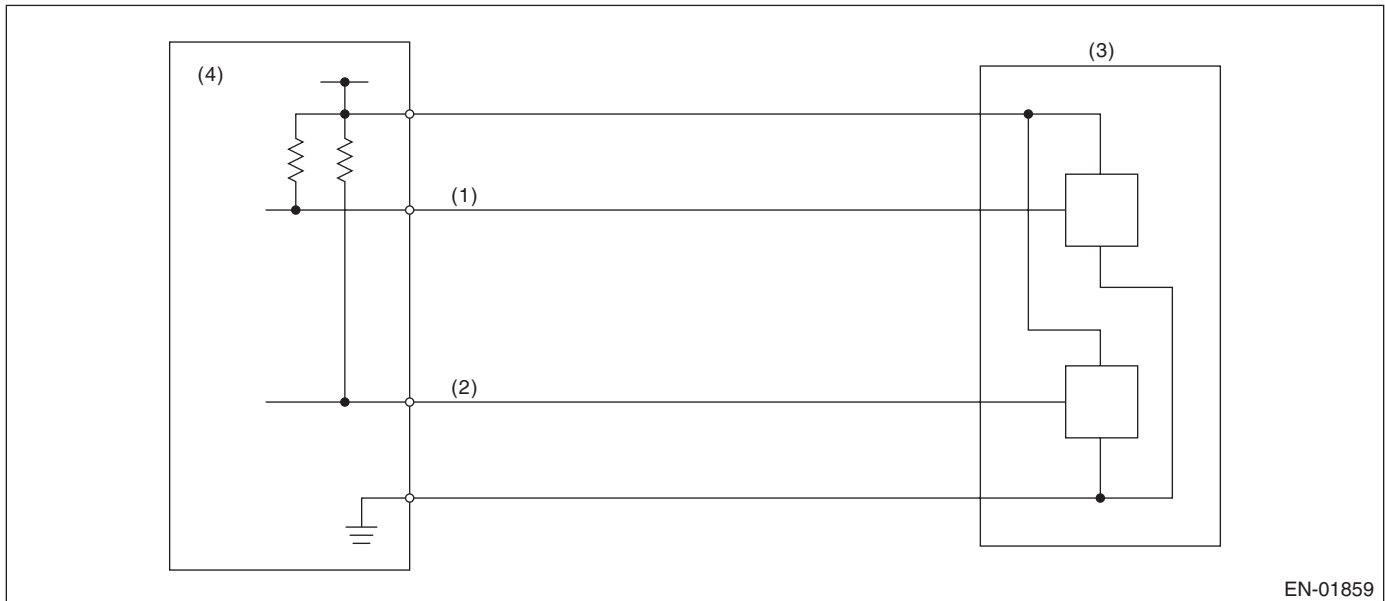

- | | |
|---------------------------------------|---------------------------------|
| (1) Throttle position sensor 1 signal | (3) Throttle position sensor |
| (2) Throttle position sensor 2 signal | (4) Engine control module (ECM) |

3. ENABLE CONDITION

Secondary Parameters	Enable Conditions
Ignition switch	ON

4. GENERAL DRIVING CYCLE

Always perform the diagnosis continuously.

5. DIAGNOSTIC METHOD

Judge OK and clear the NG when the malfunction criteria below are completed.

Judgment Value

Malfunction Criteria	Threshold Value
Sensor 1 input voltage	≤ 4.851 V

Time Needed for Diagnosis: 24 milliseconds

Malfunction Indicator Light Illumination: Illuminates as soon as malfunction occurs.

Diagnostic Trouble Code (DTC) Detecting Criteria

GENERAL DESCRIPTION

6. DTC CLEAR CONDITION

- When the OK idling cycle was completed 40 times in a row
- When "Clear Memory" was performed (Only with engine stopped)

7. MALFUNCTION INDICATOR LIGHT CLEAR CONDITION

- When the OK driving cycle was completed 3 times in a row
- When "Clear Memory" was performed (Only with engine stopped)

8. FAIL SAFE

Stop power distribution to electronic throttle control motor. (Throttle opening is fixed to 6°.)

9. ECM OPERATION AT DTC SETTING

Memorize the freeze frame data. (For test mode \$02)

Diagnostic Trouble Code (DTC) Detecting Criteria

GENERAL DESCRIPTION

W: DTC P0125 INSUFFICIENT COOLANT TEMPERATURE FOR CLOSED LOOP FUEL CONTROL

1. OUTLINE OF DIAGNOSIS

Detect the malfunction of engine coolant temperature output property. Judge NG when the engine coolant temperature does not rise whereas it seemed to rise from the viewpoint of the engine condition.

2. COMPONENT DESCRIPTION

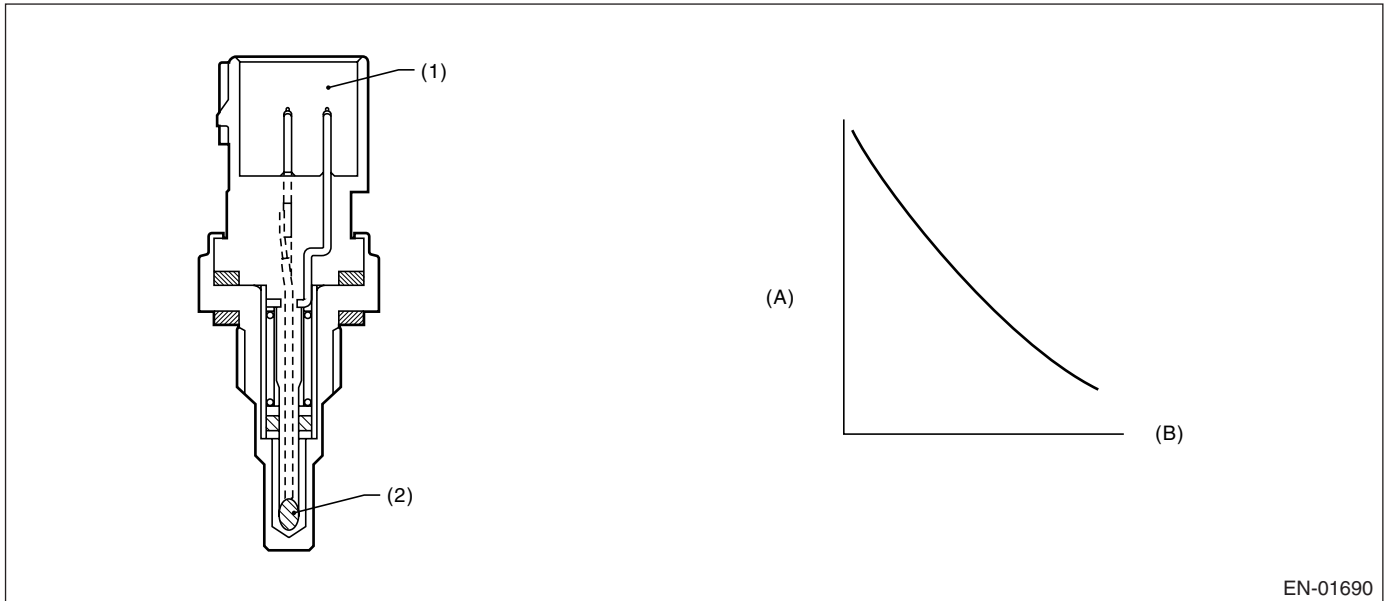

- (1) Connector
- (2) Thermistor element

- (A) Resistance value (kΩ)
- (B) Temperature °C (°F)

EN-01690

3. ENABLE CONDITION

Secondary Parameters	Enable Conditions
Engine speed	≥ 500 rpm
Battery voltage	> 10.9 V

4. GENERAL DRIVING CYCLE

Perform the diagnosis only once after engine starting.

5. DIAGNOSTIC METHOD

• Abnormality Judgment

Judge NG when the malfunction criteria below are completed.

Judgment Value

Malfunction Criteria	Threshold Value
Engine coolant temperature	< 20°C (68°F)
Timer for diagnosis after engine starting	≥ Timer judgment value after engine starting

Timer for diagnosis after engine starting

- a) Timer stop at fuel cut mode.
- b) During the driving conditions (except a) above), timer count up by 64 milliseconds + TWCNT milliseconds at every 64 milliseconds.

Where, TWCNT is determined as follows,

TWCNT = 0 at idle switch ON,

Diagnostic Trouble Code (DTC) Detecting Criteria

GENERAL DESCRIPTION

TWCNT show on the following table at idle switch OFF.

Temperature °C (°F)	Vehicle speed km/h (MPH)							
	0 (0)	8 (4.97)	16 (9.94)	24 (14.9)	32 (19.9)	40 (24.9)	48 (29.8)	56 (34.8)
-20 (-4)	0 ms	37.14 ms	74.27 ms	111.41 ms	126.66 ms	141.91 ms	163.59 ms	185.26 ms
-10 (14)	0 ms	27.39 ms	54.78 ms	82.17 ms	99.65 ms	117.13 ms	135.96 ms	154.80 ms
0 (32)	0 ms	17.65 ms	35.29 ms	52.94 ms	72.64 ms	92.34 ms	108.34 ms	124.33 ms
10 (50)	0 ms	7.90 ms	15.80 ms	23.70 ms	45.63 ms	67.56 ms	80.71 ms	93.87 ms
20 (68)	0 ms	7.90 ms	15.80 ms	23.70 ms	45.63 ms	67.56 ms	80.71 ms	93.87 ms

Judgment value of timer after engine starting

$$t = 451.1 - 25.9 \times T_i$$

T_i is the lowest engine coolant temperature after starting the engine.

Time Needed for Diagnosis: To be determined. (It is varied by the Min. engine coolant temperature and engine conditions such as vehicle speed and engine coolant temperature.)

Malfunction Indicator Light Illumination: Illuminates when malfunction occurs in 2 continuous driving cycles.

• Normality Judgment

Judge OK and clear the NG when the malfunction criteria below are completed.

Judgment Value

Malfunction Criteria	Threshold Value
Engine coolant temperature	$\geq 20^\circ\text{C}$ (68°F)

6. DTC CLEAR CONDITION

- When the OK idling cycle was completed 40 times in a row
- When "Clear Memory" was performed

7. MALFUNCTION INDICATOR LIGHT CLEAR CONDITION

- When the OK driving cycle was completed 3 times in a row
- When "Clear Memory" was performed

8. FAIL SAFE

- Engine coolant temperature process: Fix the engine coolant temperature at 70°C (158°F).
- ISC feedback: Calculate the target engine speed setting the engine coolant temperature to 70°C (158°F).
- ISC learning: Not allowed to learn.
- Heavy fuel judgment control: Not allowed to carry out the heavy judgment.
- Air conditioner control: Not allowed to turn the air conditioner to ON.
- Radiator fan control: Both main and sub fan are in High driving.
- Increase compensation factor at high engine coolant temperature: Increase normally occurs with high temperature and other conditions; however, occurs with other conditions except engine coolant temperature condition.
- AVCS control: Make the oil flow control valve driving output to be Duty=0%.
- Tumble generator valve control: Open the tumble generator valve.

9. ECM OPERATION AT DTC SETTING

Memorize the freeze frame data. (For test mode \$02)

Diagnostic Trouble Code (DTC) Detecting Criteria

GENERAL DESCRIPTION

X: DTC P0126 INSUFFICIENT COOLANT TEMPERATURE FOR STABLE OPERATION

1. OUTLINE OF DIAGNOSIS

Judge NG when the engine coolant temperature sensor output does not change.

Judge NG when the engine coolant temperature sensor output does not change though the vehicle is operated in a manner which is expected to affect the engine coolant temperature.

2. COMPONENT DESCRIPTION

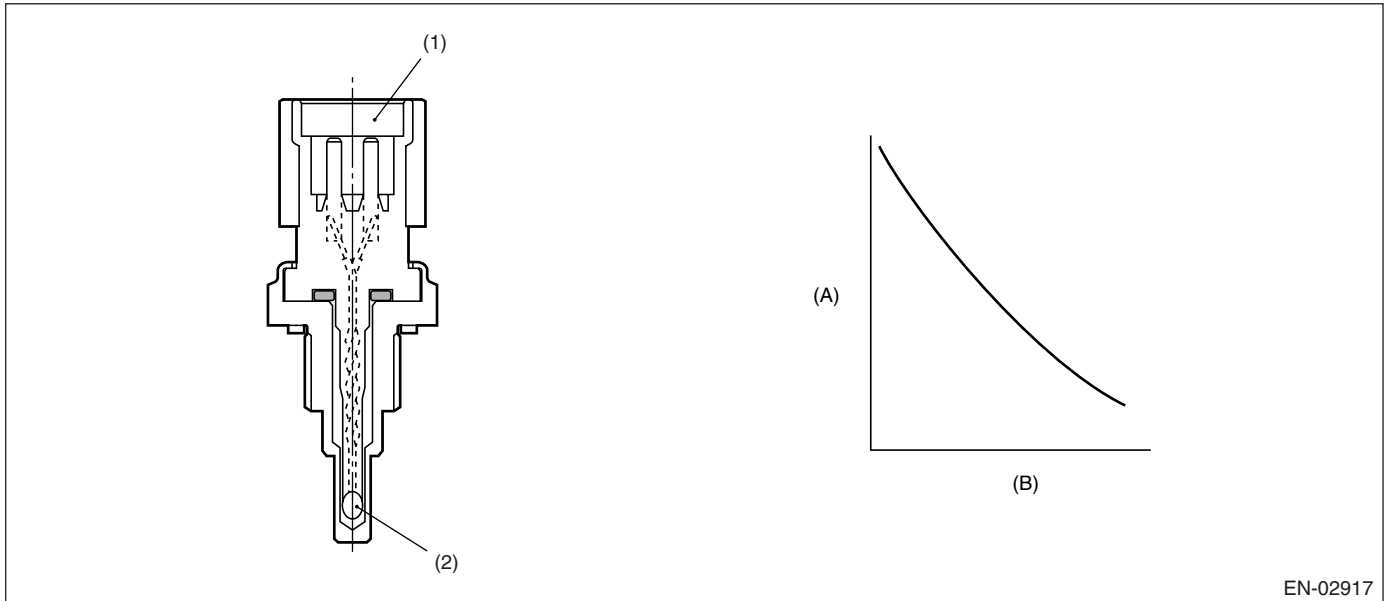

EN-02917

- (1) Connector
- (2) Thermistor element

- (A) Resistance value (k Ω)
- (B) Temperature °C (°F)

3. ENABLE CONDITION

Secondary Parameters	Enable Conditions
Battery voltage	≥ 10.9 V
Filling fuel from stopping engine at the previous time to starting it this time	No
Fuel level	≥ 15 ℓ (3.96 US gal, 3.3 Imp gal)
Engine coolant temperature when stopping engine at the previous time	$\geq 70^{\circ}\text{C}$ (158°F) and $< 95^{\circ}\text{C}$ (203°F)

4. GENERAL DRIVING CYCLE

Perform the diagnosis once after starting the engine.

Diagnostic Trouble Code (DTC) Detecting Criteria

GENERAL DESCRIPTION

5. DIAGNOSTIC METHOD

• Abnormality Judgment

Judge NG when the cumulative time of completing the malfunction criteria below becomes more than 2.5 seconds.

Judgment Value

Malfunction Criteria	Threshold Value
Engine coolant temperature when stopping engine at the previous time – The lowest engine coolant temperature after starting engine	< 2.5°C (36.5°F)
Fuel temperature when stopping engine at the previous time – Fuel temperature	≥ 5°C (41°F)
Intake air temperature – Fuel temperature	< 2.5°C (36.5°F)
Fuel temperature	< 35°C (95°F)

• Normality Judgment

Judge OK when the malfunction criteria below are completed.

Judgment Value

Malfunction Criteria	Threshold Value
Engine coolant temperature when stopping engine at the previous time – The lowest engine coolant temperature after starting engine	≥ 2.5°C (36.5°F)

Time Needed for Diagnosis: 2.5 seconds

Malfunction Indicator Light Illuminations: Detect when malfunction occurs in 2 continuous driving cycles.

6. DTC CLEAR CONDITION

- When the OK idling cycle is completed 40 times in a row
- When “Clear Memory” was performed

7. MALFUNCTION INDICATOR LIGHT CLEAR CONDITION

- When the OK idling cycle was completed 40 times in a row
- When “Clear Memory” was performed

8. FAIL SAFE

None

9. ECM OPERATION AT DTC SETTING

Memorize the freeze frame data. (For test mode \$02)

Diagnostic Trouble Code (DTC) Detecting Criteria

GENERAL DESCRIPTION

Y: DTC P0128 COOLANT THERMOSTAT (COOLANT TEMPERATURE BELOW THERMOSTAT REGULATING TEMPERATURE)

1. OUTLINE OF DIAGNOSIS

Detect the malfunction of thermostat function. Judge NG when the engine coolant temperature is lower than the estimated engine coolant temperature and the difference between them is large. Judge OK when the engine coolant temperature becomes 75°C (167°F) and the difference is small before judging NG.

2. COMPONENT DESCRIPTION

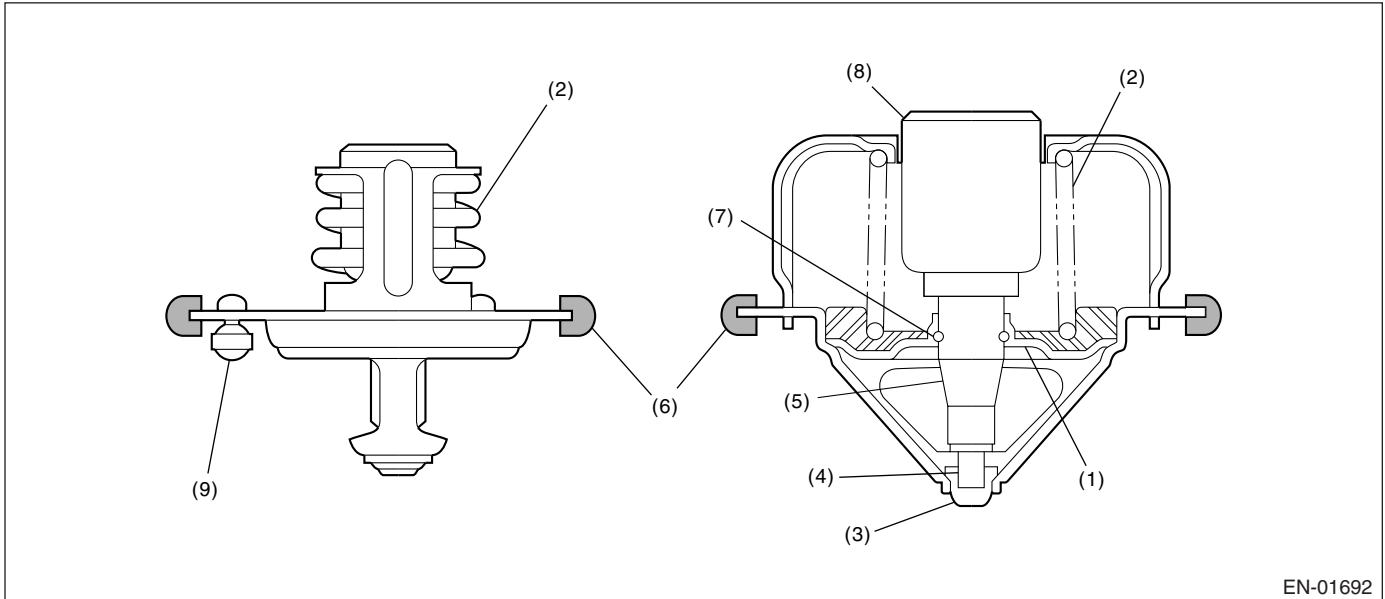

EN-01692

- | | |
|-------------|--------------------|
| (1) Valve | (6) Rubber packing |
| (2) Spring | (7) Stop ring |
| (3) Stopper | (8) Wax element |
| (4) Piston | (9) Jiggle valve |
| (5) Guide | |

3. ENABLE CONDITION

Secondary Parameters	Enable Conditions
None	

4. GENERAL DRIVING CYCLE

Always perform the diagnosis continuously.

Diagnostic Trouble Code (DTC) Detecting Criteria

GENERAL DESCRIPTION

5. DIAGNOSTIC METHOD

• Abnormality Judgment

Judge NG when the continuous time of completing the malfunction criteria below becomes more than 30 seconds.

Judgment Value

Malfunction Criteria	Threshold Value
Battery voltage	≥ 10.9 V
Estimated ambient air temperature	$\geq -7^{\circ}\text{C}$ (19°F)
Engine coolant temperature at engine starting	$< 55^{\circ}\text{C}$ (131°F)
Estimated engine coolant temperature	$\geq 70^{\circ}\text{C}$ (158°F)
Engine coolant temperature	$< 70^{\circ}\text{C}$ (158°F)
(Estimated – measured) engine coolant temperature	$> 30^{\circ}\text{C}$ (86°F)
Vehicle speed	≥ 30 km/h

Time Needed for Diagnosis: 30 seconds

Malfunction Indicator Light Illumination: Illuminates when malfunction occurs in 2 continuous driving cycles.

• Normality Judgment

Judge OK and clear the NG when the malfunction criteria below are completed.

Judgment Value

Malfunction Criteria	Threshold Value
Battery voltage	≥ 10.9 V
Estimated ambient air temperature	$\geq -7^{\circ}\text{C}$ (19°F)
Thermostat malfunction diagnosis	Not finished
Engine coolant temperature at engine starting	$< 55^{\circ}\text{C}$ (131°F)
Engine coolant temperature	$\geq 70^{\circ}\text{C}$ (158°F)
(Estimated – measured) engine coolant temperature	$\leq 30^{\circ}\text{C}$ (68°F)

6. DTC CLEAR CONDITION

- When the OK idling cycle was completed 40 times in a row
- When “Clear Memory” was performed

7. MALFUNCTION INDICATOR LIGHT CLEAR CONDITION

- When the OK driving cycle was completed 3 times in a row
- When “Clear Memory” was performed

8. FAIL SAFE

None

9. ECM OPERATION AT DTC SETTING

- Memorize the freeze frame data. (For test mode \$02)
- Memorize the diagnostic value and trouble standard value. (For test mode \$06)

Diagnostic Trouble Code (DTC) Detecting Criteria

GENERAL DESCRIPTION

Z: DTC P0131 O₂ SENSOR CIRCUIT LOW VOLTAGE (BANK 1 SENSOR 1)

1. OUTLINE OF DIAGNOSIS

Detect the open or short circuit of sensor.

Judge NG when the element impressed voltage is out of range, or the element current is out of range.

2. COMPONENT DESCRIPTION

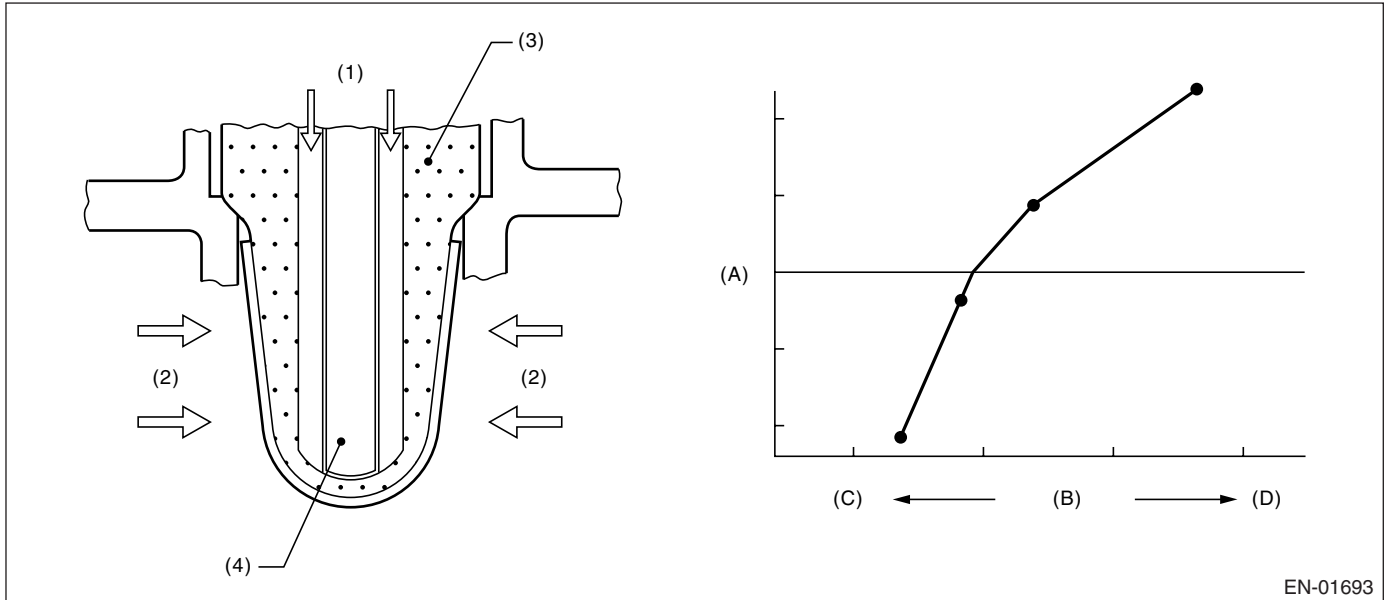

EN-01693

- | | |
|----------------------|-------------------------|
| (1) Atmosphere | (A) Electromotive force |
| (2) Exhaust | (B) Air fuel ratio |
| (3) ZrO ₂ | (C) Lean |
| (4) Ceramic heater | (D) Rich |

3. ENABLE CONDITION

Secondary Parameters	Enable Conditions
Voltage	≥ 10.9 V

4. GENERAL DRIVING CYCLE

Always perform the diagnosis continuously.

5. DIAGNOSTIC METHOD

Judge NG when the continuous time of completing any malfunction criteria below becomes more than 1 second.

Judgment Value

Malfunction Criteria	Threshold Value
Input voltage	< 1.8 V
Input current	< -0.01 A

Time Needed for Diagnosis: 1 second

Malfunction Indicator Light Illumination: Illuminates as soon as the malfunction occurs.

6. DTC CLEAR CONDITION

- When the OK idling cycle was completed 40 times in a row
- When "Clear Memory" was performed

Diagnostic Trouble Code (DTC) Detecting Criteria

GENERAL DESCRIPTION

7. MALFUNCTION INDICATOR LIGHT CLEAR CONDITION

- When the OK driving cycle was completed 3 times in a row
- When "Clear Memory" was performed

8. FAIL SAFE

- Front oxygen (A/F) sensor activation judgment: Front oxygen (A/F) sensor full activation is not complete, or front oxygen (A/F) sensor half activation is not complete.
- A/F main learning: Not allowed to calculate the A/F main learning compensation factor.
- Compensation when starting the engine at high temperature: Make the MIN value to be 0 from 0.3 normally.
- Purge control: Not allowed to purge.

9. ECM OPERATION AT DTC SETTING

Memorize the freeze frame data. (For test mode \$02)

Diagnostic Trouble Code (DTC) Detecting Criteria

GENERAL DESCRIPTION

AA:DTC P0132 O₂ SENSOR CIRCUIT HIGH VOLTAGE (BANK 1 SENSOR 1)

1. OUTLINE OF DIAGNOSIS

Detect the open or short circuit of sensor.

Judge NG when the element impressed voltage is out of range, or the element current is out of range.

2. COMPONENT DESCRIPTION

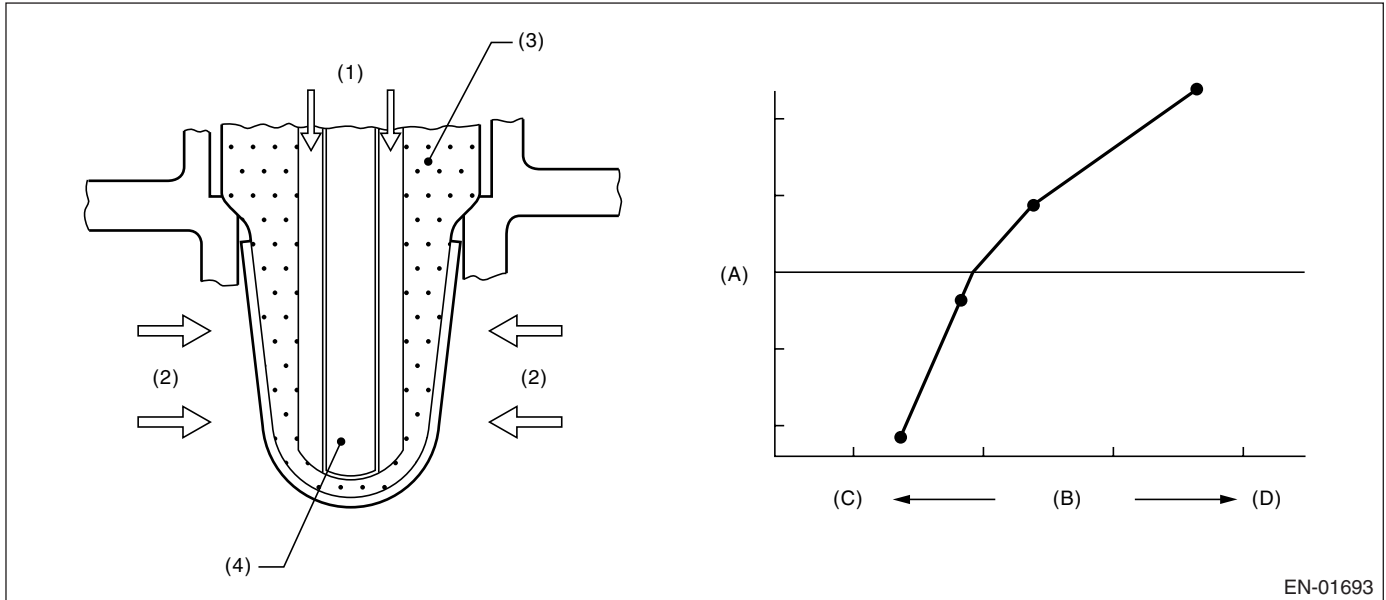

EN-01693

- | | |
|----------------------|-------------------------|
| (1) Atmosphere | (A) Electromotive force |
| (2) Exhaust | (B) Air fuel ratio |
| (3) ZrO ₂ | (C) Lean |
| (4) Ceramic heater | (D) Rich |

3. ENABLE CONDITION

Secondary Parameters	Enable Conditions
Voltage	≥ 10.9 V

4. GENERAL DRIVING CYCLE

Always perform the diagnosis continuously.

5. DIAGNOSTIC METHOD

Judge NG when the continuous time of completing any malfunction criteria below becomes more than 1 second.

Judgment Value

Malfunction Criteria	Threshold Value
Input voltage	≥ 3.8 V
Input current	≥ 0.01 A

Time Needed for Diagnosis: 1 second

Malfunction Indicator Light Illumination: Illuminates as soon as the malfunction occurs.

6. DTC CLEAR CONDITION

- When the OK idling cycle was completed 40 times in a row
- When "Clear Memory" was performed

Diagnostic Trouble Code (DTC) Detecting Criteria

GENERAL DESCRIPTION

7. MALFUNCTION INDICATOR LIGHT CLEAR CONDITION

- When the OK driving cycle was completed 3 times in a row
- When "Clear Memory" was performed

8. FAIL SAFE

- Front oxygen (A/F) sensor activation judgment: Front oxygen (A/F) sensor full activation is not complete, or front oxygen (A/F) sensor half activation is not complete.
- A/F main learning: Not allowed to calculate the A/F main learning compensation factor.
- Compensation when starting the engine at high temperature: Make the MIN value to be 0 from 0.3 normally.
- Purge control: Not allowed to purge.

9. ECM OPERATION AT DTC SETTING

Memorize the freeze frame data. (For test mode \$02)

AB:DTC P0133 O₂ SENSOR CIRCUIT SLOW RESPONSE (BANK 1 SENSOR 1)

1. OUTLINE OF DIAGNOSIS

Detect time-lag of front oxygen (A/F) sensor response. Front oxygen (A/F) sensor cover has some ventilation holes for exhaust gas. Clogged ventilation holes are diagnosed. When the holes are clogged, the A/F output variation becomes slow comparing with the actual A/F variation because oxygen which reaches the zirconia layer is insufficient. Therefore, if the cover has clogged holes, the rich to lean judgment in ECM is delayed when the change from rich to lean is caused. Judge NG when the actual A/F variation is slow comparing with the ECM control amount.

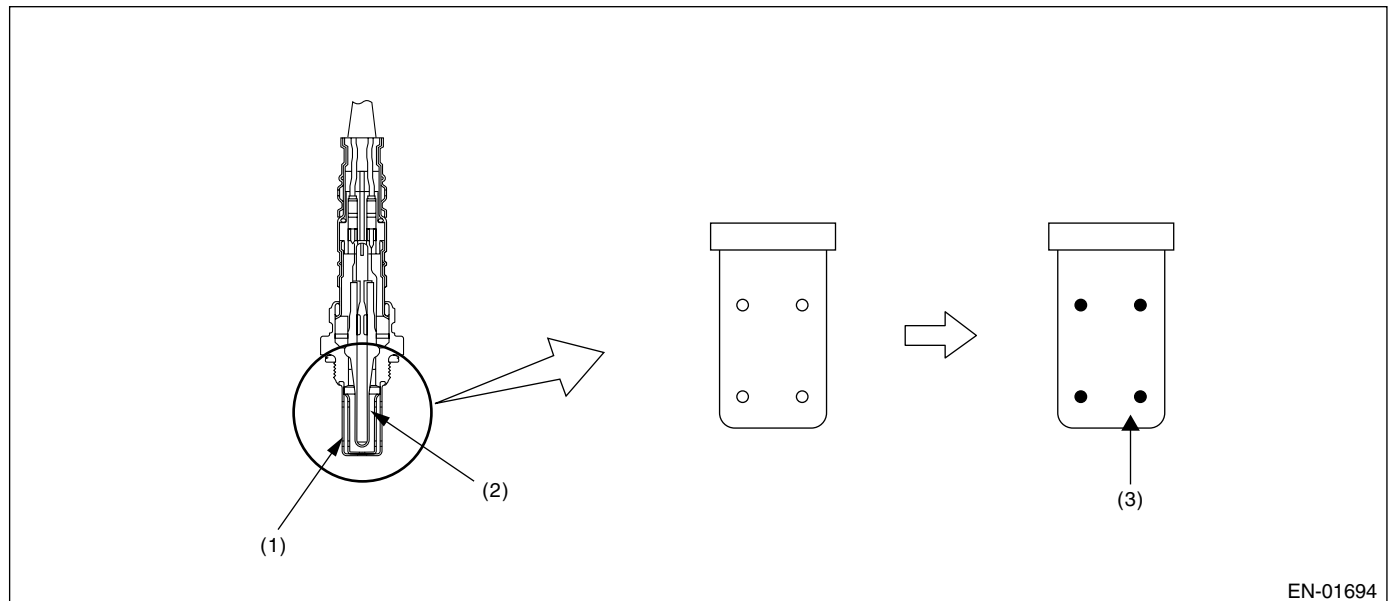

- (1) Cover
- (2) Zirconia
- (3) Clogging

EN-01694

Diagnostic Trouble Code (DTC) Detecting Criteria

GENERAL DESCRIPTION

2. COMPONENT DESCRIPTION

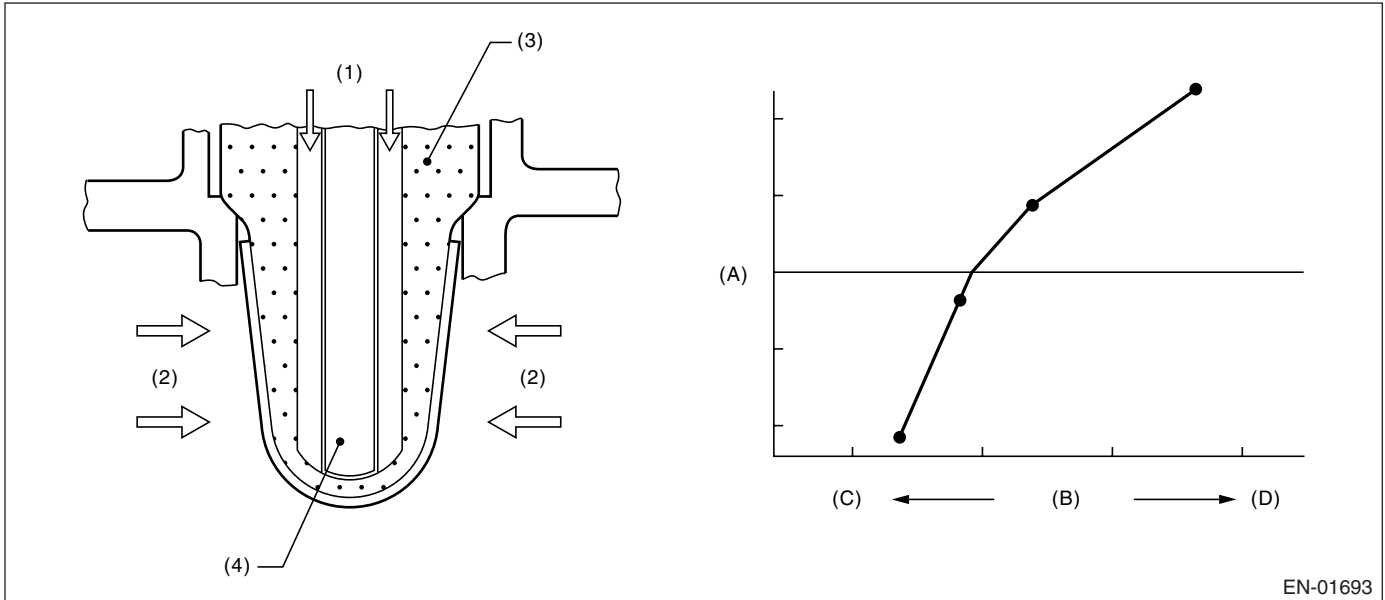

- (1) Atmosphere
- (2) Exhaust
- (3) ZrO_2
- (4) Ceramic heater

- (A) Electromotive force
- (B) Air fuel ratio
- (C) Lean
- (D) Rich

3. ENABLE CONDITION

Secondary Parameters	Enable Conditions
Time needed for all secondary parameters in enable conditions	≥ 1 second
Battery voltage	> 10.9 V
Atmospheric pressure	> 75.0 kPa (563 mmHg, 22.2 inHg)
Closed loop control with main feedback	operating
Impedance of front oxygen (A/F) sensor	$0 \leftrightarrow 50 \Omega$
After engine starting	120 seconds or more
Engine coolant temperature	$\geq 70^\circ\text{C}$ (158°F)
Engine speed	$1,000 \leftrightarrow 3,200$ rpm
Vehicle speed	$10 \leftrightarrow 120$ km/h (6 \leftrightarrow 75 MPH)
Amount of intake air	$10 \leftrightarrow 31$ g/s
Engine load change during 0.5 engine rev.	≤ 0.02 g/rev
Learning value of EVAP conc. during purge	≤ 0.2
Accumulated time of operating canister purge	20 seconds or more

4. GENERAL DRIVING CYCLE

Perform diagnosis only once at a constant speed of 10 to 120 km/h (6 to 75 MPH) in 120 seconds after starting the engine.

Diagnostic Trouble Code (DTC) Detecting Criteria

GENERAL DESCRIPTION

5. DIAGNOSTIC METHOD

Integrate the difference of f_{af} in every 128 milliseconds and difference of λ value.

After integrate 1,640 times (210 seconds), calculate the diagnosis value.

Judge NG when the malfunction criteria below are completed. Judge OK and clear NG when the malfunction criteria below are not completed.

Judgment Value

Malfunction Criteria	Threshold Value
$para_{fca} = td2f_{af}/td2l_{md}$ where, $td2f_{af}(N) = td2f_{af}(n-1) + d2f_{af}(n) $ $td2l_{md}(N) = td2l_{md}(n-1) + d2l_{md}(n) $ add up for a total of 210 seconds $d2f_{af}(n) = (f_{af}(n) - f_{af}(n-1)) - (f_{af}(n-1) - f_{af}(n-2))$ $d2l_{md}(n) = (l_{md}(n) - l_{md}(n-1)) - (l_{md}(n-1) - l_{md}(n-2))$ f_{af} = main feedback compensation coefficient every 128 milliseconds l_{md} = output lambda every 128 milliseconds	≥ 0.392

Time Needed for Diagnosis: 210 seconds

Malfunction Indicator Light Illumination: Illuminates when malfunction occurs in 2 continuous driving cycles.

6. DTC CLEAR CONDITION

- When the OK idling cycle was completed 40 times in a row
- When "Clear Memory" was performed

7. MALFUNCTION INDICATOR LIGHT CLEAR CONDITION

- When the OK driving cycle was completed 3 times in a row
- When "Clear Memory" was performed

8. FAIL SAFE

- Front oxygen (A/F) sensor main learning correction: Not allowed to calculate.
- Correction when re-starting at high temperature: Normally minimum value 0.3 \rightarrow 0.
- Purge control: Not allowed to purge.

9. ECM OPERATION AT DTC SETTING

- Memorize the freeze frame data. (For test mode \$02)
- Memorize the diagnostic value and trouble standard value. (For test mode \$06)

Diagnostic Trouble Code (DTC) Detecting Criteria

GENERAL DESCRIPTION

AC:DTC P0134 O₂ SENSOR CIRCUIT NO ACTIVITY DETECTED (BANK 1 SENSOR 1)

1. OUTLINE OF DIAGNOSIS

Detect the open circuit of sensor.

Judge NG when the element impedance is large.

2. COMPONENT DESCRIPTION

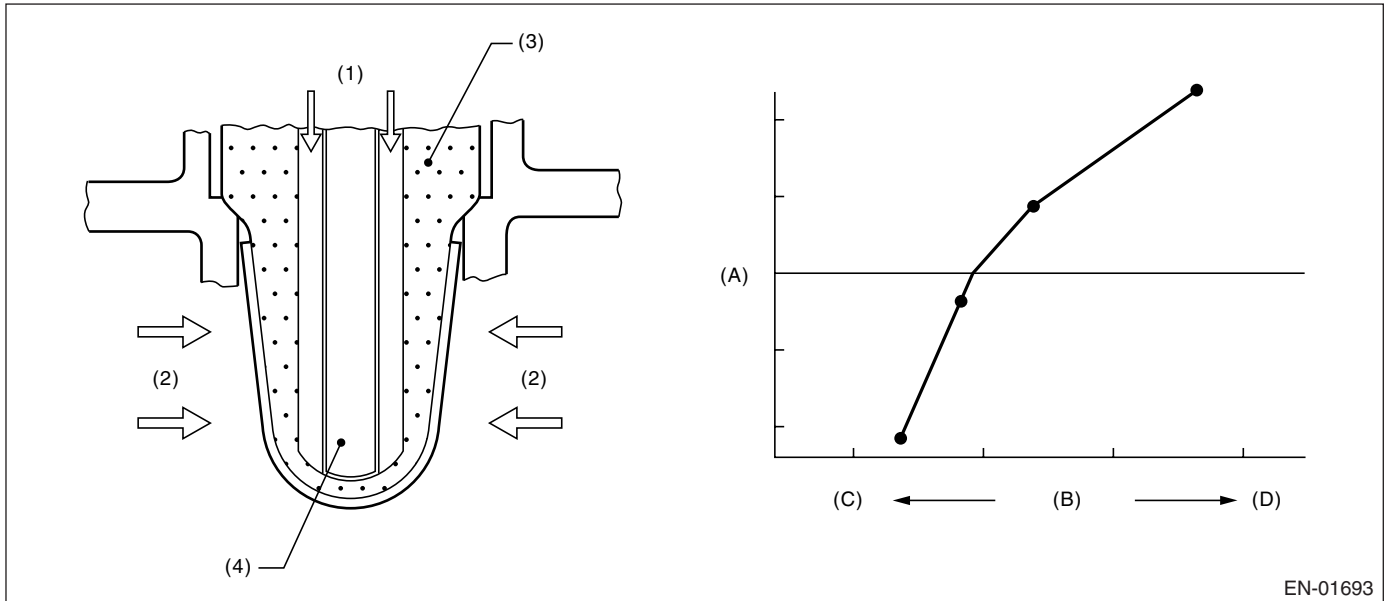

- (1) Atmosphere
- (2) Exhaust
- (3) ZrO₂
- (4) Ceramic heater

- (A) Electromotive force
- (B) Air fuel ratio
- (C) Lean
- (D) Rich

EN-01693

3. ENABLE CONDITION

Secondary Parameters	Enable Conditions
None	

4. GENERAL DRIVING CYCLE

Always perform the diagnosis continuously.

5. DIAGNOSTIC METHOD

Judge NG when the continuous time of completing the malfunction criteria below becomes more than 5 seconds.

Judgment Value

Malfunction Criteria	Threshold Value
Voltage	≥ 10.9 V
Time after engine starting	≥ 50 seconds
Cumulative amount of Front oxygen (A/F) sensor heater control duty every 128 milliseconds	≥ 28,000%
Front lambda sensor impedance	≥ 500 Ω

Time Needed for Diagnosis: 5 seconds

Malfunction Indicator Light Illumination: Illuminates as soon as the malfunction occurs.

Diagnostic Trouble Code (DTC) Detecting Criteria

GENERAL DESCRIPTION

6. DTC CLEAR CONDITION

- When the OK idling cycle was completed 40 times in a row
- When "Clear Memory" was performed

7. MALFUNCTION INDICATOR LIGHT CLEAR CONDITION

- When the OK driving cycle was completed 3 times in a row
- When "Clear Memory" was performed

8. FAIL SAFE

- Front oxygen (A/F) sensor activation judgment: Front oxygen (A/F) sensor full activation is not complete, or front oxygen (A/F) sensor half activation is not complete.
- Front oxygen sensor main learning correction: Not allowed to calculate.
- Compensation when starting the engine at high temperature: Make the MIN value to be 0 from 0.3 normally.
- Purge control: Not allowed to purge

9. ECM OPERATION AT DTC SETTING

Memorize the freeze frame data. (For test mode \$02)

AD:DTC P0137 O₂ SENSOR CIRCUIT LOW VOLTAGE (BANK 1 SENSOR 2)

1. OUTLINE OF DIAGNOSIS

Detect the malfunction of oxygen sensor power distribution NG. Judge NG when the oxygen sensor voltage is abnormal with considering the operating conditions.

2. COMPONENT DESCRIPTION

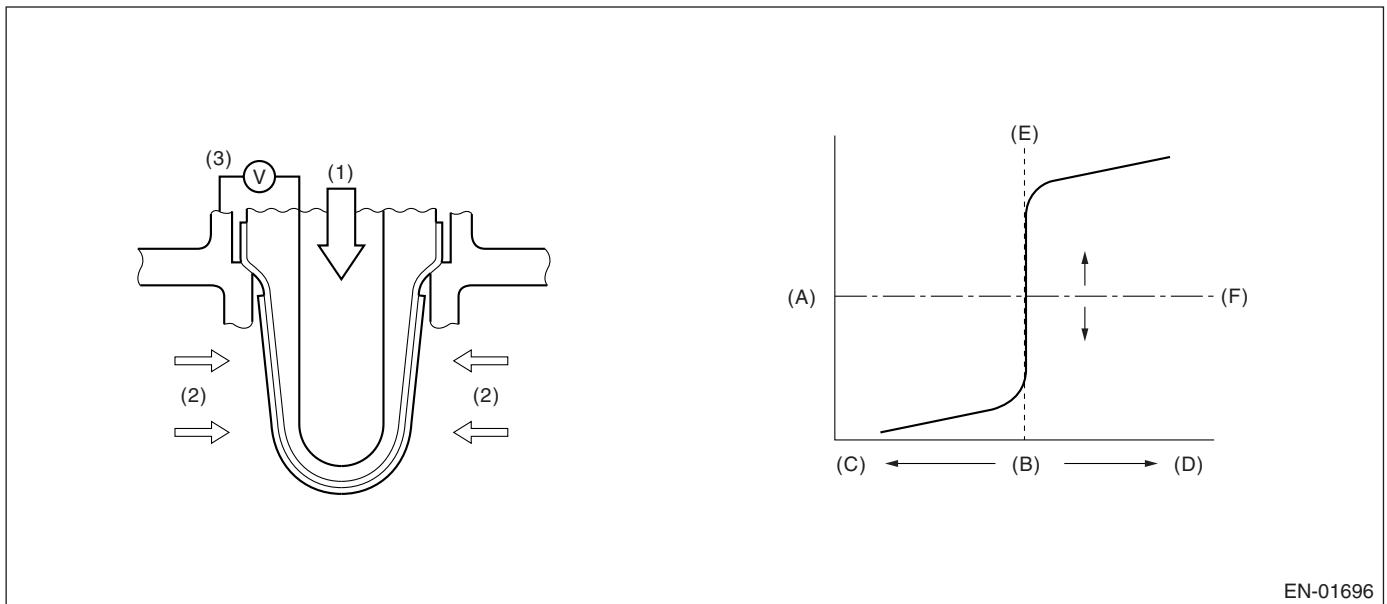

- (1) Atmosphere
- (2) Exhaust
- (3) Electromotive force

- (A) Electromotive force
- (B) Air fuel ratio
- (C) Rich
- (D) Lean
- (E) Theoretical air fuel ratio
- (F) Comparative voltage

Diagnostic Trouble Code (DTC) Detecting Criteria

GENERAL DESCRIPTION

3. ENABLE CONDITION (USED ONLY FOR MALFUNCTION JUDGMENT)

Abnormality Judgement

Secondary Parameters	Enable Conditions
High side	
Secondary air system	Not in operation
Closed loop control of oxygen sensor	In operation
Misfire detection during 200 engine revs.	< 5 times
Compensation factor for front oxygen (A/F) sensor	Not in limit value
Battery voltage	> 10.9 V
Low side 1	
Secondary air system	Not in operation
Closed loop control of oxygen sensor	In operation
Misfire detection during 200 engine revs.	< 5 times
Compensation factor for front oxygen (A/F) sensor	Not in limit value
Battery voltage	> 10.9 V
Amount of intake air	≥ 10 g (0.35 oz)/s
Low side 2	
Secondary air system	Not in operation
Closed loop control of oxygen sensor	In operation
Misfire detection during 200 engine revs.	< 5 times
Compensation factor for front oxygen (A/F) sensor	Not in limit value
Battery voltage	> 10.9 V
Amount of intake air	< 10 g (0.35 oz)/s
Continuous time of rear oxygen heater current	25 seconds or more
Low side 3	
Secondary air system	Not in operation
Closed loop control of oxygen sensor	In operation
Misfire detection during 200 engine revs.	< 5 times
Compensation factor for front oxygen (A/F) sensor	Not in limit value
Battery voltage	> 10.9 V
Amount of intake air	< 10 g (0.35 oz)/s
Continuous time of rear oxygen heater current	25 seconds or more
Fuel cut	Experienced

Normality Judgement

Secondary Parameters	Enable conditions
Secondary air system	No operation
Closed loop control of oxygen sensor	In operation
Misfire detection during 200 engine revs.	< 5 times
Compensation factor for front oxygen (A/F) sensor	Not in limit value
Battery voltage	> 10.9 V

4. GENERAL DRIVING CYCLE

Perform the diagnosis continuously after starting the engine at engine steady operation condition.

Diagnostic Trouble Code (DTC) Detecting Criteria

GENERAL DESCRIPTION

5. DIAGNOSTIC METHOD

• Abnormality Judgment

Judge NG when the continuous time of completing the malfunction criteria below becomes more than the time needed for diagnosis. Judge OK when the malfunction criteria below are not completed.

Judgment Value

Malfunction Criteria	Threshold Value	DTC
High side Max. output voltage without continuity	$\geq 1,200$ mV	P0138
Low side Min. output voltage without continuity	< 30 mV	P0137

Time Needed for Diagnosis:

High side: 2.5 seconds

Low side 1: 20 seconds

Low side 2: 40 seconds

Low side 3: Value of Map

Map

Fuel shut-off time (sec.)	Time Needed for Diagnosis (sec.)
0	40
2	40
10	60

Malfunction Indicator Light Illumination: Illuminates when malfunction occurs in 2 continuous driving cycles.

6. DTC CLEAR CONDITION

- When the OK idling cycle was completed 40 times in a row
- When "Clear Memory" was performed

7. MALFUNCTION INDICATOR LIGHT CLEAR CONDITION

- When the OK driving cycle was completed 3 times in a row
- When "Clear Memory" was performed

8. FAIL SAFE

Sub feedback control: Not allowed

9. ECM OPERATION AT DTC SETTING

Memorize the freeze frame data. (For test mode \$02)

AE:DTC P0138 O₂ SENSOR CIRCUIT HIGH VOLTAGE (BANK 1 SENSOR 2)

NOTE:

For the detecting criteria, refer to DTC P0137. <Ref. to GD(H4DOTC)-62, DTC P0137 O₂ SENSOR CIRCUIT LOW VOLTAGE (BANK 1 SENSOR 2), Diagnostic Trouble Code (DTC) Detecting Criteria.>

AF:DTC P0139 O₂ SENSOR CIRCUIT SLOW RESPONSE (BANK 1 SENSOR 2)

1. OUTLINE OF DIAGNOSIS

Detect the slow response of rear oxygen sensor.

Judge NG when the Rich → Lean response diagnosis or Lean → Rich response diagnosis is NG and judge OK when both response diagnoses are OK.

[Rich → Lean diagnosis response]

(1) When the measured response time is larger than a threshold, since the A/F ratio is rich, the response time of the output change of O₂ sensor when changing from Rich to Lean is measured, and it judges with NG, and when small, it judges with OK.

(2) When O₂ sensor voltage at the time of a fuel shut-off in deceleration return is large (rich), it judges with NG.

[Lean → Rich diagnosis response]

(1) The response time of output change of O₂ sensor when an A/F ratio changes from Lean to Rich is measured, and it is referred to as NG when the measured response time is larger than a threshold.

(2) It is referred to as NG when O₂ sensor voltage after recovery of fuel shut-off in deceleration is small and still small.

Diagnostic Method

Measure the response time of the output change of the oxygen sensor when the A/F ratio changes from rich to lean. And Judge NG when the measured response time is larger than the threshold value.

2. COMPONENT DESCRIPTION

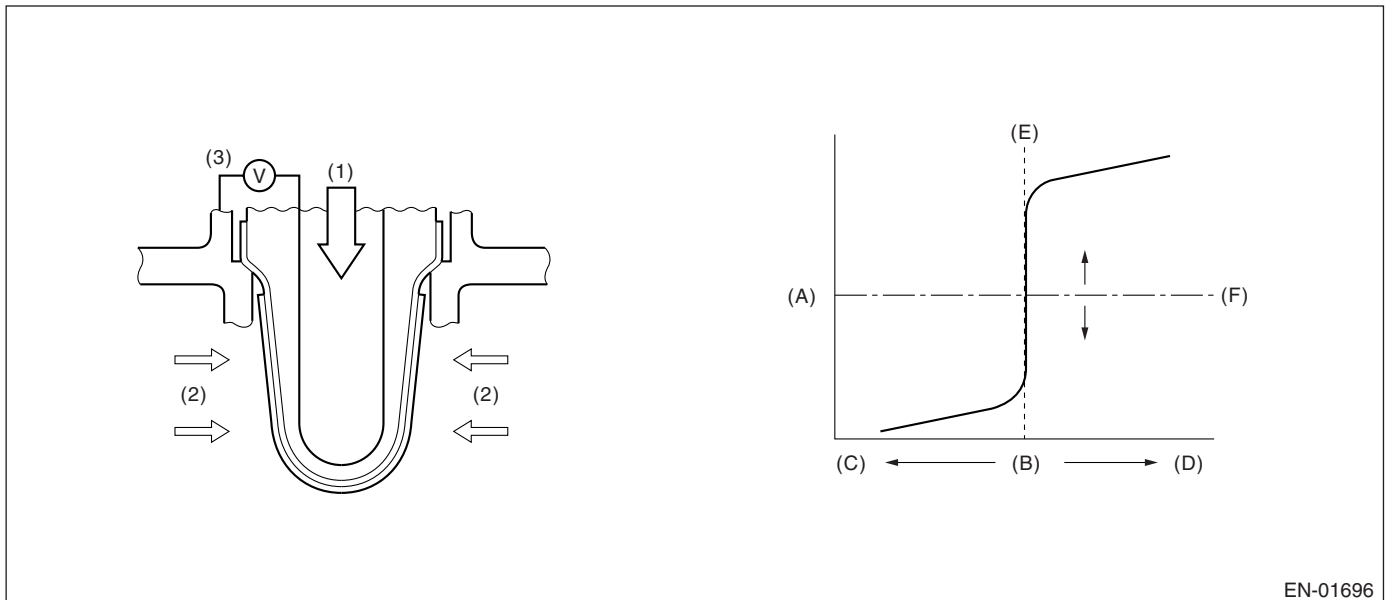

EN-01696

- (1) Atmosphere
- (2) Exhaust
- (3) Electromotive force

- (A) Electromotive force
- (B) Air fuel ratio
- (C) Rich
- (D) Lean
- (E) Theoretical air fuel ratio
- (F) Comparative voltage

Diagnostic Trouble Code (DTC) Detecting Criteria

GENERAL DESCRIPTION

3. ENABLE CONDITION

Secondary Parameters	Enable Conditions
Battery voltage	> 10.9 V
A/F sub feedback control condition	Completed
5 seconds or more fuel shut-off in deceleration	Experienced
After fuel cut	≥ 2 seconds
Cumulative time for current conducted in rear oxygen sensor	≥ 60 s
Continuous time for current conducted in rear oxygen sensor	≥ 30 s
Catalyst warm-up counter	≥ 7,000 times

4. GENERAL DRIVING CYCLE

Perform the diagnosis only once when fuel shut-off in deceleration after rapid acceleration in order to calculate the diagnostic value. (Pay attention to oxygen sensor voltage for the timing of deceleration.)

Diagnostic Trouble Code (DTC) Detecting Criteria

GENERAL DESCRIPTION

5. DIAGNOSTIC METHOD

When the rear oxygen sensor output voltage changes from 0.55 V (rich) to 0.25 V (lean), calculate the Min. value of response time regarded as judgment value while the output varies from 0.5 V to 0.3 V.

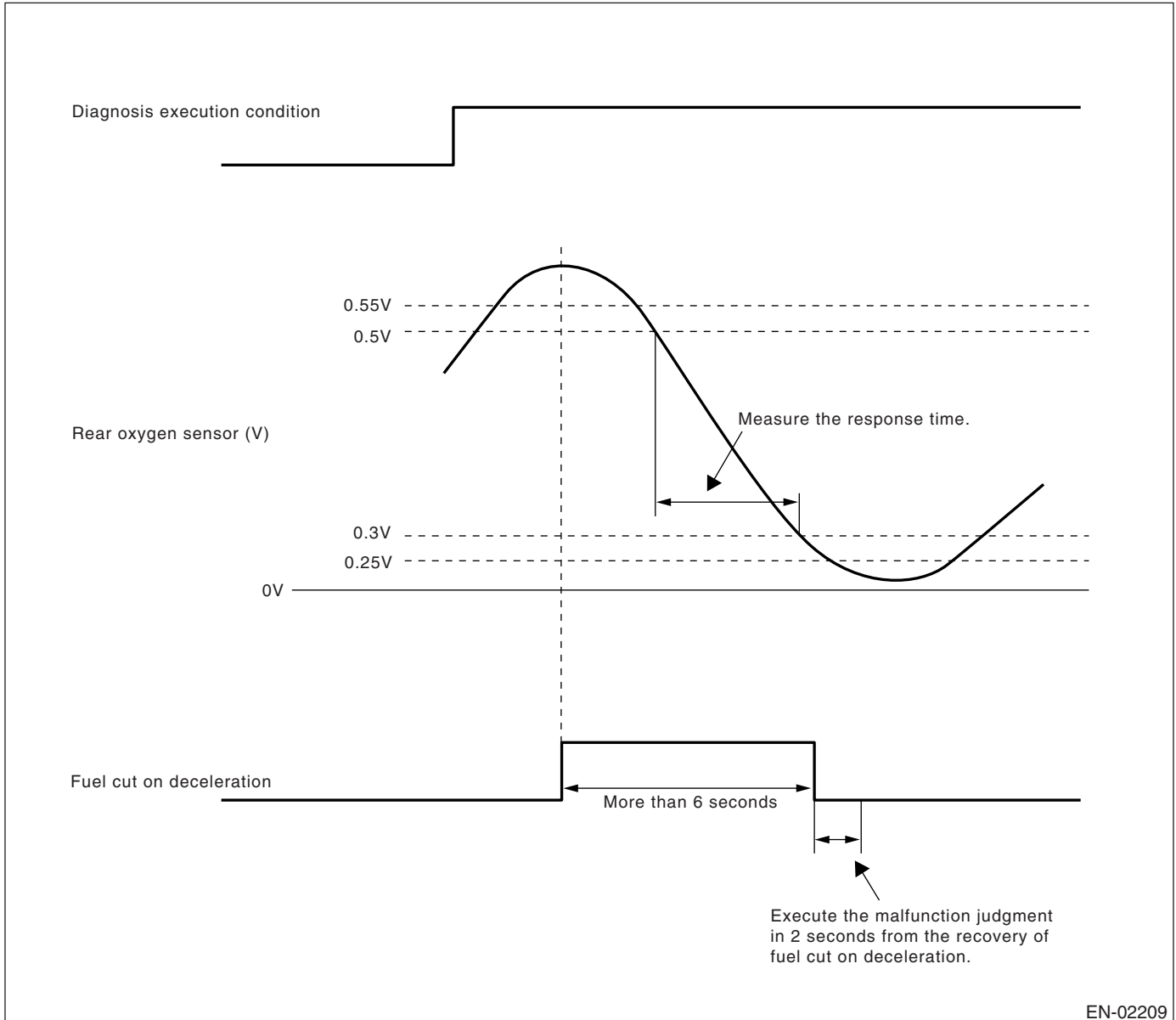

• Abnormality Judgment

(1) Judge NG when the judgment value is larger than the threshold value after fuel shut-off in deceleration. Response time (Diagnosis value) > Threshold value → Abnormal

NOTE:

Variation time of rear oxygen sensor output voltage is short during fuel shut-off in deceleration. Carry out the NG judgment only after the fuel shut-off in deceleration. As for OK judgment, without the condition of fuel shut-off in deceleration, judge OK if the value is below the threshold value.

Judge NG when the malfunction criteria below are completed in 2 seconds after the recovery of fuel shut-off in deceleration which requires 6 seconds or more.

(2) Judge NG when the O₂ sensor voltage after recovery of fuel shut-off in deceleration is large. Judge NG when fuel shut-off in deceleration is also long (6 sec. or more), and although carried out the fuel shut-off in deceleration cut return, when O₂ sensor voltage is large (more than 0.55V).

Diagnostic Trouble Code (DTC) Detecting Criteria

GENERAL DESCRIPTION

Judgment Value

Malfunction Criteria	Threshold Value
Shortest time change from rich (500 mV O ₂ output) to lean (300 mV) if voltage reduces from 550 mV to 250 mV.	> 0.327 seconds
Time when more than 550 mV	> 2 seconds

Time Needed for Diagnosis: Once

Malfunction Indicator Light Illumination: Illuminates when malfunction occurs in 2 continuous driving cycles.

• Normality Judgement

(1) Judge Normal when the response time (diagnostic value) is smaller than threshold (judgment value) when changing to lean since O₂ sensor voltage.

(2) A normal judging is not carried out.

Judge OK when the following standards value are completed.

Judgment Value

Malfunction Criteria	Threshold Value
Change of the shortest time from rich (500 mV O ₂ output), when voltage decreases from 550 mV to 250 mV to lean (300 mV).	≤ 0.327 seconds

6. DTC CLEAR CONDITION

- When the OK idling cycle was completed 40 times in a row
- When "Clear Memory" was performed

7. MALFUNCTION INDICATOR LIGHT CLEAR CONDITION

- When the OK driving cycle was completed 3 times in a row
- When "Clear Memory" was performed

8. FAIL SAFE

Sub feedback control: Not allowed

9. ECM OPERATION AT DTC SETTING

- Memorize the freeze frame data. (For test mode \$02)
- Memorize the diagnostic value and trouble standard value. (For test mode \$06)

10.ENABLE CONDITION

- Lean → Rich response diagnosis

Secondary Parameters	Enable Conditions
Battery voltage	> 10.9 V
A/F main feedback control condition	Completed
Fuel cut on deceleration ≥ 5 seconds	Experienced
After fuel cut	≥ 2 seconds
Accumulative time of rear oxygen sensor heater energization	≥ 60 seconds
Continuous time of rear oxygen sensor heater energization	≥ 30 seconds

11.GENERAL DRIVING CYCLE

Perform the diagnosis only once when fuel shut-off in deceleration after rapid acceleration. (Pay attention to oxygen sensor voltage for the timing of deceleration.)

Diagnostic Trouble Code (DTC) Detecting Criteria

GENERAL DESCRIPTION

12. DIAGNOSTIC METHOD

When the oxygen sensor output voltage changes from 0.25 V (lean) to 0.55 V (rich), calculate the Min. value of response time regarded as judgment value while the output varies from 0.3 V to 0.5 V.

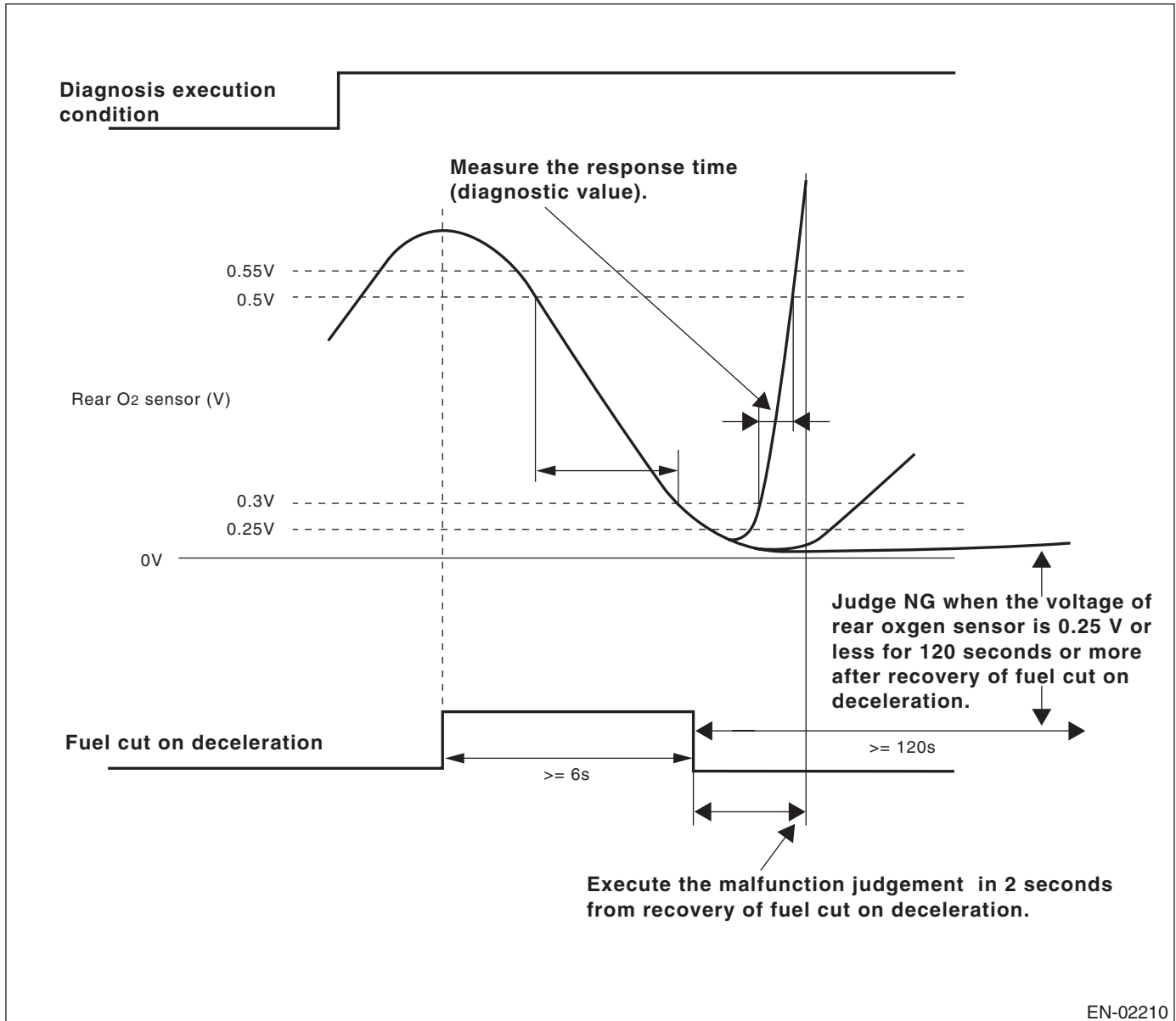

• Abnormality Judgment

(1) Judge NG when the judgment value is larger than the threshold value after recovery of fuel shut-off in deceleration.

Response time (Diagnosis value) > Threshold value → Abnormal

(2) Judge NG when the O₂ sensor voltage after recovery of fuel shut-off in deceleration is small.

Judgment Value

Malfunction Criteria	Threshold Value
Shortest time change from lean (300 mV O ₂ output) to rich (500 mV) if voltage reduces from 500 mV to 250 mV.	> 2 seconds
Or longest time to change to 250 mV	> 120 seconds

Time Needed for Diagnosis: Once

Malfunction Indicator Light Illumination: Illuminates when malfunction occurs in 2 continuous driving cycles.

Diagnostic Trouble Code (DTC) Detecting Criteria

GENERAL DESCRIPTION

• Normality Judgement

(1) Judge Normal when the response time (diagnostic value) is smaller than threshold (judgment value) when changing to lean since O₂ sensor voltage.

Response Time (diagnosis value) ≤ Threshold value → Normal

(2) A normal judging is not carried out.

Judgment Value

Judge OK when the following standards value are completed.

Malfunction Criteria	Threshold Value
Change of the shortest time from rich (300 mV O ₂ output), when voltage decreases from 550 mV to 250 mV to lean (500 mV).	≤ 2 seconds

13.DTC CLEAR CONDITION

- When the OK idling cycle was completed 40 times in a row
- When “Clear Memory” was performed

14.MALFUNCTION INDICATOR LIGHT CLEAR CONDITION

- When the OK driving cycle was completed 3 times in a row
- When “Clear Memory” was performed

15.FAIL SAFE

Sub feedback control: Not allowed

16.ECM OPERATION AT DTC SETTING

- Memorize the freeze frame data. (For test mode \$02)
- Memorize the diagnostic value and trouble standard value. (For test mode \$06)

Diagnostic Trouble Code (DTC) Detecting Criteria

GENERAL DESCRIPTION

AG:DTC P0140 O₂ SENSOR CIRCUIT NO ACTIVITY DETECTED (BANK 1 SENSOR 2)

1. OUTLINE OF DIAGNOSIS

Detect the malfunction of rear oxygen sensor output property.

Judge Low side NG when the rear oxygen sensor voltage indicates low, otherwise, judge High side NG when the rear oxygen sensor voltage indicates high, in spite of the driving condition that the voltage might move, by referring to the driving condition such as amount of intake air, coolant temperature, main feedback control, fuel shut-off in deceleration, etc.

Judge rear oxygen sensor property NG when the Low side or High side becomes NG.

2. ENABLE CONDITION

Secondary Parameters	Enable Conditions
Engine coolant temperature	≥ 70°C (158°F)
Target output voltage of rear oxygen sensor	≥ 0.6 V
Amount of intake air	10 g (0.35 oz)/sec. or more
Battery voltage	> 10.9 V
Closed loop with oxygen sensor	In operation
Misfire detection during 200 engine revs.	5 times or less
Compensation factor for front oxygen (A/F) sensor	Not in limit value
5 seconds or more fuel shut-off in decel.	Experienced

3. GENERAL DRIVING CYCLE

Perform the diagnosis once after warming-up the engine.

4. DIAGNOSTIC METHOD

• Abnormality Judgment

Judge NG when the malfunction criteria below are completed.

Judgment Value

Malfunction Criteria	Threshold Value
Low side of max. output voltage	< 550 mV
High side of min. output voltage	> 250 mV

Time Needed for Diagnosis: 200 seconds

Malfunction Indicator Light Illumination: Illuminates when malfunction occurs in 2 continuous driving cycles.

• Normality Judgment

Judge OK when the malfunction criteria below are completed.

Judgment Value

Malfunction Criteria	Threshold Value
Low side of max. output voltage	≥ 550 mV
High side of min. output voltage	≤ 250 mV

5. DTC CLEAR CONDITION

- When the OK idling cycle was completed 40 times in a row
- When "Clear Memory" was performed

6. MALFUNCTION INDICATOR LIGHT CLEAR CONDITION

- When the OK driving cycle was completed 3 times in a row
- When "Clear Memory" was performed

Diagnostic Trouble Code (DTC) Detecting Criteria

GENERAL DESCRIPTION

7. FAIL SAFE

None

8. ECM OPERATION AT DTC SETTING

- Memorize the freeze frame data. (For test mode \$02)
- Memorize the diagnostic value and trouble standard value. (For test mode \$06)

AH:DTC P0171 SYSTEM TOO LEAN (BANK 1)

1. OUTLINE OF DIAGNOSIS

Detect the fuel system malfunction by the amount of main feedback control.

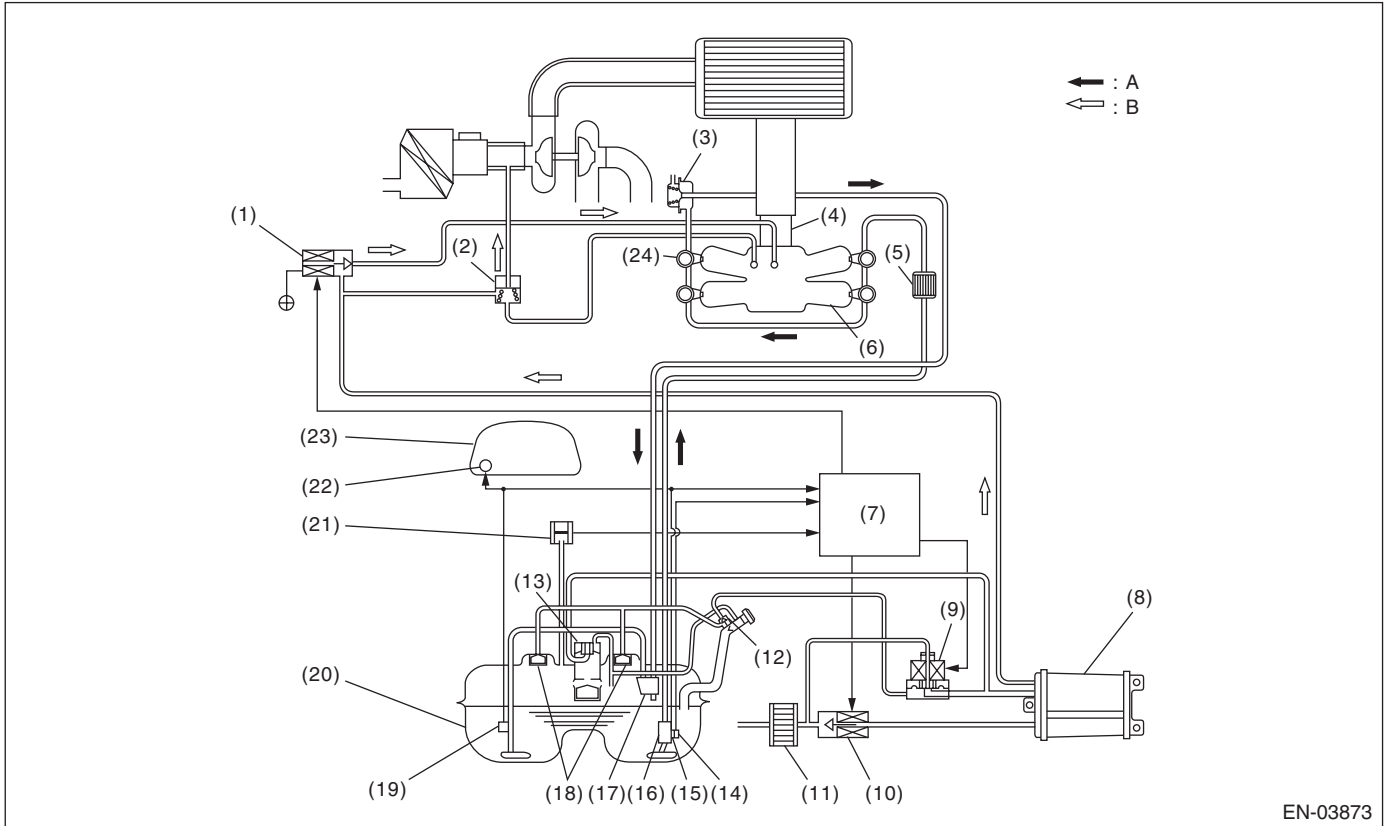

EN-03873

- | | | |
|-------------------------------------|------------------------------|--------------------------------|
| (1) Purge control solenoid valve | (10) Drain valve | (19) Fuel sub level sensor |
| (2) Purge valve | (11) Drain filter | (20) Fuel tank |
| (3) Pressure regulator | (12) Shut-off valve | (21) Fuel tank pressure sensor |
| (4) Throttle body | (13) Vent valve | (22) Fuel gauge |
| (5) Fuel filter | (14) Fuel temperature sensor | (23) Combination meter |
| (6) Intake manifold | (15) Fuel level sensor | (24) Fuel injector |
| (7) Engine control module (ECM) | (16) Fuel pump | (A) Fuel line |
| (8) Canister | (17) Jet pump | (B) Evaporation fuel line |
| (9) Pressure control solenoid valve | (18) Fuel cut valve | |

• Diagnostic Method

Fuel system is diagnosed by comparing the target air fuel ratio calculated by ECM with the actual air fuel ratio measured by sensor.

Diagnostic Trouble Code (DTC) Detecting Criteria

GENERAL DESCRIPTION

2. ENABLE CONDITION

Secondary Parameters	Enable Conditions
A/F main learning system	In operation
Engine coolant temperature	≥ 70°C (158°F)
Engine load	≥ Value of Map 5
Intake air change during 0.5 engine rev.	≤ 0.02 g/rev

Map 5

Engine speed (rpm)	Idle	800	1,200	1,600	2,000	2,400	2,800	3,200	3,600	4,000	4,400
Measured value (g (oz)/rev)	Non-turbo	0.228 (0.008)	0.22 (0.0078)	0.22 (0.0078)	0.22 (0.0078)	0.228 (0.008)	0.23 (0.0081)	0.234 (0.0083)	0.242 (0.0085)	0.250 (0.0088)	0.250 (0.0088)

3. GENERAL DRIVING CYCLE

Perform the diagnosis continuously at engine idle or constant vehicle speed after warm-up.

4. DIAGNOSTIC METHOD

• Abnormality Judgment

Judge that the fuel system malfunction occurs when the time during completing the malfunction criteria below continues 50 seconds or more by comparing the diagnosed value (fsobd) with threshold value.

Judgment Value

Malfunction Criteria	Threshold Value
$fsobd = (sglmd - tglmda) + faf + flaf$ where, sglmd = measured lambda tglmda = target lambda faf = main feedback compensation coefficient every 64 milliseconds flaf = main feedback learning compensation coefficient	≥ fsobdL1 See Map 4 fsobdL1 = lean side threshold value of fsobd

Map 4 Threshold value for fuel system malfunction criteria

Amount of air (g (oz)/s)	0	2.4 (0.085)	4.7 (0.166)	7 (0.247)	9.4 (0.332)	11.7 (0.413)	14.1 (0.497)
fsobdL1 (%)	40	40	36.9	32.0	27.0	26.5	26.5

Time Needed for Diagnosis: 10 seconds × 5 times

Malfunction Indicator Light Illumination: Illuminates when malfunction occurs in 2 continuous driving cycles.

• Normality Judgment

Judge OK when the malfunction criteria below are continued for 10 seconds.

Judgment Value

Malfunction Criteria	Threshold Value
$fsobd = (sglmd - tglmda) + faf + flaf$	< 19%

5. DTC CLEAR CONDITION

- When the OK idling cycle was completed 40 times in a row
- When "Clear Memory" was performed

6. MALFUNCTION INDICATOR LIGHT CLEAR CONDITION

- When OK with similar drive in 3 driving cycles.
- When "Clear Memory" was performed

Diagnostic Trouble Code (DTC) Detecting Criteria

GENERAL DESCRIPTION

7. FAIL SAFE

Rich side malfunction

- Purge control solenoid valve control: Not allowed to purge.
- Heavy fuel judgment control: Not allowed to carry out the heavy judgment.

8. ECM OPERATION AT DTC SETTING

Memorize the freeze frame data. (For test mode \$02)

AI: DTC P0172 SYSTEM TOO RICH (BANK 1)

1. OUTLINE OF DIAGNOSIS

Detect the fuel system malfunction by the amount of main feedback control.

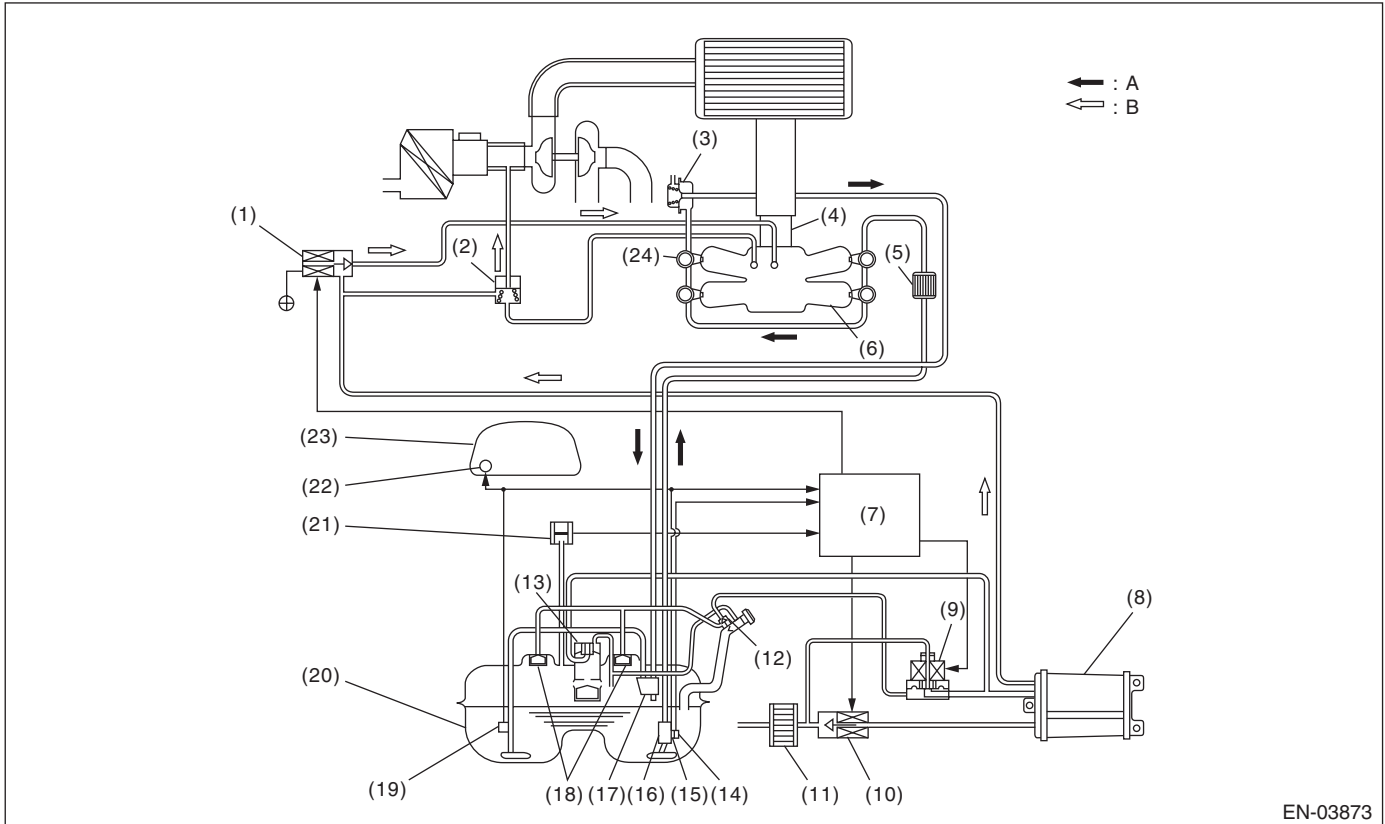

EN-03873

- | | | |
|-------------------------------------|------------------------------|--------------------------------|
| (1) Purge control solenoid valve | (10) Drain valve | (19) Fuel sub level sensor |
| (2) Purge valve | (11) Drain filter | (20) Fuel tank |
| (3) Pressure regulator | (12) Shut-off valve | (21) Fuel tank pressure sensor |
| (4) Throttle body | (13) Vent valve | (22) Fuel gauge |
| (5) Fuel filter | (14) Fuel temperature sensor | (23) Combination meter |
| (6) Intake manifold | (15) Fuel level sensor | (24) Fuel injector |
| (7) Engine control module (ECM) | (16) Fuel pump | (A) Fuel line |
| (8) Canister | (17) Jet pump | (B) Evaporation fuel line |
| (9) Pressure control solenoid valve | (18) Fuel cut valve | |

• Diagnostic Method

Fuel system is diagnosed by comparing the target air fuel ratio calculated by ECM with the actual air fuel ratio measured by sensor.

Diagnostic Trouble Code (DTC) Detecting Criteria

GENERAL DESCRIPTION

2. ENABLE CONDITION

Secondary Parameters	Enable Conditions
A/F main learning system	In operation
Engine coolant temperature	$\geq 70^{\circ}\text{C}$ (158°F)
Engine load	\geq Value of Map 5
Intake air change during 0.5 engine rev.	≤ 0.02 g/rev
Learning value of EVAP conc. during purge	≤ 0.1
Cumulative time of canister purge after engine start	20 seconds or more
Continuous period after canister purge starting	30 seconds or more

Map 5

Engine speed (rpm)	Idle	800	1200	1600	2000	2400	2800	3200	3600	4000	4400
Measured value (g (oz)/rev)	Non-turbo	0.228 (0.008)	0.22 (0.0078)	0.22 (0.0078)	0.22 (0.0078)	0.228 (0.008)	0.23 (0.0081)	0.234 (0.0083)	0.242 (0.0085)	0.250 (0.0088)	0.250 (0.0088)

3. GENERAL DRIVING CYCLE

Perform the diagnosis continuously at engine idle or constant vehicle speed after warm-up.

4. DIAGNOSTIC METHOD

• Abnormality Judgment

Judge that the fuel system malfunction occurs when the time during completing the malfunction criteria below continues 50 seconds or more by comparing the diagnosed value (fsobd) with threshold value.

Judgment Value

Malfunction Criteria	Threshold Value
$\text{fsobd} = (\text{sglmd} - \text{tglm da}) + \text{faf} + \text{flaf}$ where, sglmd = measured lambda tglm da = target lambda faf = main feedback compensation coefficient every 64 milliseconds flaf = main feedback learning compensation coefficient	$\leq \text{fsobdR1}$ See Map 4 fsobdR1 = rich side threshold value of fsobd

Map 4 Threshold value for fuel system malfunction criteria

Amount of air (g (oz)/s)	0	2.4 (0.085)	4.7 (0.166)	7 (0.247)	9.4 (0.332)	11.7 (0.413)	14.1 (0.497)
fsobdR1 (%)	-40	-40	-36.9	-32.0	-27.0	-27.0	-27.0

Time Needed for Diagnosis: 10 seconds \times 5 times

Malfunction Indicator Light Illumination: Illuminates when malfunction occurs in 2 continuous driving cycles.

• Normality Judgment

Judge OK when the malfunction criteria below are continued for 10 seconds.

Judgment Value

Malfunction Criteria	Threshold Value
$\text{fsobd} = (\text{sglmd} - \text{tglm da}) + \text{faf} + \text{flaf}$	$\geq -20\%$

Diagnostic Trouble Code (DTC) Detecting Criteria

GENERAL DESCRIPTION

5. DTC CLEAR CONDITION

- When the OK idling cycle was completed 40 times in a row
- When "Clear Memory" was performed

6. MALFUNCTION INDICATOR LIGHT CLEAR CONDITION

- When OK with similar drive in 3 drive cycles.
- When "Clear Memory" was performed

7. FAIL SAFE

Rich side malfunction

- Purge control solenoid valve control: Not allowed to purge.
- Heavy fuel judgment control: Not allowed to carry out the heavy judgment.

8. ECM OPERATION AT DTC SETTING

Memorize the freeze frame data. (For test mode \$02)

AJ:DTC P0181 FUEL TEMPERATURE SENSOR “A” CIRCUIT RANGE/PERFORMANCE

1. OUTLINE OF DIAGNOSIS

Detect the malfunction of fuel temperature sensor output property. Perform the diagnosis in two methods; namely, drift diagnosis and stuck diagnosis. Judge NG when either of them results in NG, and judge OK when both of them result in OK.

• **Drift Diagnosis**

Normally fuel temperature is lower than engine coolant temperature. When the fuel temperature becomes higher than the engine coolant temperature, the range is considered to be shifted, and make an NG judgment.

2. COMPONENT DESCRIPTION

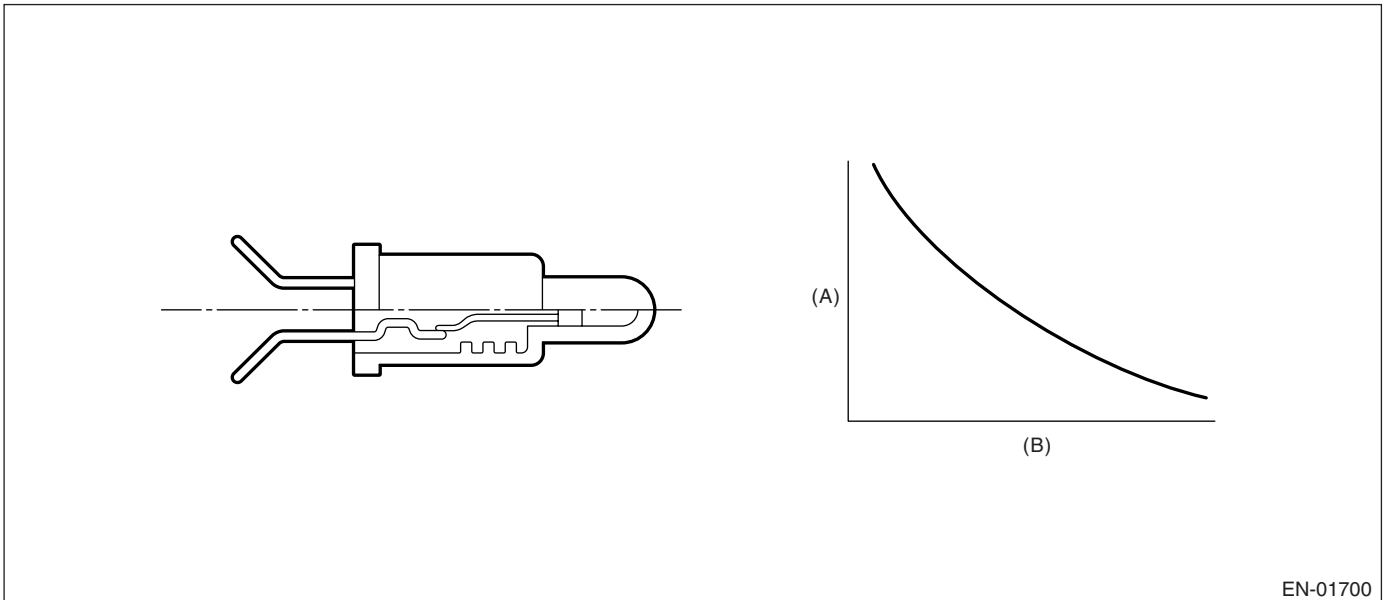

EN-01700

- (A) Resistance value (Ω)
- (B) Fuel temperature $^{\circ}\text{C}$ ($^{\circ}\text{F}$)

3. ENABLE CONDITION

Secondary Parameters	Enable Conditions
None	

4. GENERAL DRIVING CYCLE

Always perform the diagnosis continuously.

Diagnostic Trouble Code (DTC) Detecting Criteria

GENERAL DESCRIPTION

5. DIAGNOSTIC METHOD

• Abnormality Judgment

Judge NG when the continuous time of completing the malfunction criteria below becomes more than 120 seconds.

Judgment Value

Malfunction Criteria	Threshold Value
Fuel level	≥ 9 ℓ (2.38 US gal, 1.98 Imp gal)
After engine starting	20 seconds or more
Engine coolant temperature – engine coolant temperature at engine starting	≥ 10°C (18°F)
Fuel temperature – engine coolant temperature	≥ 10°C (18°F)
Battery voltage	> 10.9 V

Time Needed for Diagnosis: 120 seconds

Malfunction Indicator Light Illumination: Illuminates when malfunction occurs in 2 continuous driving cycles.

• Normality Judgment

Judge OK when the malfunction criteria below are completed.

Judgment Value

Malfunction Criteria	Threshold Value
Fuel level	≥ 9 ℓ (2.38 US gal, 1.98 Imp gal)
After engine starting	20 seconds or more
Engine coolant temperature – engine coolant temperature at engine starting	≥ 10°C (18°F)
Fuel temperature – engine coolant temperature	< 10°C (18°F)
Battery voltage	> 10.9 V
Engine coolant temperature	< 70°C (158°F)

• Stuck Diagnosis

If the fuel temperature which might rise along with the engine idling (the cumulative amount of intake air after engine starting is large) does not increase, the engine is considered to be stuck and make an NG judgment.

6. ENABLE CONDITION

Secondary Parameters	Enable Conditions
After engine starting	20 seconds or more
Battery voltage	> 10.9 V

7. GENERAL DRIVING CYCLE

Always perform diagnosis continuously.

8. DIAGNOSTIC METHOD

• Abnormality Judgment

Judge NG when the malfunction criteria below are completed.

Judgment Value

Malfunction Criteria	Threshold Value
Accumulated amount of intake air	≥ 550 kg (1,212.8 lb)
Fuel temperature difference between Max. and Min.	< 3°C (5.4°F)

Time Needed for Diagnosis: To be determined.

Diagnostic Trouble Code (DTC) Detecting Criteria

GENERAL DESCRIPTION

Malfunction Indicator Light Illumination: Illuminates when malfunction occurs in 2 continuous driving cycles.

• Normality Judgment

Judge OK when the malfunction criteria below are completed.

Judgment Value

Malfunction Criteria	Threshold Value
Accumulated amount of intake air	≥ 550 kg (1,212.8 lb)
Fuel temperature difference between Max. and Min.	$\geq 3^{\circ}\text{C}$ (5.4 $^{\circ}\text{F}$)

9. DTC CLEAR CONDITION

- When the OK idling cycle was completed 40 times in a row
- When "Clear Memory" was performed

10.MALFUNCTION INDICATOR LIGHT CLEAR CONDITION

- When the OK driving cycle was completed 3 times in a row
- When "Clear Memory" was performed

11.FAIL SAFE

None

12.ECM OPERATION AT DTC SETTING

Memorize the freeze frame data. (For test mode \$02)

Diagnostic Trouble Code (DTC) Detecting Criteria

GENERAL DESCRIPTION

AK:DTC P0182 FUEL TEMPERATURE SENSOR “A” CIRCUIT LOW INPUT

1. OUTLINE OF DIAGNOSIS

Detect the open or short circuit of fuel temperature sensor. Judge NG when out of the standard value.

2. COMPONENT DESCRIPTION

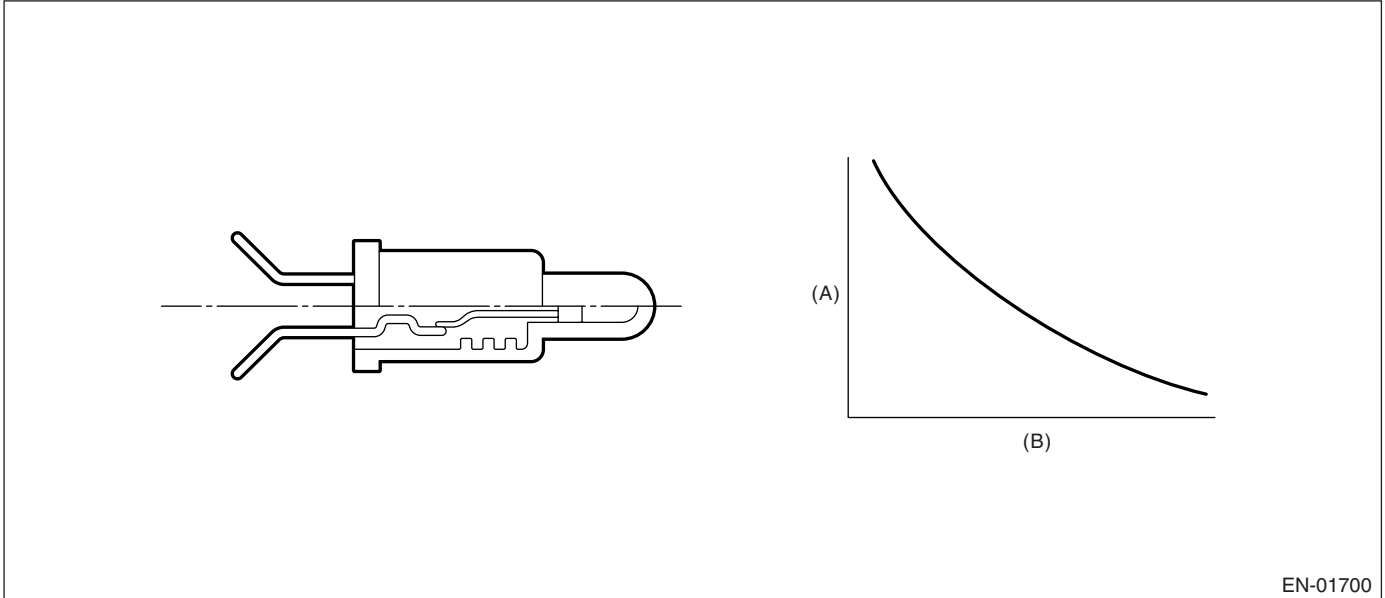

(A) Resistance value (Ω)

(B) Fuel temperature $^{\circ}\text{C}$ ($^{\circ}\text{F}$)

3. ENABLE CONDITION

Secondary Parameters	Enable Conditions
None	

4. GENERAL DRIVING CYCLE

Always perform the diagnosis continuously.

5. DIAGNOSTIC METHOD

• Abnormality Judgment

Judge NG when the continuous time of completing the malfunction criteria below becomes more than 2.5 seconds.

Judgment Value

Malfunction Criteria	Threshold Value
Output voltage	$< 0.1646 \text{ V}$
Battery voltage	$\geq 10.9 \text{ V}$

Time Needed for Diagnosis: 2.5 seconds

Malfunction Indicator Light Illumination: Illuminates as soon as the malfunction occurs.

• Normality Judgment

Judge OK when the cumulative time until completing the malfunction criteria below becomes more than 2.5 seconds.

Judgment Value

Malfunction Criteria	Threshold Value
Output voltage	$\geq 0.1646 \text{ V}$
Battery voltage	$\geq 10.9 \text{ V}$

Diagnostic Trouble Code (DTC) Detecting Criteria

GENERAL DESCRIPTION

6. DTC CLEAR CONDITION

- When the OK idling cycle was completed 40 times in a row
- When "Clear Memory" was performed

7. MALFUNCTION INDICATOR LIGHT CLEAR CONDITION

- When the OK driving cycle was completed 3 times in a row
- When "Clear Memory" was performed

8. FAIL SAFE

None

9. ECM OPERATION AT DTC SETTING

Memorize the freeze frame data. (For test mode \$02)

Diagnostic Trouble Code (DTC) Detecting Criteria

GENERAL DESCRIPTION

AL:DTC P0183 FUEL TEMPERATURE SENSOR "A" CIRCUIT HIGH INPUT

1. OUTLINE OF DIAGNOSIS

Detect the open or short circuit of fuel temperature sensor. Judge NG when out of the standard value.

2. COMPONENT DESCRIPTION

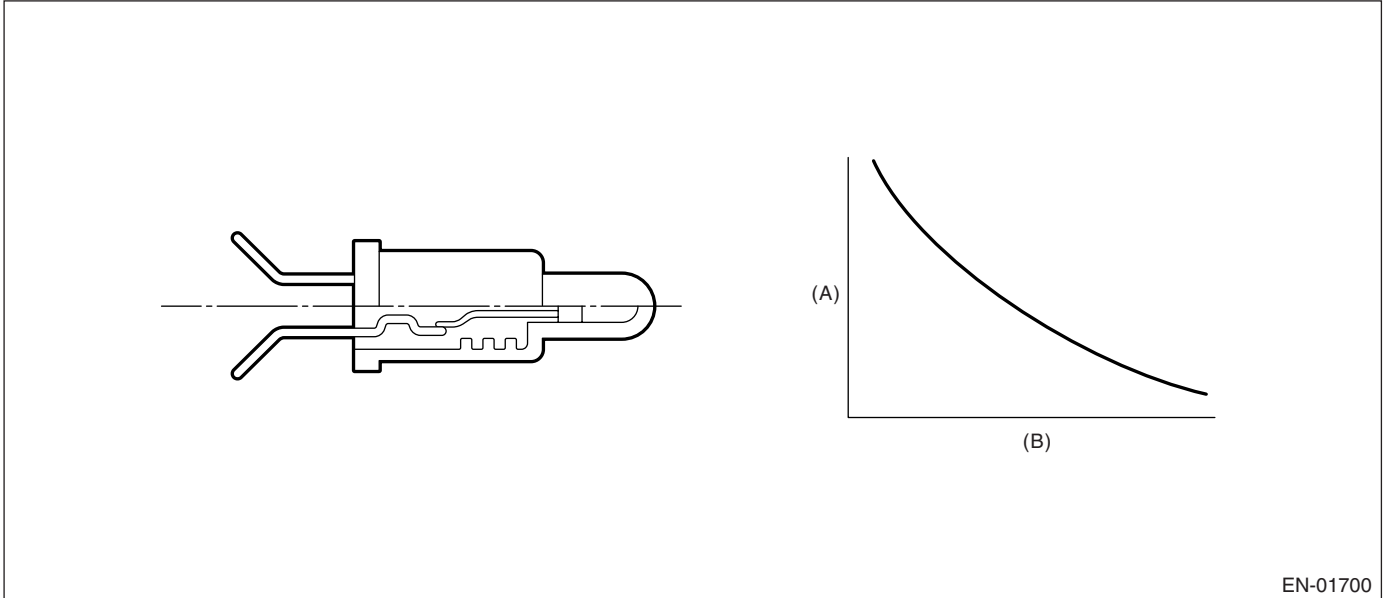

(A) Resistance value (Ω)

(B) Fuel temperature $^{\circ}\text{C}$ ($^{\circ}\text{F}$)

3. ENABLE CONDITION

Secondary Parameters	Enable Conditions
None	

4. GENERAL DRIVING CYCLE

Always perform the diagnosis continuously.

5. DIAGNOSTIC METHOD

• Abnormality Judgment

Judge NG when the continuous time of completing the malfunction criteria below becomes more than 2.5 seconds.

Judgment Value

Malfunction Criteria	Threshold Value
Output voltage	$\geq 4.72 \text{ V}$
Battery voltage	$\geq 10.9 \text{ V}$

Time Needed for Diagnosis: 2.5 seconds

Malfunction Indicator Light Illumination: Illuminates as soon as the malfunction occurs.

• Normality Judgment

Judge OK when the cumulative time until completing the malfunction criteria below becomes more than 2.5 seconds.

Judgment Value

Malfunction Criteria	Threshold Value
Output voltage	$< 4.72 \text{ V}$
Battery voltage	$\geq 10.9 \text{ V}$

Diagnostic Trouble Code (DTC) Detecting Criteria

GENERAL DESCRIPTION

6. DTC CLEAR CONDITION

- When the OK idling cycle was completed 40 times in a row
- When "Clear Memory" was performed

7. MALFUNCTION INDICATOR LIGHT CLEAR CONDITION

- When the OK driving cycle was completed 3 times in a row
- When "Clear Memory" was performed

8. FAIL SAFE

None

9. ECM OPERATION AT DTC SETTING

Memorize the freeze frame data. (For test mode \$02)

Diagnostic Trouble Code (DTC) Detecting Criteria

GENERAL DESCRIPTION

AM:DTC P0222 THROTTLE/PEDAL POSITION SENSOR/SWITCH “B” CIRCUIT LOW

1. OUTLINE OF DIAGNOSIS

Detect the open or short circuit of throttle position sensor 2.
Judge NG when out of the standard value.

2. COMPONENT DESCRIPTION

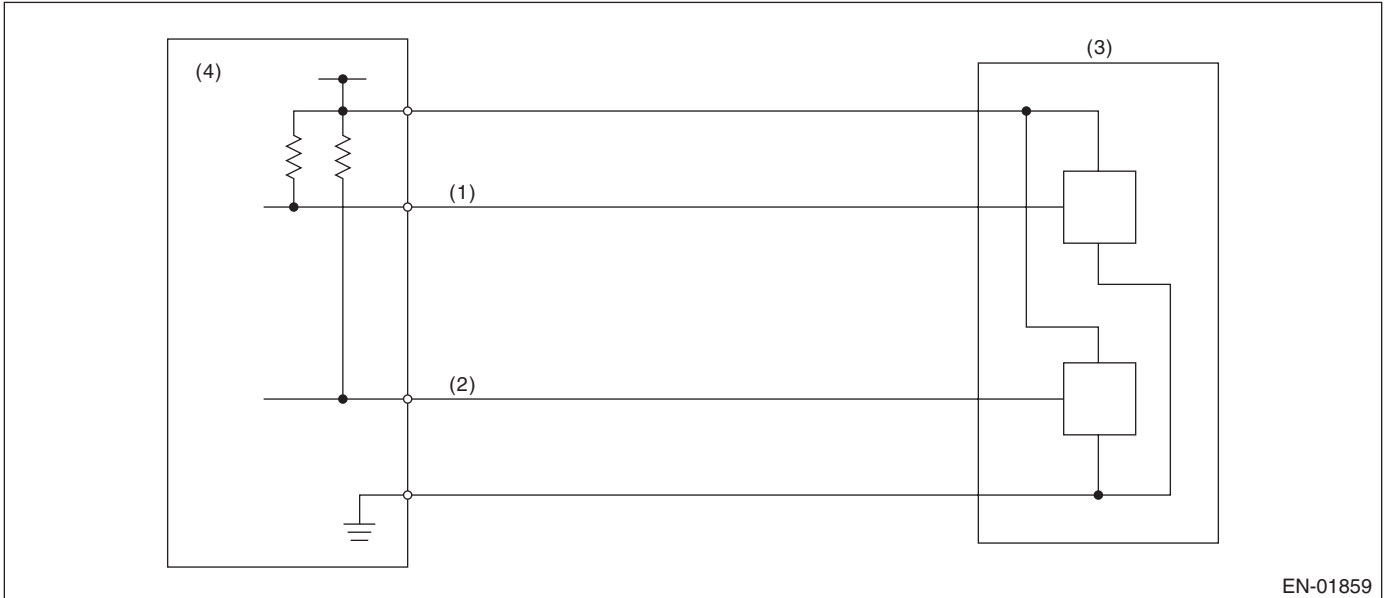

EN-01859

- (1) Throttle position sensor 1 signal (3) Throttle position sensor
(2) Throttle position sensor 2 signal (4) Engine control module (ECM)

3. ENABLE CONDITION

Secondary Parameters	Enable Conditions
Ignition switch	ON

4. GENERAL DRIVING CYCLE

Always perform the diagnosis continuously.

5. DIAGNOSTIC METHOD

Judge OK and clear the NG when the malfunction criteria below are completed.

Judgment Value

Malfunction Criteria	Threshold Value
Sensor 1 input voltage	> 0.224 V

Time Needed for Diagnosis: 24 milliseconds

Malfunction Indicator Light Illumination: Illuminates as soon as malfunction occurs.

6. DTC CLEAR CONDITION

- When the OK idling cycle was completed 40 times in a row
- When “Clear Memory” was performed (Only with engine stopped)

7. MALFUNCTION INDICATOR LIGHT CLEAR CONDITION

- When the OK driving cycle was completed 3 times in a row
- When “Clear Memory” was performed (Only with engine stopped)

8. FAIL SAFE

Stop power distribution to electronic throttle control motor. (Throttle opening is fixed to 6°.)

9. ECM OPERATION AT DTC SETTING

Memorize the freeze frame data. (For test mode \$02)

AN:DTC P0223 THROTTLE/PEDAL POSITION SENSOR/SWITCH “B” CIRCUIT HIGH

1. OUTLINE OF DIAGNOSIS

Detect the open or short circuit of throttle position sensor 2.
Judge NG when out of the standard value.

2. COMPONENT DESCRIPTION

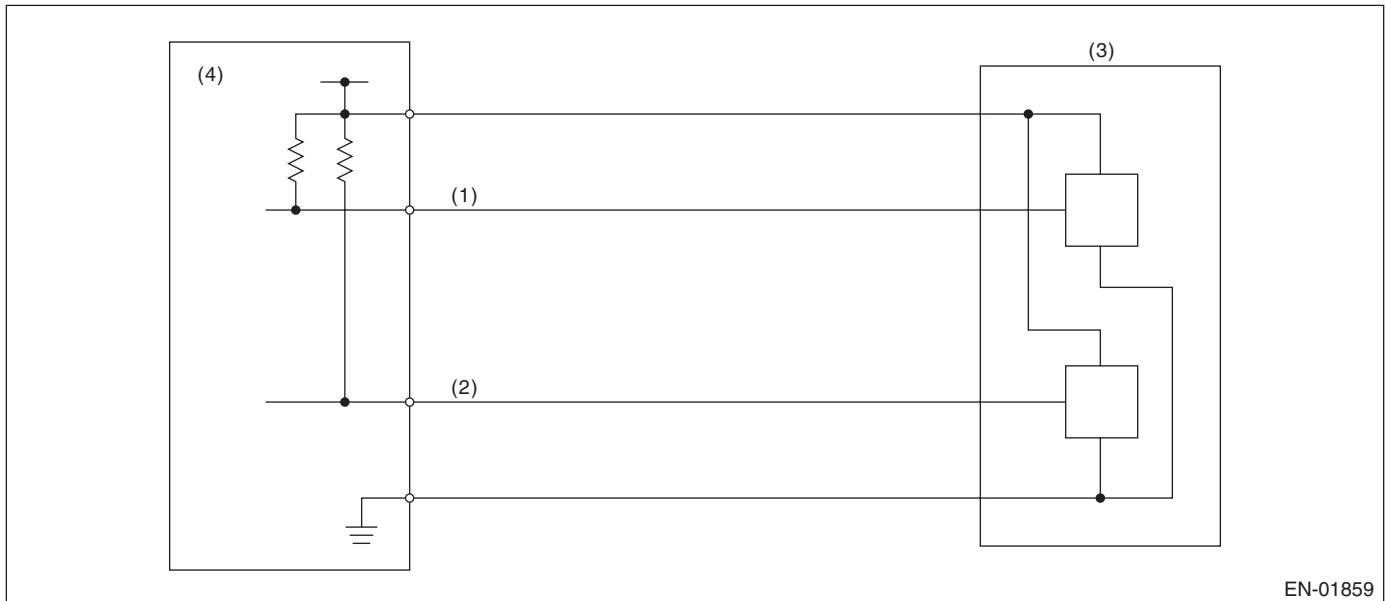

- | | |
|---------------------------------------|---------------------------------|
| (1) Throttle position sensor 1 signal | (3) Throttle position sensor |
| (2) Throttle position sensor 2 signal | (4) Engine control module (ECM) |

3. ENABLE CONDITION

Secondary Parameters	Enable Conditions
Ignition switch	ON

4. GENERAL DRIVING CYCLE

Always perform the diagnosis continuously.

5. DIAGNOSTIC METHOD

Judge OK and clear the NG when the malfunction criteria below are completed.

Judgment Value

Malfunction Criteria	Threshold Value
Sensor 1 input voltage	< 4.851 V

Time Needed for Diagnosis: 24 milliseconds

Malfunction Indicator Light Illumination: Illuminates as soon as malfunction occurs.

Diagnostic Trouble Code (DTC) Detecting Criteria

GENERAL DESCRIPTION

6. DTC CLEAR CONDITION

- When the OK idling cycle was completed 40 times in a row
- When "Clear Memory" was performed (Only with engine stopped)

7. MALFUNCTION INDICATOR LIGHT CLEAR CONDITION

- When the OK driving cycle was completed 3 times in a row
- When "Clear Memory" was performed (Only with engine stopped)

8. FAIL SAFE

Stop power distribution to electronic throttle control motor. (Throttle opening is fixed to 6°.)

9. ECM OPERATION AT DTC SETTING

Memorize the freeze frame data. (For test mode \$02)

Diagnostic Trouble Code (DTC) Detecting Criteria

GENERAL DESCRIPTION

AO:DTC P0230 FUEL PUMP PRIMARY CIRCUIT

1. OUTLINE OF DIAGNOSIS

Detect the malfunction of fuel pump control unit. Judge NG when the NG signal is sent through a diagnostic line coming from the fuel pump control unit. Fuel pump control unit detects the open or short circuit malfunction for each line, and then sends NG signals if one of them is found NG.

2. COMPONENT DESCRIPTION

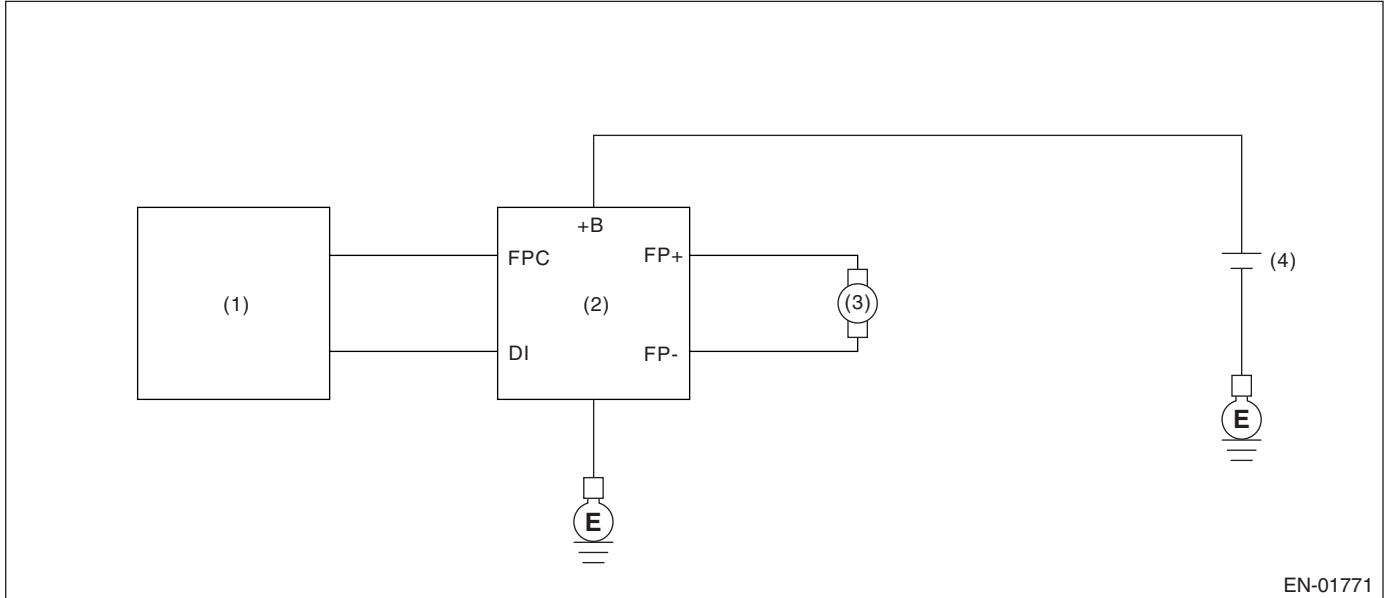

EN-01771

- (1) Engine control module (ECM)
- (2) Fuel pump control unit
- (3) Fuel pump
- (4) Battery

3. ENABLE CONDITION

Secondary Parameters	Enable Conditions
None	

4. GENERAL DRIVING CYCLE

Always perform the diagnosis continuously.

5. DIAGNOSTIC METHOD

• Abnormality Judgment

Judge NG when the continuous time of completing the malfunction criteria below becomes more than 2.5 seconds.

Judgment Value

Malfunction Criteria	Threshold Value
Battery voltage	≥ 8 V
After engine starting	30 seconds or more
Fuel pump control	ON
Fuel pump control unit output diagnosis signal	Low
Fuel level	≥ 10 ℓ (2.6 US gal, 2.2 Imp gal)

Time Needed for Diagnosis: 2.5 seconds

Diagnostic Trouble Code (DTC) Detecting Criteria

GENERAL DESCRIPTION

Malfunction Indicator Light Illumination: Illuminates when malfunction occurs in 2 continuous driving cycles.

• Normality Judgment

Judge OK and clear the NG when the malfunction criteria below are completed.

Judgment Value

Malfunction Criteria	Threshold Value
Battery voltage	≥ 8 V
After engine starting	30 seconds or more
Fuel pump control	ON
Fuel pump control unit output diagnosis signal	High

6. DTC CLEAR CONDITION

- When the OK idling cycle was completed 40 times in a row
- When "Clear Memory" was performed

7. MALFUNCTION INDICATOR LIGHT CLEAR CONDITION

- When the OK driving cycle was completed 3 times in a row
- When "Clear Memory" was performed

8. FAIL SAFE

OFF setting may be needed depending on the NG portion.

9. ECM OPERATION AT DTC SETTING

Memorize the freeze frame data. (For test mode \$02)

Diagnostic Trouble Code (DTC) Detecting Criteria

GENERAL DESCRIPTION

AP:DTC P0244 TURBO/SUPER CHARGER WASTEGATE SOLENOID "A" RANGE/PERFORMANCE

1. OUTLINE OF DIAGNOSIS

Detect the malfunction of wastegate control solenoid valve function. Judge NG when becoming high wastegate pressure.

2. COMPONENT DESCRIPTION

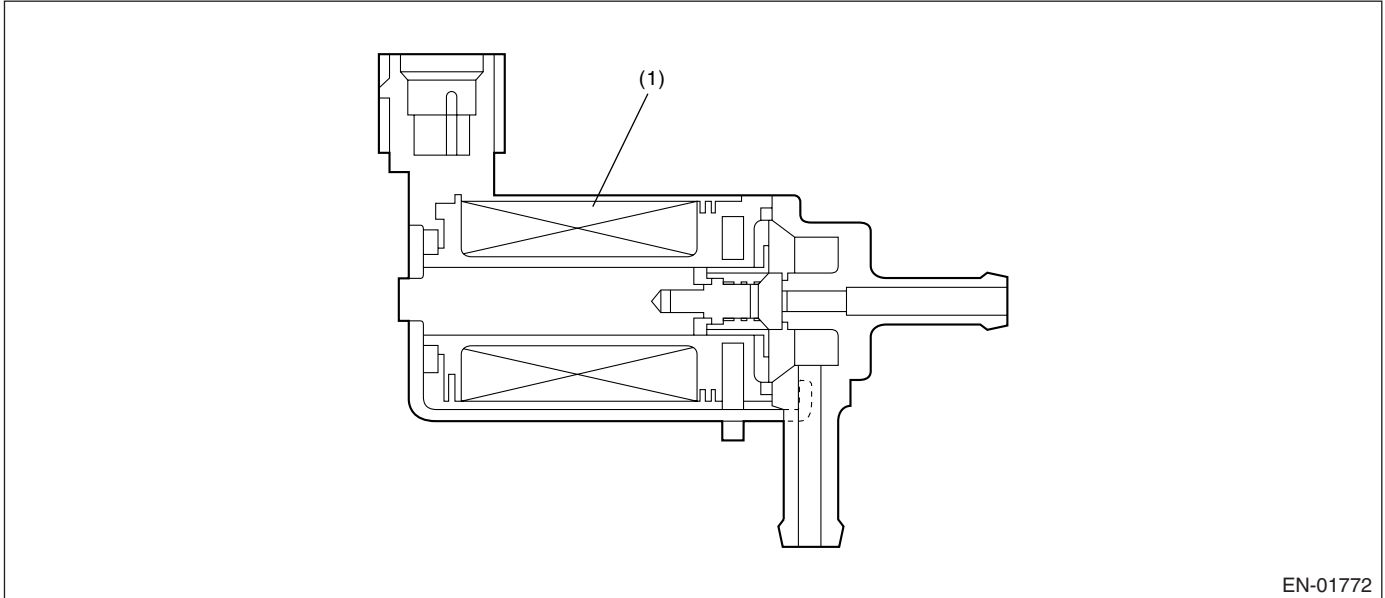

EN-01772

(1) Coil

3. ENABLE CONDITION

Secondary Parameters	Enable Conditions
None	

4. GENERAL DRIVING CYCLE

Always perform the diagnosis continuously.

5. DIAGNOSTIC METHOD

• Abnormality Judgment

Judge NG when the continuous time of completing the malfunction criteria below becomes more than 1 second.

Judgment Value

Malfunction Criteria	Threshold Value
Intake manifold pressure	≥ Map 10

Map 10

Atmospheric pressure (kPa (mmHg, inHg))	58.7 (440, 17.3)	67.2 (504, 19.8)	75.7 (568, 22.4)	84.2 (632, 24.9)	92.8 (696, 27.4)	101.3 (760, 29.9)
NG pressure (kPa (mmHg, inHg))	142.4 (1,068, 42.1)	156.2 (1,172, 46.1)	170.2 (1,277, 50.3)	184.1 (1,381, 54.4)	198.0 (1,485, 58.5)	207.9 (1,560, 61.4)
OK pressure (kPa (mmHg, inHg))	120.0 (900, 35.4)	113.8 (1,004, 33.6)	147.8 (1,109, 43.7)	161.7 (1,213, 47.8)	175.6 (1,317, 51.9)	185.6 (1,392, 54.8)

Time Needed for Diagnosis: 1 second

Diagnostic Trouble Code (DTC) Detecting Criteria

GENERAL DESCRIPTION

Malfunction Indicator Light Illumination: Illuminates as soon as malfunction occurs.

• **Normality Judgment**

Judge OK and clear the NG when the malfunction criteria below are completed.

Judgment Value

Malfunction Criteria	Threshold Value
Intake manifold pressure	< Map 10

6. DTC CLEAR CONDITION

- When the OK idling cycle was completed 40 times in a row
- When "Clear Memory" was performed

7. MALFUNCTION INDICATOR LIGHT CLEAR CONDITION

- When the OK driving cycle was completed 3 times in a row
- When "Clear Memory" was performed

8. FAIL SAFE

None

9. ECM OPERATION AT DTC SETTING

Memorize the freeze frame data. (For test mode \$02)

Diagnostic Trouble Code (DTC) Detecting Criteria

GENERAL DESCRIPTION

AQ:DTC P0245 TURBO/SUPER CHARGER WASTEGATE SOLENOID "A" LOW

1. OUTLINE OF DIAGNOSIS

Detect the open or short circuit of wastegate control solenoid valve. Judge NG when the terminal output voltage remains Low during outputting the duty signal.

2. COMPONENT DESCRIPTION

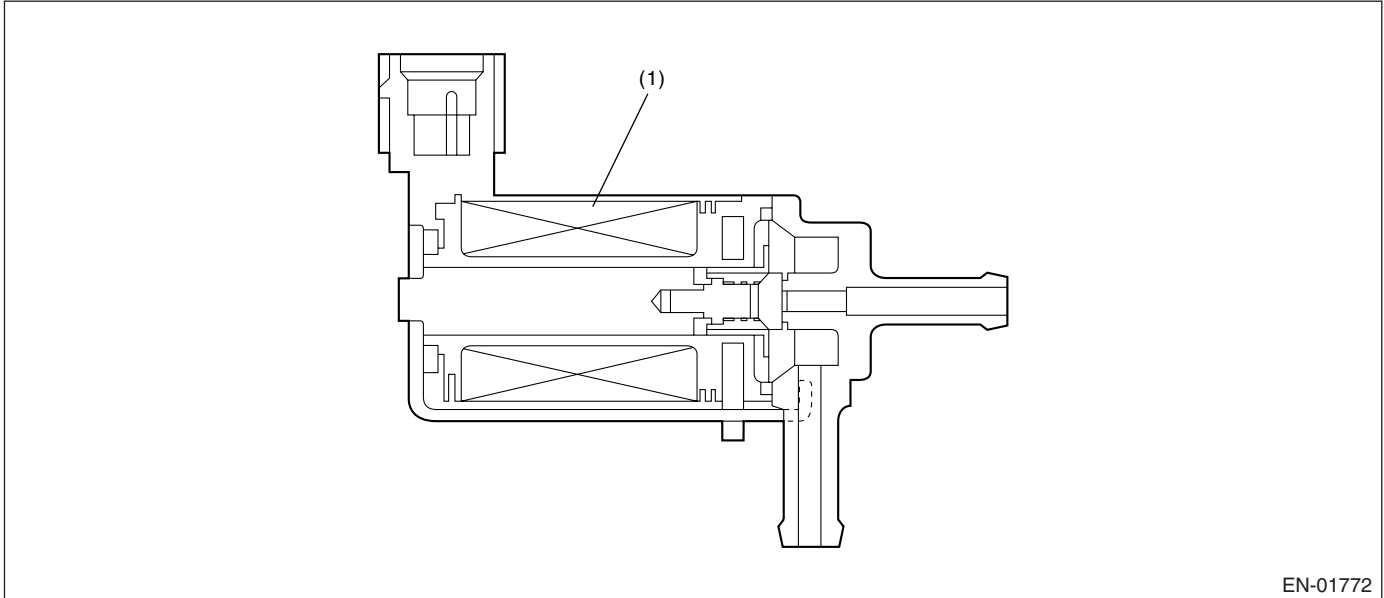

EN-01772

(1) Coil

3. ENABLE CONDITION

Secondary Parameters	Enable Conditions
Battery voltage	> 10.9 V
After engine starting	1 second or more

4. GENERAL DRIVING CYCLE

Perform the diagnosis continuously after engine starts.

5. DIAGNOSTIC METHOD

• Abnormality Judgment

Judge NG when the continuous time until completing the malfunction criteria below becomes more than 655 milliseconds.

Judgment Value

Malfunction Criteria	Threshold Value
Terminal output voltage	Low
Duty ratio for turbocharged pressure control	< 75%

Time Needed for Diagnosis: 655 milliseconds

Malfunction Indicator Light Illumination: Illuminates as soon as the malfunction occurs.

• Normality Judgment

Judge OK and clear NG when the malfunction criteria below are completed.

Judgment Value

Malfunction Criteria	Threshold Value
Terminal output voltage	High

Diagnostic Trouble Code (DTC) Detecting Criteria

GENERAL DESCRIPTION

6. DTC CLEAR CONDITION

- When the OK idling cycle was completed 40 times in a row
- When "Clear Memory" was performed

7. MALFUNCTION INDICATOR LIGHT CLEAR CONDITION

- When the OK driving cycle was completed 3 times in a row
- When "Clear Memory" was performed

8. FAIL SAFE

None

9. ECM OPERATION AT DTC SETTING

Memorize the freeze frame data. (For test mode \$02)

AR:DTC P0246 TURBO/SUPER CHARGER WASTEGATE SOLENOID “A” HIGH

1. OUTLINE OF DIAGNOSIS

Detect the open or short circuit of wastegate control solenoid valve. Judge NG when the terminal output voltage remains Low or High during outputting the duty signal.

2. COMPONENT DESCRIPTION

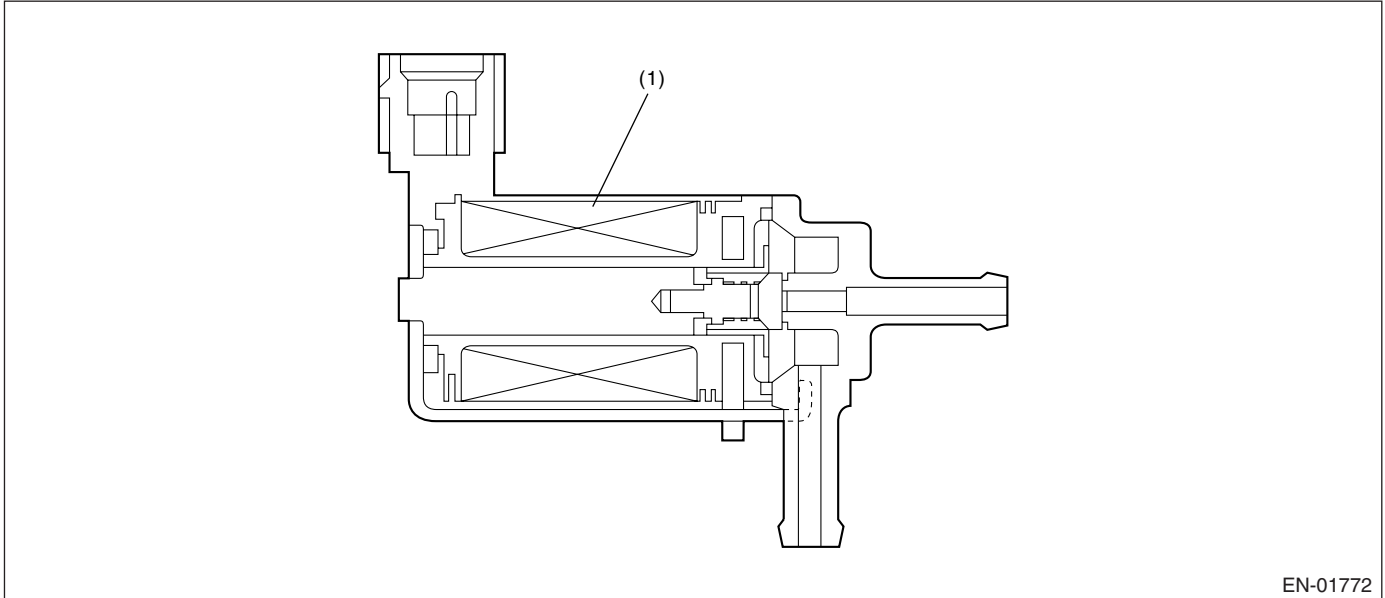

EN-01772

(1) Coil

3. ENABLE CONDITION

Secondary Parameters	Enable Conditions
Battery voltage	> 10.9 V
After engine starting	1 second or more

4. GENERAL DRIVING CYCLE

Perform the diagnosis continuously after engine starts.

5. DIAGNOSTIC METHOD

• Abnormality Judgment

Judge NG when the continuous time until completing the malfunction criteria below becomes more than 655 milliseconds.

Judgment Value

Malfunction Criteria	Threshold Value
Terminal output voltage	High
Duty ratio for turbocharged pressure control	> 25%

Time Needed for Diagnosis: 655 milliseconds

Malfunction Indicator Light Illumination: Illuminates as soon as the malfunction occurs.

• Normality Judgment

Judge OK and clear NG when a malfunction criteria below are completed.

Judgment Value

Malfunction Criteria	Threshold Value
Terminal output voltage	Low

Diagnostic Trouble Code (DTC) Detecting Criteria

GENERAL DESCRIPTION

6. DTC CLEAR CONDITION

- When the OK idling cycle was completed 40 times in a row
- When "Clear Memory" was performed

7. MALFUNCTION INDICATOR LIGHT CLEAR CONDITION

- When the OK driving cycle was completed 3 times in a row
- When "Clear Memory" was performed

8. FAIL SAFE

None

9. ECM OPERATION AT DTC SETTING

Memorize the freeze frame data. (For test mode \$02)

Diagnostic Trouble Code (DTC) Detecting Criteria

GENERAL DESCRIPTION

AS:DTC P0301 CYLINDER 1 MISFIRE DETECTED

1. OUTLINE OF DIAGNOSIS

Detect whether the misfire occurred or not. (Revolution fluctuation method) Monitoring the misfire which influences exhaust deterioration (1.5 times of FTP) and catalyst damage is made obligatory by the law. Misfire affecting these two has three patterns below.

- Intermittent misfire (The same cylinder misfires in random, or different cylinders misfire in random.): FTP 1.5 times misfire
- Every time misfire (The same cylinder misfires every time.): FTP 1.5 times misfire, Catalyst damage misfire

The following detecting methods are adopted for these detection.

1) Intermittent misfire: FTP 1.5 times misfire

- 180° Interval Difference Method (MT: 1,800 rpm or less; AT: None)
- 360° Interval Difference Method (whole range)
- 720° Interval Difference Method (3,000 rpm or less)

2) Every time misfire: FTP 1.5 times misfire, Catalyst damage misfire

- 360° Interval Difference Method

2. ENABLE CONDITION

Secondary Parameters	Enable Conditions
Continuous time for completing all secondary parameters	≥ 1 second
Intake manifold pressure change during 0.5 engine rev.	< 13.3 kPa (100 mmHg, 3.93 inHg) (MT) < 13.3 kPa (100 mmHg, 3.93 inHg) (AT)
Engine speed change	< 1,000 rpm/32 milliseconds
Throttle position change during 16 milliseconds	< 14°
Fuel shut-off function	Not in operation
Atmospheric pressure	≥ 75.0 kPa (563 mmHg, 22.2 inHg)
Fuel level	≥ 9 ℓ (2.38 US gal, 1.98 Imp gal)
Evaporative system leak check	Not in operation
Engine speed	500 — 6,500 rpm
Intake manifold pressure	> Value of Map 3
Battery voltage	≥ 8 V

Map3

MT model

Vehicle Speed < 64.4 km/h (40 MPH)

rpm	700	1000	1500	2000	2500	3000	3500	4000	4500	5000	5500	6000	6500	6700
kPa	25.1	24.8	23.3	24.7	24.0	25.6	28.8	30.0	31.6	32.5	37.1	41.9	36.9	51.1
(mmHg, inHg)	(188, 7.40)	(186, 7.32)	(175, 6.89)	(185, 7.30)	(180, 7.09)	(192, 7.56)	(216, 8.51)	(225, 8.86)	(237, 9.33)	(244, 9.60)	(278, 10.96)	(314, 12.4)	(352, 10.90)	(383, 15.1)

Vehicle Speed ≥ 64.4 km/h (40 MPH)

rpm	700	1000	1500	2000	2500	3000	3500	4000	4500	5000	5500	6000	6500	6700
kPa	25.1	24.8	23.3	24.7	24.0	25.6	28.8	30.0	31.6	32.5	37.1	41.9	36.9	51.1
(mmHg, inHg)	(188, 7.40)	(186, 7.32)	(175, 6.89)	(185, 7.30)	(180, 7.09)	(192, 7.56)	(216, 8.51)	(225, 8.86)	(237, 9.33)	(244, 9.60)	(278, 10.96)	(314, 12.4)	(352, 10.90)	(383, 15.1)

Diagnostic Trouble Code (DTC) Detecting Criteria

GENERAL DESCRIPTION

AT model

rpm	700	1000	1500	2000	2500	3000	3500	4000	4500	5000	5500	6000	6500	6700
kPa (mmHg, inHg)	26.3 (197, 7.76)	24.7 (185, 7.28)	23.6 (177, 6.97)	26.7 (200, 7.89)	27.3 (205, 8.07)	26.1 (196, 7.72)	29.5 (221.5, 8.72)	31.3 (235, 9.25)	32.7 (245.5, 9.67)	34.1 (256, 10.08)	38.2 (286.5, 11.28)	44.0 (330, 13.0)	49.5 (371.5, 14.63)	53.3 (400, 15.74)

3. GENERAL DRIVING CYCLE

- Detecting misfire is able to be carried out in the condition between idling and high revolution.
- Perform the diagnosis continuously.

4. DIAGNOSTIC METHOD

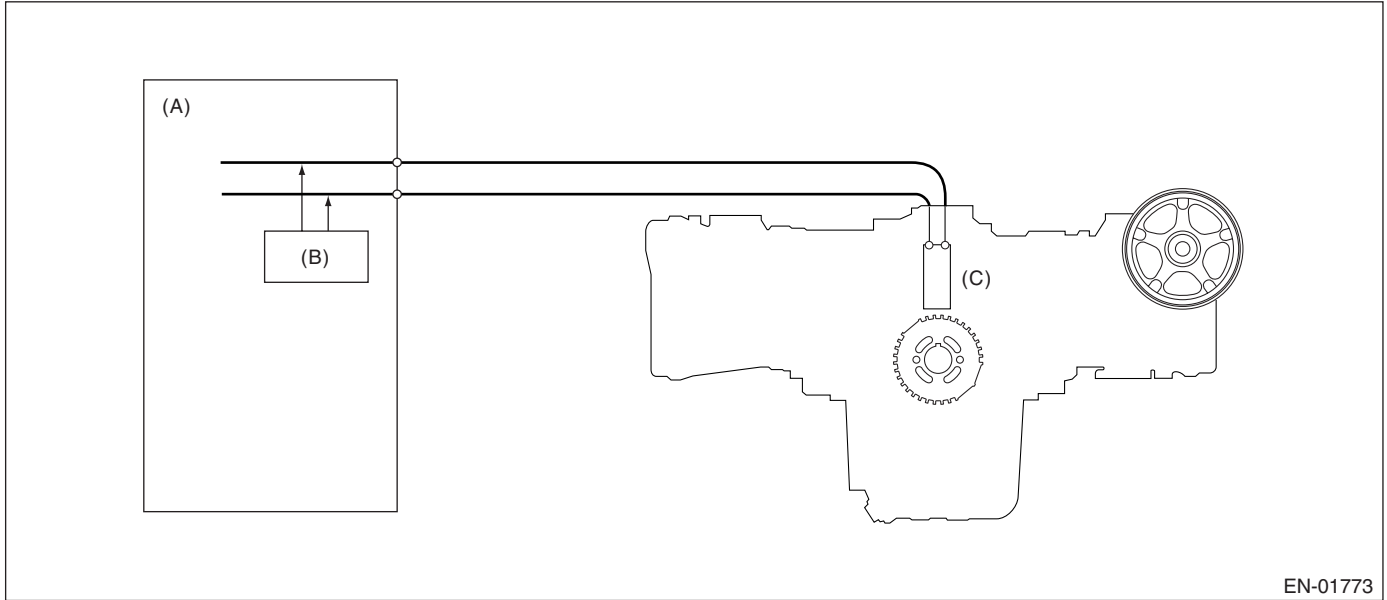

EN-01773

- (A) Engine control module (ECM)
 (B) Diagnosis circuit
 (C) Crankshaft position sensor

When the misfire occurred, the engine speed is decreased and the crankshaft position speed will change. Calculate the interval difference value (diagnostic value) from crankshaft position speed by the following formula, and judge whether the misfire occurs or not comparing the calculated result with judgment value. Counting the number of misfire up, and if the misfire ratio is higher during 1,000 rev. or 200 rev., judge NG for the corresponding cylinder.

Calculate the diagnostic value (from crankshaft position speed)	→ Misfire detection every single ignition (Compare diagnostic value with judgment value)	→ NG judgment (Judge misfire occurrence required by the law) (Compare number of misfire with judgment)
	<ul style="list-style-type: none"> • 180° Interval Difference Method • 360° Interval Difference Method • 720° Interval Difference Method 	<ul style="list-style-type: none"> • FTP1.5 times misfire NG judgment • Catalyst damage misfire NG judgment

Diagnostic Trouble Code (DTC) Detecting Criteria

GENERAL DESCRIPTION

As the following figure, pick out a random cylinder as the standard and name it omg 0. And the former crankshaft position speed is named omg 1, the second former crankshaft position speed is named omg 2, the third is named omg 3, and the following is the same.

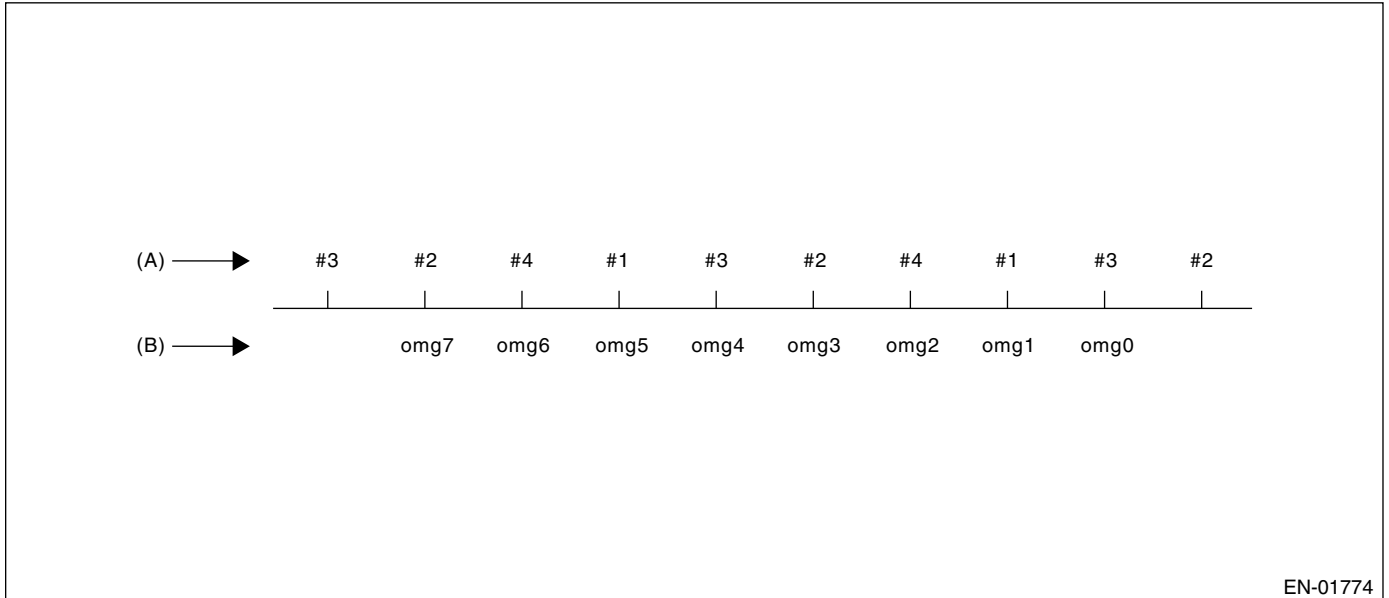

EN-01774

- (A) Ignition order
- (B) Crankshaft position speed

• 180° Interval Difference Method

Diagnosis value	$domg180 = (omg_{-1} - omg_0) - (omg_7 - omg_1)/6$
Judge misfire occurs in the following cases.	
<ul style="list-style-type: none"> • $domg180 >$ judgment value of positive side • $domg180 \leq$ judgment value of negative side (judgment value before 180°CA)	

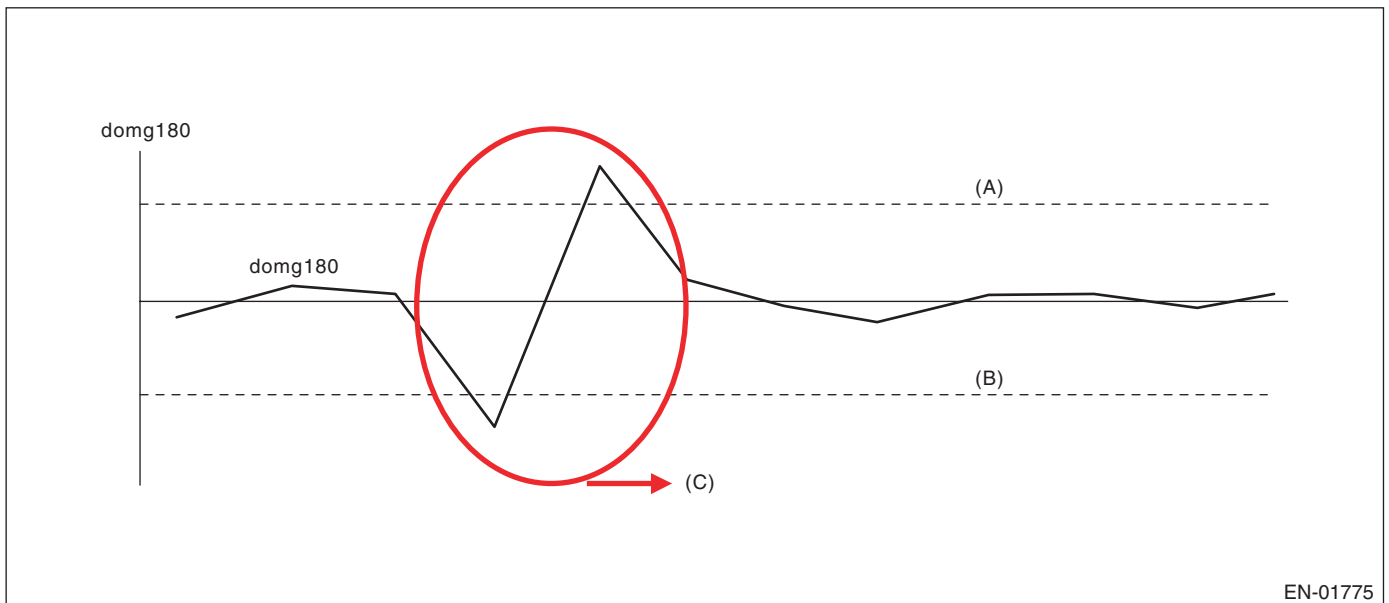

EN-01775

- (A) Threshold value (Judgment value of positive side)
- (B) Threshold value (Judgment value of negative side)
- (C) Judged as misfire

Diagnostic Trouble Code (DTC) Detecting Criteria

GENERAL DESCRIPTION

• 360° Interval Difference Method

Diagnosis value	$\text{domg } 360 = (\text{omg } 1 - \text{omg } 0) - (\text{omg } 4 - \text{omg } 3)$
Misfire judgment	$\text{domg } 360 > \text{judgment value} \rightarrow \text{Misfire occurs}$

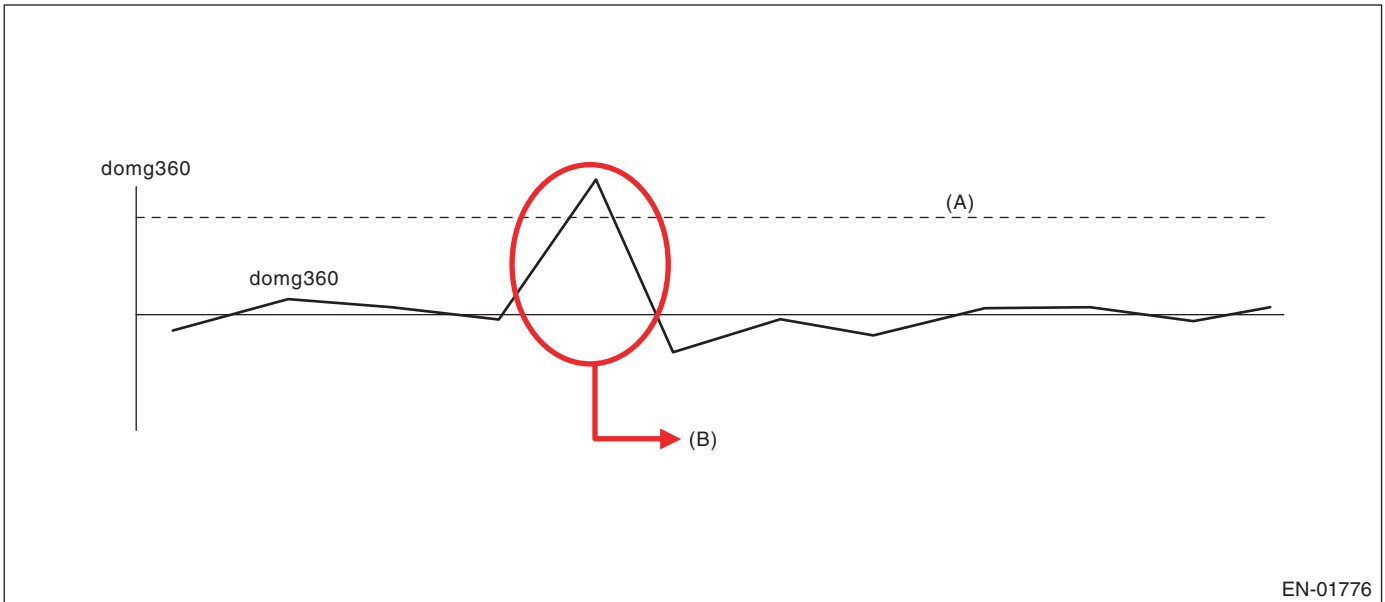

- (A) Threshold value
- (B) Judged as misfire

• 720° Interval Difference Method

Diagnosis value	$\text{domg } 720 = (\text{omg } 1 - \text{omg } 0) - (\text{omg } 7 - \text{omg } 6)$
Misfire judgment	$\text{domg } 720 > \text{judgment value} \rightarrow \text{Misfire occurs}$

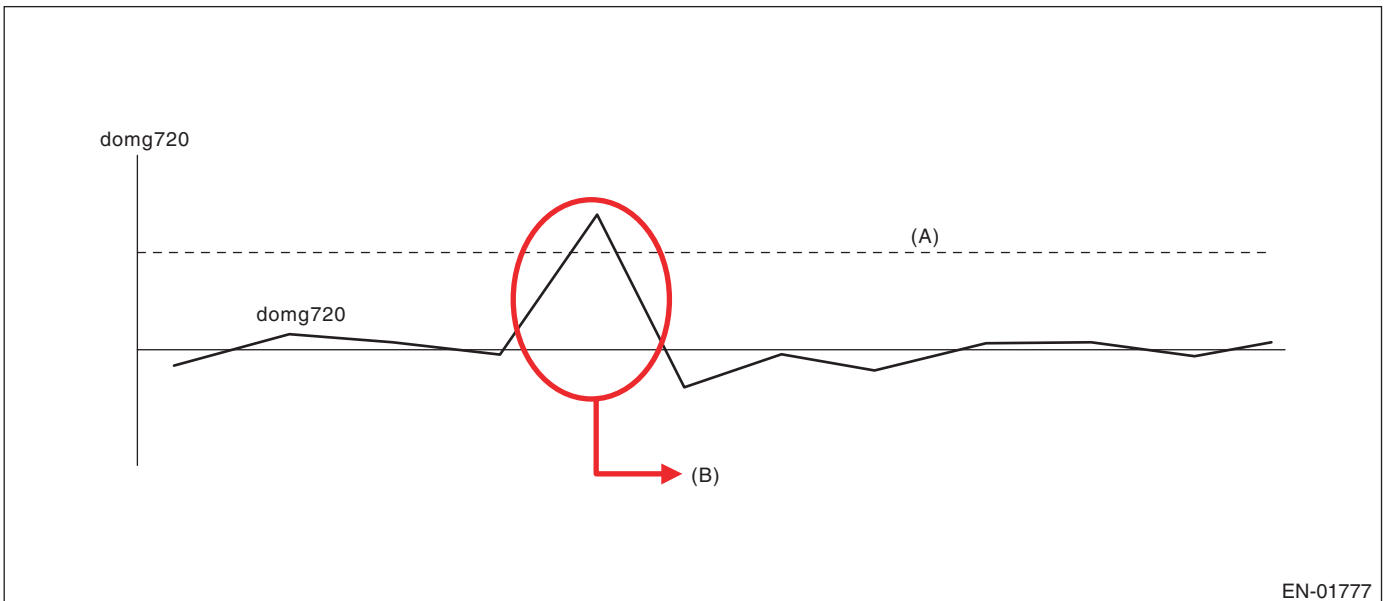

- (A) Threshold value
- (B) Judged as misfire

Diagnostic Trouble Code (DTC) Detecting Criteria

GENERAL DESCRIPTION

- FTP 1.5 times misfire (Misfire occurrence level affecting exhaust gas)

Judgment Value (Judge that malfunction occurs when the misfire ratio is high in 1,000 engine revs.)

Malfunction Criteria	Threshold Value
FTP emission judgment value	> 1.0% in 1,000 revs.

Time Needed for Diagnosis: 1,000 engine revs.

Malfunction Indicator Light Illumination: Illuminates when malfunction occurs in 2 continuous driving cycles.

- Catalyst damage misfire (Misfire occurrence level damaging catalyst)

Judgment Value (Judge that malfunction occurs when the misfire ratio is high in 200 engine revs. (400 ignitions))

Malfunction Criteria	Threshold Value
Catalyst damage misfire judgment value	See Map 1

Map 1 Fault criteria threshold for misfire which would result in catalyst damage

%	AIR INTAKE (g/rev.)										
	0.2	0.4	0.6	0.8	1.0	1.2	1.4	1.6	1.8	2.0	
ENGINE SPEED (rpm)	1000	37.0	32.0	28.5	26.0	23.0	21.3	21.3	-	-	-
	1500	35.0	29.5	25.5	22.5	21.3	21.3	21.3	18.0	-	-
	2000	32.0	22.5	22.5	18.3	14.5	10.8	10.0	9.0	8.0	5.0
	2500	29.0	21.8	14.3	11.3	9.8	9.0	8.5	8.0	7.5	5.0
	3000	27.0	21.8	14.5	9.8	9.0	9.0	8.0	7.5	7.0	5.0
	3500	24.5	18.5	10.8	6.8	5.8	5.5	5.0	5.0	5.0	5.0
	4000	-	15.3	10.0	6.8	5.5	5.0	5.0	5.0	5.0	5.0
	4500	-	13.8	8.5	6.3	5.0	5.0	5.0	5.0	5.0	-
	5000	-	13.8	8.5	5.8	5.0	5.0	5.0	5.0	5.0	-
	5500	-	13.5	8.3	5.5	5.0	5.0	5.0	5.0	5.0	-
	6000	-	13.0	8.0	5.3	5.0	5.0	5.0	5.0	5.0	-
	6500	-	12.5	7.5	5.0	5.0	5.0	5.0	5.0	-	-
6700	-	12.3	7.3	5.0	5.0	5.0	5.0	5.0	-	-	

EN-02282

These figures mean the misfire ratio (%) in 400 ignitions; for example, 22.5 (%) means 400 (ignition) × 22.5 (%) = 90 (ignition) or more, so this case is judged misfire.

Time Needed for Diagnosis: 200 engine revs.

Malfunction Indicator Light Illumination: Illuminates as soon as the malfunction occurs.

5. DTC CLEAR CONDITION

- When the OK idling cycle was completed 40 times in a row
- When "Clear Memory" was performed

6. MALFUNCTION INDICATOR LIGHT CLEAR CONDITION

- When the OK driving cycle was completed 3 times in a row
- When "Clear Memory" was performed

7. FAIL SAFE

None

Diagnostic Trouble Code (DTC) Detecting Criteria

GENERAL DESCRIPTION

8. ECM OPERATION AT DTC SETTING

Memorize the freeze frame data. (For test mode \$02)

AT:DTC P0302 CYLINDER 2 MISFIRE DETECTED

1. OUTLINE OF DIAGNOSIS

For the diagnostic procedure, refer to DTC P0301. <Ref. to GD(H4DOTC)-95, DTC P0301 CYLINDER 1 MISFIRE DETECTED, Diagnostic Trouble Code (DTC) Detecting Criteria.>

AU:DTC P0303 CYLINDER 3 MISFIRE DETECTED

1. OUTLINE OF DIAGNOSIS

For the diagnostic procedure, refer to DTC P0301. <Ref. to GD(H4DOTC)-95, DTC P0301 CYLINDER 1 MISFIRE DETECTED, Diagnostic Trouble Code (DTC) Detecting Criteria.>

AV:DTC P0304 CYLINDER 4 MISFIRE DETECTED

1. OUTLINE OF DIAGNOSIS

For the diagnostic procedure, refer to DTC P0301. <Ref. to GD(H4DOTC)-95, DTC P0301 CYLINDER 1 MISFIRE DETECTED, Diagnostic Trouble Code (DTC) Detecting Criteria.>

Diagnostic Trouble Code (DTC) Detecting Criteria

GENERAL DESCRIPTION

AW:DTC P0327 KNOCK SENSOR 1 CIRCUIT LOW INPUT (BANK 1 OR SINGLE SENSOR)

1. OUTLINE OF DIAGNOSIS

Detect the open or short circuit of the knock sensor. Judge NG when out of the standard value.

2. COMPONENT DESCRIPTION

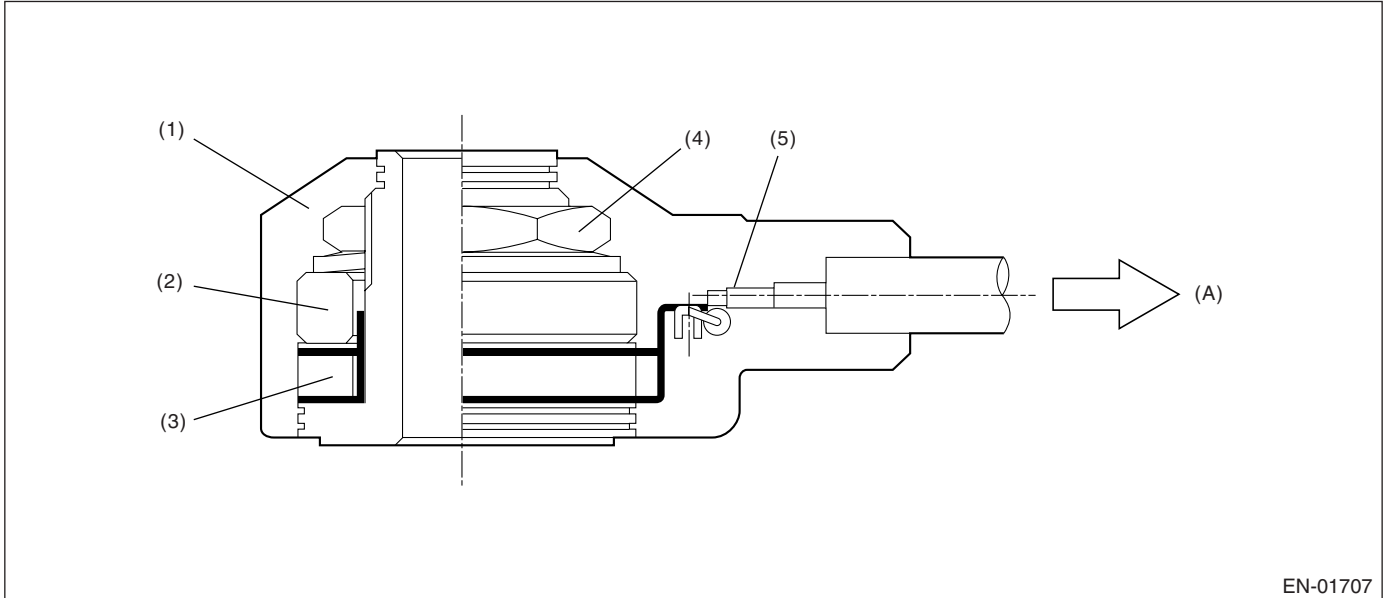

- (1) Case
- (2) Weight
- (3) Piezoelectric element
- (4) Nut
- (5) Resistance

(A) To knock sensor harness

3. ENABLE CONDITION

Secondary Parameters	Enable Conditions
None	

4. GENERAL DRIVING CYCLE

Always perform the diagnosis continuously.

5. DIAGNOSTIC METHOD

• Abnormality Judgment

Judge NG when the continuous time of completing the malfunction criteria below becomes more than 1 second.

Judgment Value

Malfunction Criteria	Threshold Value
Output voltage	< 0.238 V
Ignition switch	ON

Time Needed for Diagnosis: 1 second

Malfunction Indicator Light Illumination: Illuminates as soon as the malfunction occurs.

Diagnostic Trouble Code (DTC) Detecting Criteria

GENERAL DESCRIPTION

• Normality Judgment

Judge OK and clear NG when the malfunction criteria below are completed.

Judgment Value

Malfunction Criteria	Threshold Value
Output voltage	≥ 0.238 V
Ignition switch	ON

6. DTC CLEAR CONDITION

- When the OK idling cycle was completed 40 times in a row
- When "Clear Memory" was performed

7. MALFUNCTION INDICATOR LIGHT CLEAR CONDITION

- When the OK driving cycle was completed 3 times in a row
- When "Clear Memory" was performed

8. FAIL SAFE

Knock compensation:

- Knock compensation final timing advance and retard value = knock compensation + whole learning compensation value + partial learning compensation value.
- At normal: knock compensation = 0°CA is fixed.
- At trouble: knock compensation = -5°CA . (Retard 5°CA .)
- Not allowed to update the whole learning compensation factor.
- Not allowed to calculate the partial learning zone compensation value.

9. ECM OPERATION AT DTC SETTING

Memorize the freeze frame data. (For test mode \$02)

Diagnostic Trouble Code (DTC) Detecting Criteria

GENERAL DESCRIPTION

AX:DTC P0328 KNOCK SENSOR 1 CIRCUIT HIGH INPUT (BANK 1 OR SINGLE SENSOR)

1. OUTLINE OF DIAGNOSIS

Detect the open or short circuit of the knock sensor. Judge NG when out of the standard value.

2. COMPONENT DESCRIPTION

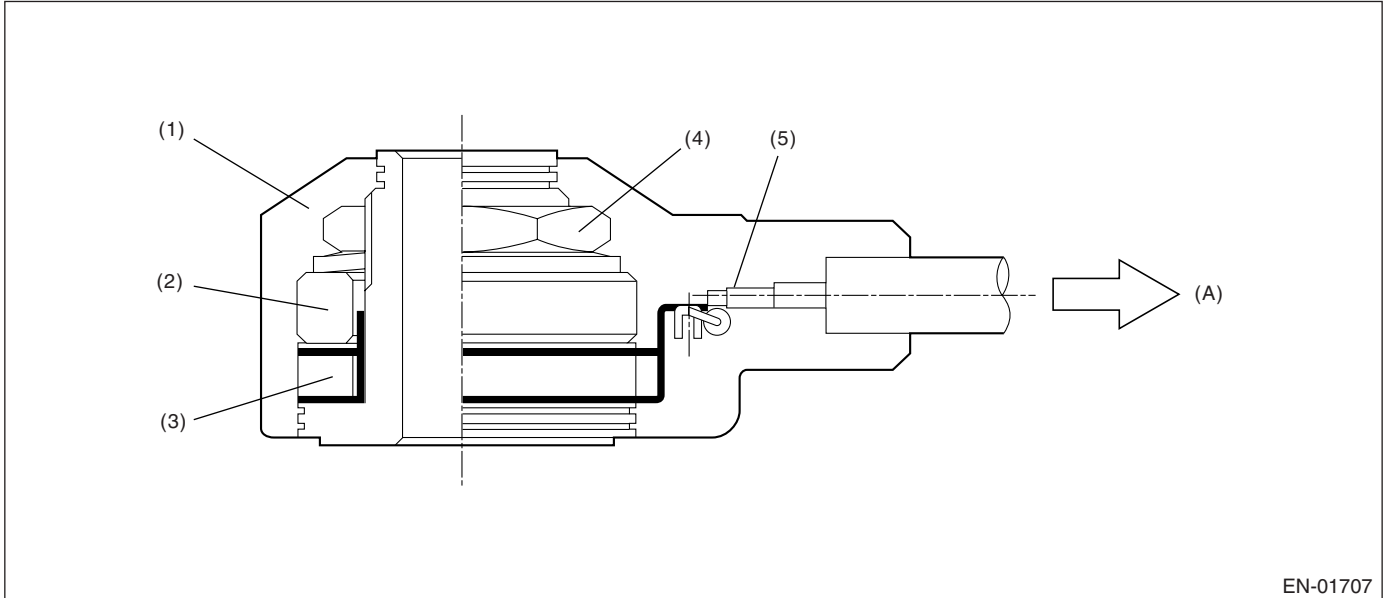

- (1) Case
- (2) Weight
- (3) Piezoelectric element
- (4) Nut
- (5) Resistance

(A) To knock sensor harness

3. ENABLE CONDITION

Secondary Parameters	Enable Conditions
None	

4. GENERAL DRIVING CYCLE

Always perform diagnosis continuously.

5. DIAGNOSTIC METHOD

• Abnormality Judgment

Judge NG when the continuous time of completing the malfunction criteria below becomes more than 1 second.

Judgment Value

Malfunction Criteria	Threshold Value
Output voltage	≥ 4.714 V
Ignition switch	ON

Time Needed for Diagnosis: 1 second

Malfunction Indicator Light Illumination: Illuminates as soon as the malfunction occurs.

Diagnostic Trouble Code (DTC) Detecting Criteria

GENERAL DESCRIPTION

• Normality Judgment

Judge OK and clear NG when the malfunction criteria below are completed.

Judgment Value

Malfunction Criteria	Threshold Value
Output voltage	< 4.714 V
Ignition switch	ON

6. DTC CLEAR CONDITION

- When the OK idling cycle was completed 40 times in a row
- When "Clear Memory" was performed

7. MALFUNCTION INDICATOR LIGHT CLEAR CONDITION

- When the OK driving cycle was completed 3 times in a row
- When "Clear Memory" was performed

8. FAIL SAFE

Knock compensation:

- Knock compensation final timing advance and retard value = knock compensation + whole learning compensation value + partial learning compensation value.
- At normal: knock compensation = 0°CA is fixed.
- At trouble: knock compensation = -5°CA. (Retard 5°CA.)
- Not allowed to update the whole learning compensation factor.
- Not allowed to calculate the partial learning zone compensation value.

9. ECM OPERATION AT DTC SETTING

Memorize the freeze frame data. (For test mode \$02)

Diagnostic Trouble Code (DTC) Detecting Criteria

GENERAL DESCRIPTION

AY:DTC P0335 CRANKSHAFT POSITION SENSOR "A" CIRCUIT

1. OUTLINE OF DIAGNOSIS

Detect the open or short circuit of crankshaft position sensor. Judge NG when the crankshaft signal does not input regardless of turning the starter.

2. COMPONENT DESCRIPTION

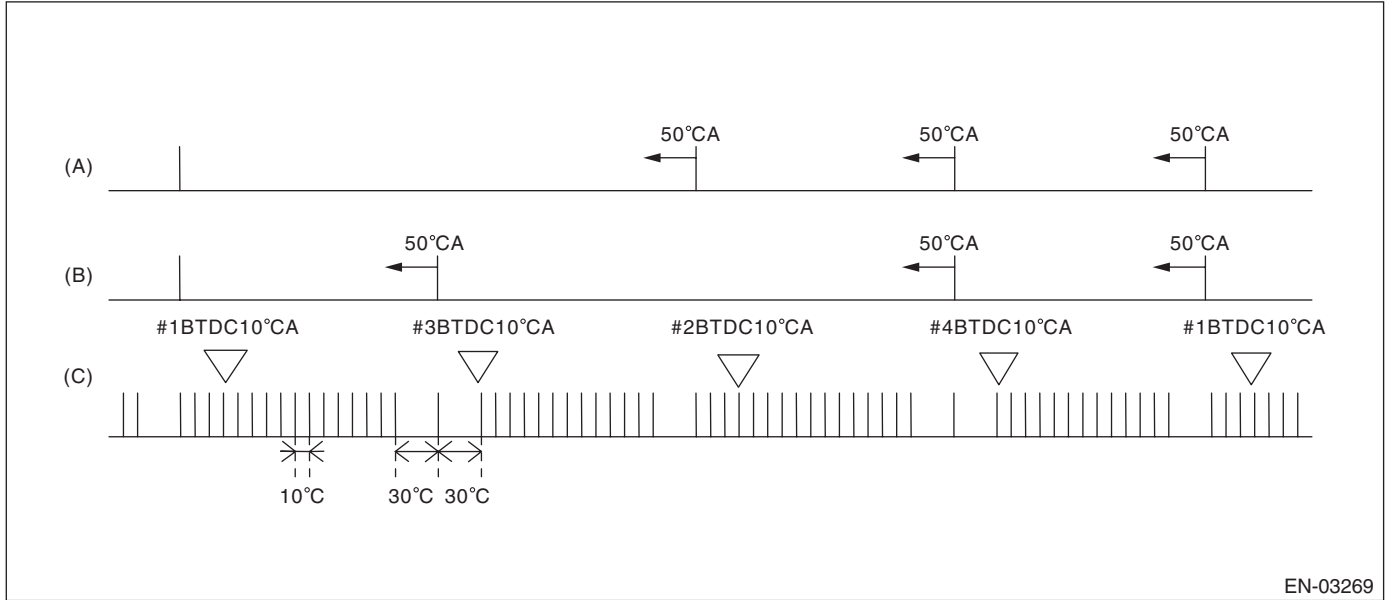

- (A) Camshaft signal RH
- (B) Camshaft signal LH
- (C) Crankshaft signal

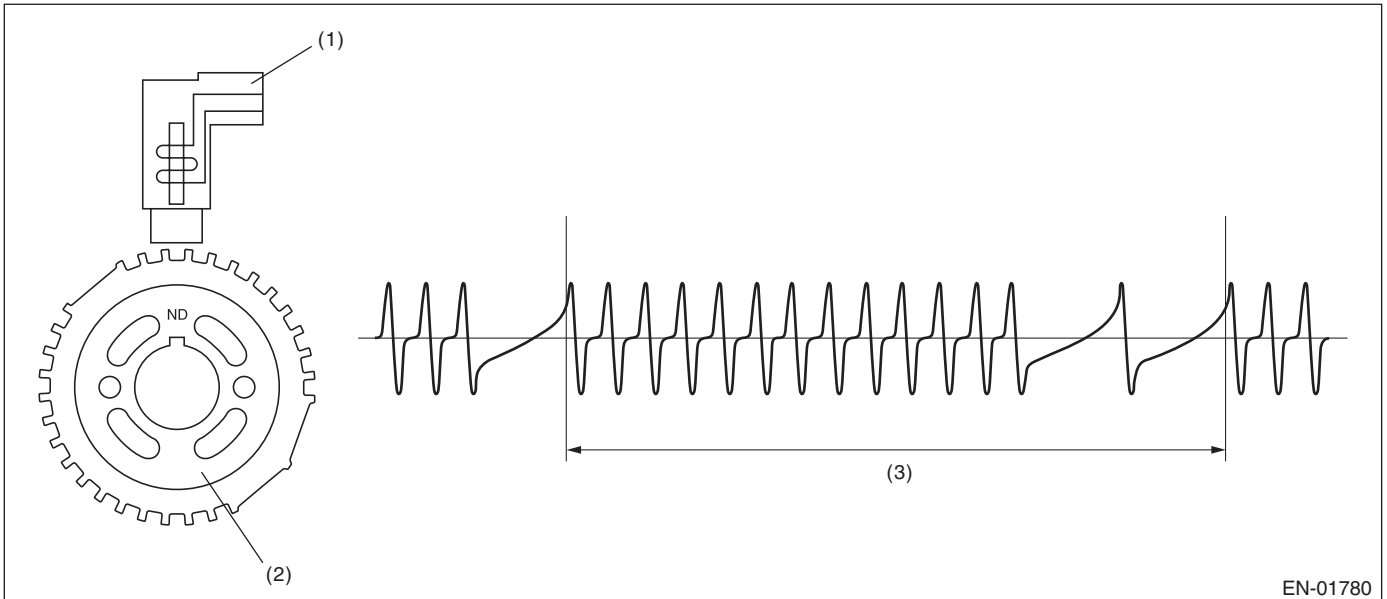

- (1) Crankshaft position sensor
- (2) Crank sprocket
- (3) Crankshaft half-turn

Diagnostic Trouble Code (DTC) Detecting Criteria

GENERAL DESCRIPTION

3. ENABLE CONDITION

Secondary Parameters	Enable Conditions
None	

4. GENERAL DRIVING CYCLE

Always perform the diagnosis continuously.

5. DIAGNOSTIC METHOD

• Abnormality Judgment

Judge NG when the continuous time of completing the malfunction criteria below becomes more than 3 seconds.

Judgment Value

Malfunction Criteria	Threshold Value
Starter switch	ON
Crankshaft position sensor signal	Not detected
Battery voltage	$\geq 8\text{ V}$

Time Needed for Diagnosis: 3 seconds

Malfunction Indicator Light Illumination: Illuminates as soon as the malfunction occurs.

• Normality Judgment

Judge OK when the continuous time of completing the malfunction criteria below becomes more than 3 seconds.

Judgment Value

Malfunction Criteria	Threshold Value
Crankshaft position sensor signal	Input exists
Battery voltage	$\geq 8\text{ V}$

6. DTC CLEAR CONDITION

- When the OK idling cycle was completed 40 times in a row
- When "Clear Memory" was performed

7. MALFUNCTION INDICATOR LIGHT CLEAR CONDITION

- When the OK driving cycle was completed 3 times in a row
- When "Clear Memory" was performed

8. FAIL SAFE

None

9. ECM OPERATION AT DTC SETTING

Memorize the freeze frame data. (For test mode \$02)

AZ:DTC P0336 CRANKSHAFT POSITION SENSOR "A" CIRCUIT RANGE/PERFORMANCE

1. OUTLINE OF DIAGNOSIS

Detect the malfunction of crankshaft position sensor output property. Judge NG when the number of crankshaft signal every 1 revolution becomes abnormal.

2. COMPONENT DESCRIPTION

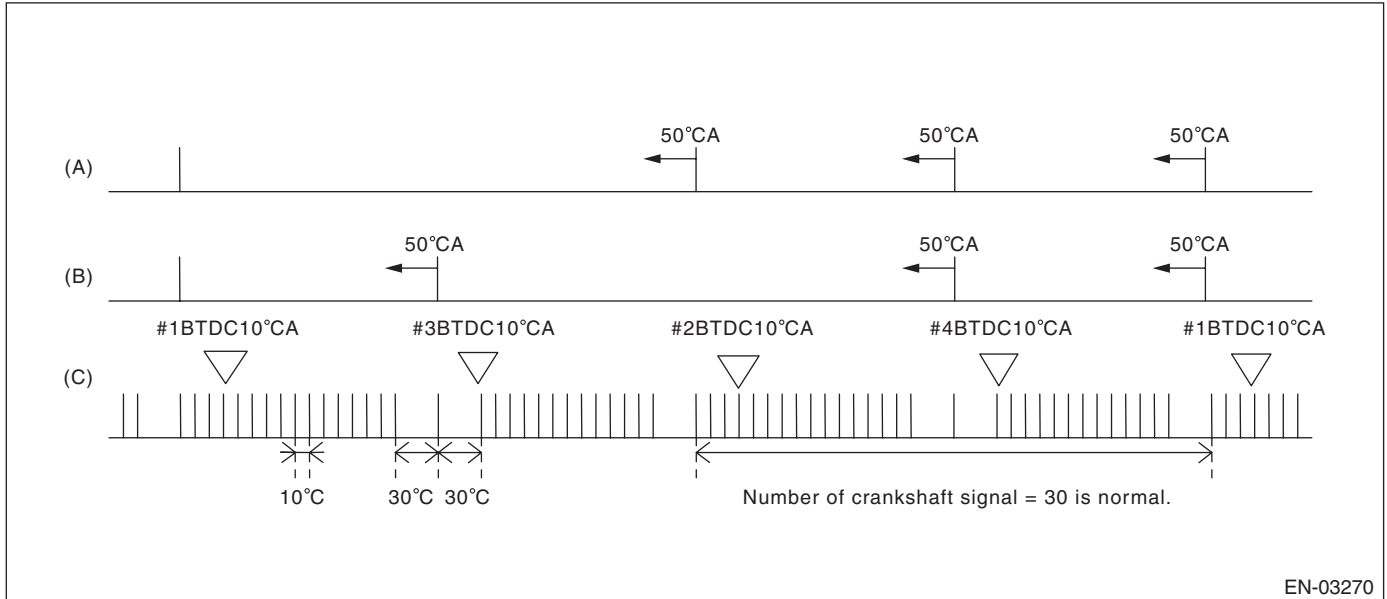

- (A) Camshaft signal RH
- (B) Camshaft signal LH
- (C) Crankshaft signal

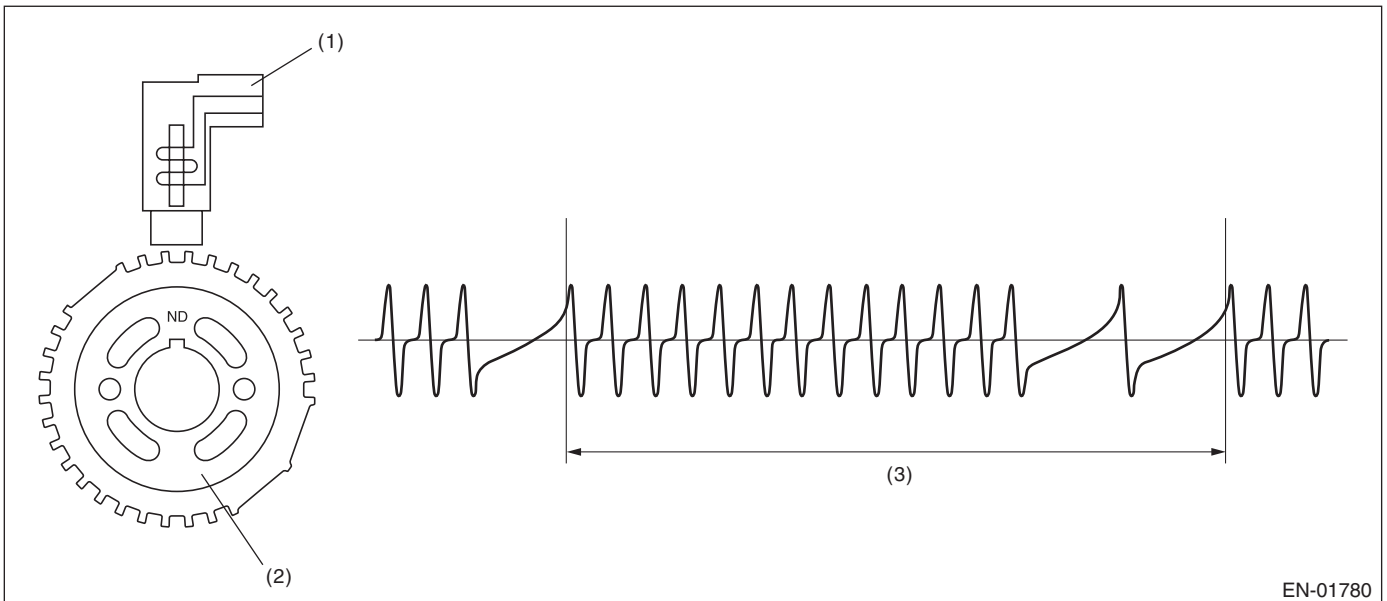

- (1) Crankshaft position sensor
- (2) Crank sprocket
- (3) Crankshaft half-turn

Diagnostic Trouble Code (DTC) Detecting Criteria

GENERAL DESCRIPTION

3. ENABLE CONDITION

Secondary Parameters	Enable Conditions
Battery voltage	$\geq 8\text{ V}$
Engine speed	$< 3,000\text{ rpm}$

4. GENERAL DRIVING CYCLE

Perform the diagnosis continuously under 3,000 rpm engine speed.

5. DIAGNOSTIC METHOD

• Abnormality Judgment

Judge NG when all the malfunction criteria below are completed more than 10 times in a row.

Judgment Value

Malfunction Criteria	Threshold Value
Cylinder number distinction	Completed
Amount of crank sensor signal during 1 rev.	Not = 30

Time Needed for Diagnosis: 10 engine revs.

Malfunction Indicator Light Illumination: Illuminates when malfunction occurs in 2 continuous driving cycles.

• Normality Judgment

Judge OK and clear the NG when the malfunction criteria below are completed.

Judgment Value

Malfunction Criteria	Threshold Value
Cylinder number distinction	Completed
Amount of crank sensor signal during 1 rev.	= 30

6. DTC CLEAR CONDITION

- When the OK idling cycle was completed 40 times in a row
- When "Clear Memory" was performed

7. MALFUNCTION INDICATOR LIGHT CLEAR CONDITION

- When the OK driving cycle was completed 3 times in a row
- When "Clear Memory" was performed

8. FAIL SAFE

None

9. ECM OPERATION AT DTC SETTING

Memorize the freeze frame data. (For test mode \$02)

Diagnostic Trouble Code (DTC) Detecting Criteria

GENERAL DESCRIPTION

BA:DTC P0340 CAMSHAFT POSITION SENSOR "A" CIRCUIT (BANK 1 OR SINGLE SENSOR)

1. OUTLINE OF DIAGNOSIS

Detect the open or short circuit of camshaft position sensor. Judge NG when the number of camshaft signal remains to be abnormal.

2. COMPONENT DESCRIPTION

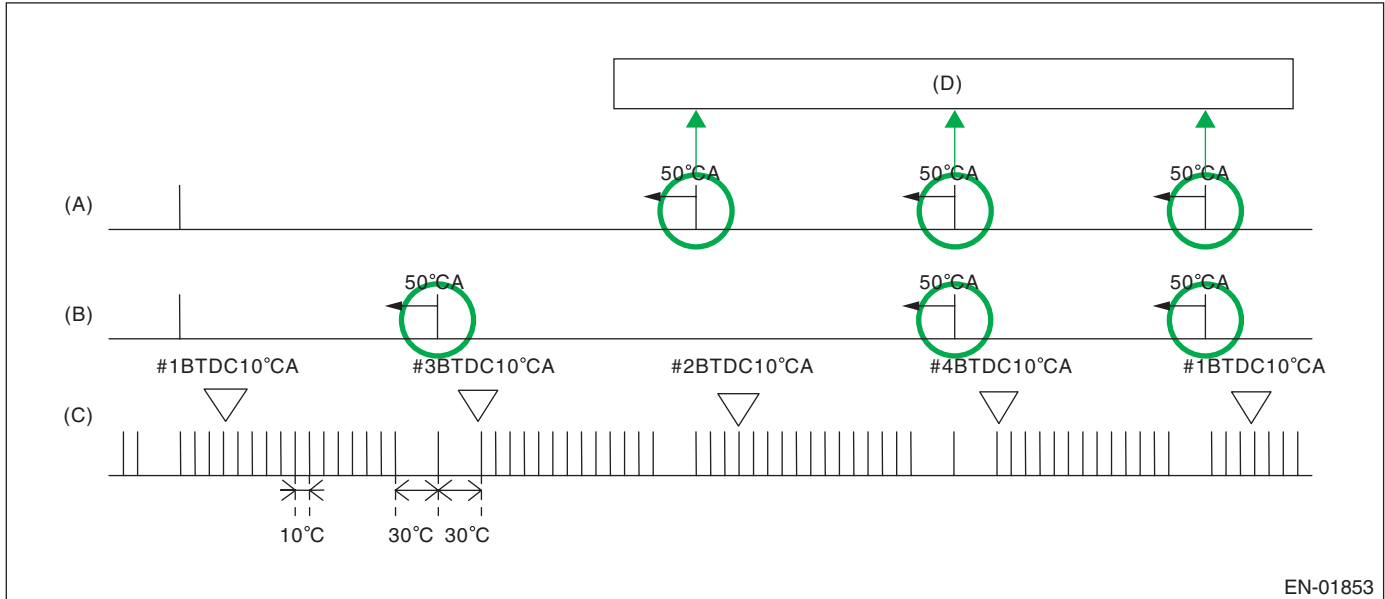

EN-01853

- (A) Camshaft signal RH
- (B) Camshaft signal LH
- (C) Crankshaft signal

- (D) Number of camshaft position signals = Receive camshaft position signal 3 times per tow engine revolutions.

3. ENABLE CONDITION

Secondary Parameters	Enable Conditions
Voltage	≥ 8 V

4. GENERAL DRIVING CYCLE

Always perform the diagnosis continuously.

5. DIAGNOSTIC METHOD

• Abnormality Judgment

The camshaft signal normally enters three times by two rev. of engine speed; however, judge NG when the camshaft signal does not enter three times continuously.

Judge NG when the malfunction criteria below are completed more than 100 rev. of engine speed. Judge OK and clear NG when the malfunction criteria below are not completed.

Judgment Value

Malfunction Criteria	Threshold Value
Number of camshaft sensor signal during 2 rev.	Except 3
Engine speed	≥ 600 rpm

Time Needed for Diagnosis: 100 rev.

Malfunction Indicator Light Illumination: Illuminates as soon as the malfunction occurs.

Diagnostic Trouble Code (DTC) Detecting Criteria

GENERAL DESCRIPTION

• Normality Judgment

Judge OK and clear the NG when the malfunction criteria below are completed.

Judgment Value

Malfunction Criteria	Threshold Value
Number of camshaft angle signal during 2 rev.	3

6. DTC CLEAR CONDITION

- When the OK idling cycle was completed 40 times in a row
- When “Clear Memory” was performed

7. MALFUNCTION INDICATOR LIGHT CLEAR CONDITION

- When the OK driving cycle was completed 3 times in a row
- When “Clear Memory” was performed

8. FAIL SAFE

- Ignition timing whole learning compensation:
 - Enter the initial value (whole learning compensation factor = 0.5, Variable amount of whole learning compensation factor = 0.25) to the whole learning compensation factor and variable amount of whole learning compensation factor when IG OFF, and then make the whole learning incomplete.
 - Enter the initial value (whole learning compensation factor = 0.5, Variable amount of whole learning compensation factor = 0.25) to the whole learning compensation factor and variable amount of whole learning compensation factor when making a normality judgment from abnormality judgment, and then make the whole learning incomplete.
- Ignition timing partial learning compensation:
 - Enter the initial value (0°C A) to the compensation value of partial learning zone when IG OFF.
 - Enter the initial value (0°C A) to the compensation value of partial learning zone when making a normality judgment from abnormality judgment.
- AVCS control:
 - Most timing retard learning is not complete or most timing retard learning completion is not experienced.
 - ISC feedback compensation: Do not perform the AVCS actual timing advance compensation.
 - Make the OCV driving Duty to be the given value (9.36%).

9. ECM OPERATION AT DTC SETTING

Memorize the freeze frame data. (For test mode \$02)

BB:DTC P0345 CAMSHAFT POSITION SENSOR “A” CIRCUIT (BANK 2)

NOTE:

For diagnostic procedure, refer to DTC P0340. <Ref. to GD(H4DOTC)-109, DTC P0340 CAMSHAFT POSITION SENSOR “A” CIRCUIT (BANK 1 OR SINGLE SENSOR), Diagnostic Trouble Code (DTC) Detecting Criteria.>

Diagnostic Trouble Code (DTC) Detecting Criteria

GENERAL DESCRIPTION

BC:DTC P0410 SECONDARY AIR INJECTION SYSTEM

1. OUTLINE OF DIAGNOSIS

Detect leakage or blocking of secondary air injection system.

When the secondary air injection system is operated (pump is ON, right and left combi valves are open), close right and left combi valves, and detect NG by the secondary air supply pipe pressure and flow amount of secondary air pipe.

2. ENABLE CONDITION

Secondary Parameters	Enable Conditions
Presumed ambient temperature	4.4°C (40°F)
Battery voltage	10.9 V
After secondary air injection system is operated	0.6 seconds
Battery voltage	7 V
Atmospheric pressure	563 mmHg
Engine	In operation
(Pressure measuring condition)	
Electric load change - after change (Air conditioning, power steering, lights, rear defroster, heater fan, radiator fan, neutral switch)	More than 5 seconds
Intake air amount	2 g (0.07 oz)/sec. or more and 15 g (0.53 oz)/sec. or less
Engine speed	≥ 800 rpm and ≤ 3,800 rpm
Vehicle speed	≤ 0 km/h
Canister purge duty	≥ 0%
Variable amount of engine speed at every 128 milliseconds	< 40rpm

3. GENERAL DRIVING CYCLE

Perform the diagnosis when the secondary air pump is operated.

4. DIAGNOSTIC METHOD

When the secondary air injection system is operated (pump is operated, right and left combi valves are open), close right and left combi valves respectively as following, and measure the secondary air supply pipe pressure and flow amount of secondary air pipe. Detect NG by 2 methods of pump supply pressure check and flow amount check.

Pump supply pressure check

Judge NG for the pump supply pressure when secondary air supply pipe pressure is lower than ambient pressure and judge OK when it is higher, when the secondary air pump is ON.

Flow amount check

When the secondary air injection system is operated (pump is operated, right and left combi valves are open), close right combi valve → close left combi valve → open right combi valve → open left combi valve, measure each secondary air supply pipe pressure (PSL, P0, PSR) and calculate the flow amount of secondary air pipe by these measurements. Detect NG according to flow amount of secondary air pipe.

Diagnostic Trouble Code (DTC) Detecting Criteria

GENERAL DESCRIPTION

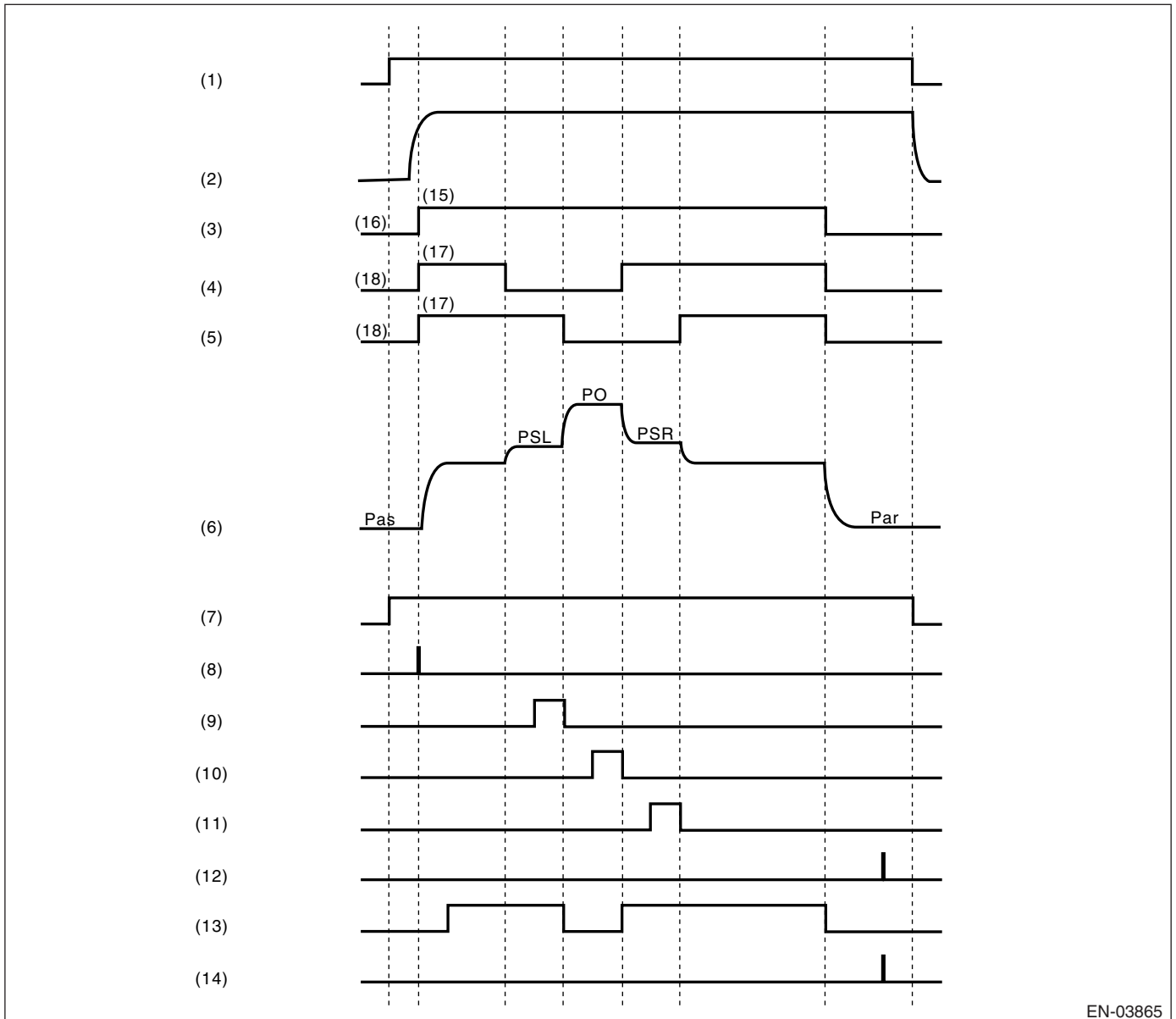

EN-03865

- | | | |
|---|---|-----------------------------------|
| (1) IG | (9) Right bank closure pressure (PSL) measurement | (14) Flow amount check (judgment) |
| (2) Ne | (10) Both banks closure pressure (PO) measurement | (15) ON |
| (3) Secondary air pump is operated | (11) Left bank closure pressure (PSR) measurement | (16) OFF |
| (4) E-COMB valve (right) status | (12) Ambient pressure after secondary air operation (Par) measurement | (17) Open |
| (5) E-COMB valve (left) status | (13) Pump supply pressure check (judgment) | (18) Closed |
| (6) Secondary air supply pipe pressure (psai) | | |
| (7) Diagnostic Enable Conditions | | |
| (8) Ambient pressure before secondary air operation (Pas) measurement | | |

Judgment Value

Judge NG when the malfunction criteria below are completed. Judge OK and clear the NG when the malfunction criteria below are not completed.

Diagnostic Trouble Code (DTC) Detecting Criteria

GENERAL DESCRIPTION

Pump supply pressure check

Malfunction Criteria	Threshold Value	DTC
Secondary air supply pipe relative pressure	< Value of Map 14	P0410

Map14

Unit: kPa (mmHg, inHg)		Ambient pressure (kPa (mmHg, inHg))							
		69.3 (520, 20.47)	74.6 (560, 22.03)	80.0 (600, 23.63)	85.3 (640, 25.19)	90.6 (680, 26.76)	96.0 (720, 28.35)	101.3 (760, 29.92)	106.6 (800, 31.48)
Battery voltage (V)	10.5	0.93 (7, 0.275)	0.93 (7, 0.275)	0.93 (7, 0.275)	0.93 (7, 0.275)	0.93 (7, 0.275)	0.93 (7, 0.275)	0.93 (7, 0.275)	0.93 (7, 0.275)
	11.5	0.93 (7, 0.275)	0.93 (7, 0.275)	0.93 (7, 0.275)	0.93 (7, 0.275)	0.93 (7, 0.275)	0.93 (7, 0.275)	0.93 (7, 0.275)	0.93 (7, 0.275)
	12.5	0.93 (7, 0.275)	0.93 (7, 0.275)	0.93 (7, 0.275)	0.93 (7, 0.275)	0.93 (7, 0.275)	0.93 (7, 0.275)	0.93 (7, 0.275)	0.93 (7, 0.275)
	13.5	0.93 (7, 0.275)	0.93 (7, 0.275)	0.93 (7, 0.275)	0.93 (7, 0.275)	0.93 (7, 0.275)	0.93 (7, 0.275)	0.93 (7, 0.275)	0.93 (7, 0.275)
	14.5	0.93 (7, 0.275)	0.93 (7, 0.275)	0.93 (7, 0.275)	0.93 (7, 0.275)	0.93 (7, 0.275)	0.93 (7, 0.275)	0.93 (7, 0.275)	0.93 (7, 0.275)
	15.5	0.93 (7, 0.275)	0.93 (7, 0.275)	0.93 (7, 0.275)	0.93 (7, 0.275)	0.93 (7, 0.275)	0.93 (7, 0.275)	0.93 (7, 0.275)	0.93 (7, 0.275)

Flow amount check

Malfunction Criteria	Threshold Value	DTC
Incorrect flow Presumed secondary air flow amount at bank 1 opened or Presumed secondary air flow amount at bank 2 opened Map (P0 vs PSL)	> Value of Map 20 > Value of Map 19	P0411
Bank 1 is stuck open Presumed secondary air flow amount at bank 1 opened and Both banks closure pressure	< Value of Map 16 < Value of Map 18	P2440
Bank 1 is stuck closed Presumed secondary air flow amount at bank 1 opened and Both banks closure pressure	< Value of Map 16 ≥ Value of Map 18	P2441
Bank 2 is stuck open Presumed secondary air flow amount at bank 2 opened and Both banks closure pressure	< Value of Map 15 < Value of Map 18	P2442
Bank 2 is stuck closed Presumed secondary air flow amount at bank 2 opened and Both banks closure pressure	< Value of Map 15 ≥ Value of Map 18	P2443

Diagnostic Trouble Code (DTC) Detecting Criteria

GENERAL DESCRIPTION

Map 15, Map 16

Unit: ℓ /min		Intake air flow (g (oz)/s)								
		7 (0.247)	8 (0.282)	9 (0.317)	10 (0.353)	11 (0.388)	12 (0.423)	13 (0.459)	14 (0.494)	15 (0.529)
Battery voltage (V)	11.0	4.1	1.0	1.0	1.0	1.0	1.0	1.0	1.0	1.0
	11.5	4.1	4.1	1.0	1.0	1.0	1.0	1.0	1.0	1.0
	12.0	4.1	4.1	4.1	1.0	1.0	1.0	1.0	1.0	1.0
	12.5	10.0	10.0	10.0	4.1	4.1	4.1	1.0	1.0	1.0
	13.0	17.5	17.5	17.5	10.0	10.0	10.0	4.1	1.0	1.0
	13.5	17.5	17.5	17.5	17.5	17.5	17.5	17.5	4.1	4.1
	14.0	17.5	17.5	17.5	17.5	17.5	17.5	17.5	10.0	10.0
	14.5	17.5	17.5	17.5	17.5	17.5	17.5	17.5	10.0	10.0

Map 18

Unit: kPa (mmHg, inHg)		Ambient pressure (kPa (mmHg, inHg))							
		69.3 (520, 20.47)	74.6 (560, 22.03)	80.0 (600, 23.63)	85.3 (640, 25.19)	90.6 (680, 26.76)	96.0 (720, 28.35)	101.3 (760, 29.92)	106.6 (800, 31.48)
Battery voltage (V)	10.5	78.0 (585, 23.03)	84.0 (630, 24.80)	90.0 (675, 26.58)	96.0 (720, 28.35)	102.0 (765, 30.13)	108.0 (810, 31.90)	114.0 (855, 33.67)	120.0 (900, 35.44)
	11.5	79.3 (595, 23.42)	85.4 (641, 25.22)	91.6 (687, 27.05)	97.7 (733, 28.86)	103.7 (778, 30.63)	109.8 (824, 32.43)	116.0 (870, 34.26)	122.1 (916, 36.06)
	12.5	80.8 (606, 23.86)	86.9 (652, 25.67)	93.2 (699, 27.53)	99.3 (745, 29.33)	105.6 (792, 31.19)	111.7 (838, 32.99)	118.0 (885, 34.85)	124.2 (932, 36.68)
	13.5	82.1 (616, 24.25)	88.4 (663, 26.11)	94.8 (711, 28.0)	101.0 (758, 29.83)	107.3 (805, 31.69)	113.7 (853, 33.58)	120.0 (900, 35.44)	126.2 (947, 37.27)
	14.5	83.4 (626, 24.63)	89.8 (674, 26.52)	96.2 (722, 28.41)	102.8 (771, 30.36)	109.2 (819, 32.25)	115.6 (867, 34.14)	122.0 (915, 36.03)	128.4 (963, 37.92)
	15.5	84.8 (636, 25.05)	89.8 (685, 26.52)	97.8 (734, 28.89)	104.4 (783, 30.83)	110.9 (832, 32.75)	117.4 (881, 34.67)	124.0 (930, 36.62)	130.5 (979, 38.54)

Map 19, Map 20

Unit: ℓ /min		Intake air flow (g (oz)/s)								
		2.0 (0.071)	4.0 (0.141)	6.0 (0.212)	8.0 (0.282)	10.0 (0.353)	12.0 (0.423)	14.0 (0.494)	16.0 (0.564)	18.0 (0.635)
Battery voltage (V)	10.5	290	290	290	290	290	290	290	290	290
	11.5	330	330	330	330	330	330	330	330	330
	12.5	370	370	370	370	370	370	370	370	370
	13.5	420	420	420	420	420	420	420	420	420
	14.5	470	470	470	470	470	470	470	470	470
	15.5	520	520	520	520	520	520	520	520	520

Time Needed for Diagnosis: 7 seconds

Malfunction Indicator Light Illumination: Illuminates when malfunction occurs in 2 continuous driving cycles.

5. DTC CLEAR CONDITION

- When the OK idling cycle was completed 40 times in a row
- When "Clear Memory" was performed

Diagnostic Trouble Code (DTC) Detecting Criteria

GENERAL DESCRIPTION

6. MALFUNCTION INDICATOR LIGHT CLEAR CONDITION

- When the OK driving cycle was completed 3 times in a row
- When "Clear Memory" was performed

7. FAIL SAFE

None

8. ECM OPERATION AT DTC SETTING

- Memorize the freeze frame data. (For test mode \$02)
- Memorize the diagnostic value and trouble standard value. (For test mode \$06)

BD:DTC P0411 SECONDARY AIR INJECTION SYSTEM INCORRECT FLOW DETECTED

NOTE:

For the diagnostic procedure, refer to DTC P0410. <Ref. to GD(H4DOTC)-111, DTC P0410 SECONDARY AIR INJECTION SYSTEM, Diagnostic Trouble Code (DTC) Detecting Criteria.>

Diagnostic Trouble Code (DTC) Detecting Criteria

GENERAL DESCRIPTION

BE:DTC P0413 SECONDARY AIR INJECTION SYSTEM SWITCHING VALVE "A" CIRCUIT OPEN

1. OUTLINE OF DIAGNOSIS

Judge NG when the ECM output level is different from the actual terminal level.

2. ENABLE CONDITION

Secondary Parameters	Enable Conditions
OFF	

3. GENERAL DRIVING CYCLE

Always perform the diagnosis continuously.

4. DIAGNOSTIC METHOD

• Abnormality Judgment

Judge NG when the continuous time of completing the malfunction criteria below becomes more than 2.5 seconds.

Judgment Value

Malfunction Criteria	Threshold Value
Battery voltage	≥ 10.9 V
Ignition	ON
Terminal voltage when ECM transmits OFF signal	Low

Time Needed for Diagnosis: 2.5 seconds

Malfunction Indicator Light Illumination: Illuminates when malfunction occurs.

• Normality Judgment

Judge OK and clear the NG when the malfunction criteria below are completed.

Judgment Value

Malfunction Criteria	Threshold Value
Battery voltage	≥ 10.9 V
Ignition	ON
Terminal voltage when ECM transmits OFF signal	High

5. DTC CLEAR CONDITION

- When the OK idling cycle was completed 40 times in a row
- When "Clear Memory" was performed

6. MALFUNCTION INDICATOR LIGHT CLEAR CONDITION

- When the OK driving cycle was completed 3 times in a row
- When "Clear Memory" was performed

7. FAIL SAFE

None

8. ECM OPERATION AT DTC SETTING

Memorize the freeze frame data. (For test mode \$02)

Diagnostic Trouble Code (DTC) Detecting Criteria

GENERAL DESCRIPTION

BF:DTC P0414 SECONDARY AIR INJECTION SYSTEM SWITCHING VALVE "A" CIRCUIT SHORTED

1. OUTLINE OF DIAGNOSIS

Judge NG when the ECM output level is different from the actual terminal level.

2. ENABLE CONDITION

Secondary Parameters	Enable Conditions
OFF	

3. GENERAL DRIVING CYCLE

Always perform the diagnosis continuously.

4. DIAGNOSTIC METHOD

• Abnormality Judgment

Judge NG when the continuous time of completing the malfunction criteria below becomes more than 2.5 seconds.

Judgment Value

Malfunction Criteria	Threshold Value
Battery voltage	≥ 10.9 V
Ignition	ON
Terminal voltage when ECM transmits ON signal	High

Time Needed for Diagnosis: 2.5 seconds

Malfunction Indicator Light Illumination: Illuminates when malfunction occurs.

• Normality Judgment

Judge OK and clear the NG when the malfunction criteria below are completed.

Judgment Value

Malfunction Criteria	Threshold Value
Battery voltage	≥ 10.9 V
Ignition	ON
Terminal voltage when ECM transmits ON signal	Low

5. DTC CLEAR CONDITION

- When the OK idling cycle was completed 40 times in a row
- When "Clear Memory" was performed

6. MALFUNCTION INDICATOR LIGHT CLEAR CONDITION

- When the OK driving cycle was completed 3 times in a row
- When "Clear Memory" was performed

7. FAIL SAFE

None

8. ECM OPERATION AT DTC SETTING

Memorize the freeze frame data. (For test mode \$02)

Diagnostic Trouble Code (DTC) Detecting Criteria

GENERAL DESCRIPTION

BG:DTC P0416 SECONDARY AIR INJECTION SYSTEM SWITCHING VALVE “B” CIRCUIT OPEN

NOTE:

For the diagnostic procedure, refer to DTC P0413. <Ref. to GD(H4DOTC)-116, DTC P0413 SECONDARY AIR INJECTION SYSTEM SWITCHING VALVE “A” CIRCUIT OPEN, Diagnostic Trouble Code (DTC) Detecting Criteria.>

BH:DTC P0417 SECONDARY AIR INJECTION SYSTEM SWITCHING VALVE “B” CIRCUIT SHORTED

NOTE:

For the diagnostic procedure, refer to DTC P0414. <Ref. to GD(H4DOTC)-117, DTC P0414 SECONDARY AIR INJECTION SYSTEM SWITCHING VALVE “A” CIRCUIT SHORTED, Diagnostic Trouble Code (DTC) Detecting Criteria.>

Diagnostic Trouble Code (DTC) Detecting Criteria

GENERAL DESCRIPTION

BI: DTC P0418 SECONDARY AIR INJECTION SYSTEM CONTROL "A" CIRCUIT OPEN

1. OUTLINE OF DIAGNOSIS

Judge NG when the ECM output level is different from the actual terminal level.

2. ENABLE CONDITION

Secondary Parameters	Enable Conditions
OFF	

3. GENERAL DRIVING CYCLE

Always perform the diagnosis continuously.

4. DIAGNOSTIC METHOD

• Abnormality Judgment

Judge NG when the continuous time of completing the malfunction criteria below becomes more than 2.5 seconds.

Judgment Value

Malfunction Criteria	Threshold Value
Battery voltage	≥ 10.9 V
Ignition	ON
Terminal voltage when ECM transmits OFF signal	Low

Time Needed for Diagnosis: 2.5 seconds

Malfunction Indicator Light Illumination: Illuminates when malfunction occurs.

• Normality Judgment

Judge OK and clear the NG when the malfunction criteria below are completed.

Judgment Value

Malfunction Criteria	Threshold Value
Battery voltage	≥ 10.9 V
Ignition	ON
Terminal voltage when ECM transmits OFF signal	High

5. DTC CLEAR CONDITION

- When the OK idling cycle was completed 40 times in a row
- When "Clear Memory" was performed

6. MALFUNCTION INDICATOR LIGHT CLEAR CONDITION

- When the OK driving cycle was completed 3 times in a row
- When "Clear Memory" was performed

7. FAIL SAFE

None

8. ECM OPERATION AT DTC SETTING

Memorize the freeze frame data. (For test mode \$02)

Diagnostic Trouble Code (DTC) Detecting Criteria

GENERAL DESCRIPTION

BJ:DTC P0420 CATALYST SYSTEM EFFICIENCY BELOW THRESHOLD (BANK 1)

1. OUTLINE OF DIAGNOSIS

Detect the deterioration of catalyst function.

Though the rear oxygen sensor output would change slowly with a new catalyst, the sensor output with a deteriorated catalyst becomes high and the inversion time is shortened. For this reason, the catalyst diagnosis is carried out by monitoring the rear oxygen sensor output and comparing it with the front A/F sensor output.

2. COMPONENT DESCRIPTION

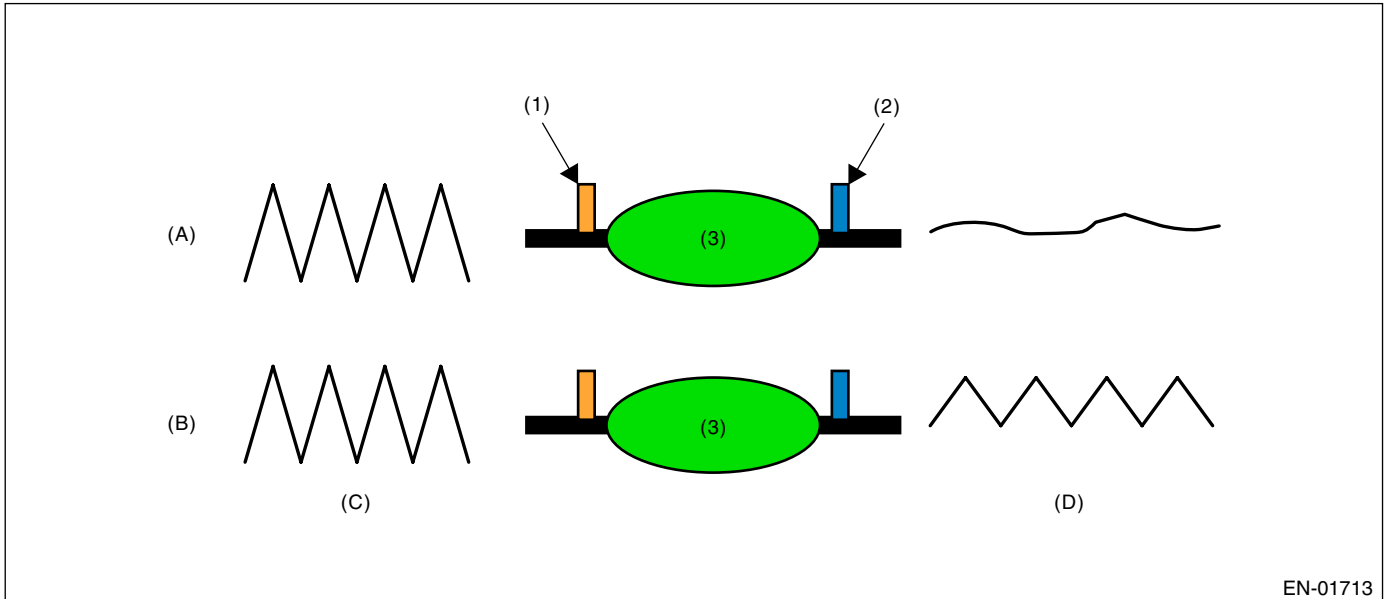

EN-01713

- (1) Front oxygen (A/F) sensor
- (2) Rear oxygen sensor
- (3) Catalyst

- (A) Normal
- (B) Deterioration
- (C) Front oxygen (A/F) sensor waveform
- (D) Rear oxygen sensor waveform

Diagnostic Trouble Code (DTC) Detecting Criteria

GENERAL DESCRIPTION

3. ENABLE CONDITION

Secondary Parameters	Enable Conditions
Battery voltage	> 10.9 V
Atmospheric pressure	> 75.0 kPa (563 mmHg, 22.2 inHg)
Engine coolant temperature	≥ 70°C (158°F)
Catalyst warm-up counter on Map 2	≥ 8,000
Misfire detection during 200 engine revs.	< 5 times
Learning value of evaporation gas density	< 0.20
Sub feedback	Operating
Evaporative system diagnostic	Not in operation
Difference between actual and target time lambda < 0.10	1,000 milliseconds or more
Vehicle speed	≥ 70 km/h (47 MPH)
Amount of intake air	12 ↔ 40 g/s
Engine load change every 0.5 engine revs.	< 0.02 g/rev
Rear O ₂ output change from below 660 mV to over	Experienced after fuel cut
After engine starting	≥ 235 seconds
Purge execution cumulative time after engine starting	≥ 19.9 seconds

• Map 2

Add the following value every 512 milliseconds.

Catalyst warm-up counter ≤ 9,000

Amount of intake air (g/s)	0	5	7.5	10	15	20	25	30	35	40	45	50
Integrated value for warm-up counter	-5	-5	1	11	25	40	57	72	87	100	100	100

Catalyst warm-up counter > 9,000

Amount of intake air (g/s)	0	5	7.5	10	15	20	25	30	35	40	45	50
Integrated value for warm-up counter	-16	-8	-1	3	6	8	9	11	13	14	14	14

4. GENERAL DRIVING CYCLE

Perform the diagnosis once at the constant vehicle speed of 75 km/h (47 MPH) or more after warming up the engine.

5. DIAGNOSTIC METHOD

After the malfunction criteria are completed, calculate the output fluctuation value of front oxygen (A/F) sensor and output fluctuation value of rear oxygen sensor.

Calculate the diagnosis value when the front oxygen (A/F) sensor output fluctuation value more than specified value.

Regard the A/F response properties and diagnosis value as parameters for judgment value.

Judge NG when the malfunction criteria below are completed, and judge OK when they are not completed.

Diagnostic Trouble Code (DTC) Detecting Criteria

GENERAL DESCRIPTION

Judgment Value

Malfunction Criteria	Threshold Value
Accumulated variation of output voltage of rear oxygen sensor per 32 milliseconds divided by accumulated variation of lambda of front oxygen (A/F) sensor per 32 milliseconds	≥ 12.6

Time Needed for Diagnosis: 33 — 55 seconds

Malfunction Indicator Light Illumination: Illuminates when malfunction occurs in 2 continuous driving cycles.

6. DTC CLEAR CONDITION

- When the OK idling cycle was completed 40 times in a row
- When “Clear Memory” was performed

7. MALFUNCTION INDICATOR LIGHT CLEAR CONDITION

- When the OK driving cycle was completed 3 times in a row
- When “Clear Memory” was performed

8. FAIL SAFE

None

9. ECM OPERATION AT DTC SETTING

- Memorize the freeze frame data. (For test mode \$02)
- Memorize the diagnostic value and trouble standard value. (For test mode \$06)

BK:DTC P0442 EVAPORATIVE EMISSION CONTROL SYSTEM LEAK DETECTED (SMALL LEAK)

1. OUTLINE OF DIAGNOSIS

Perform the diagnosis of leakage of fuels system and valve functions.

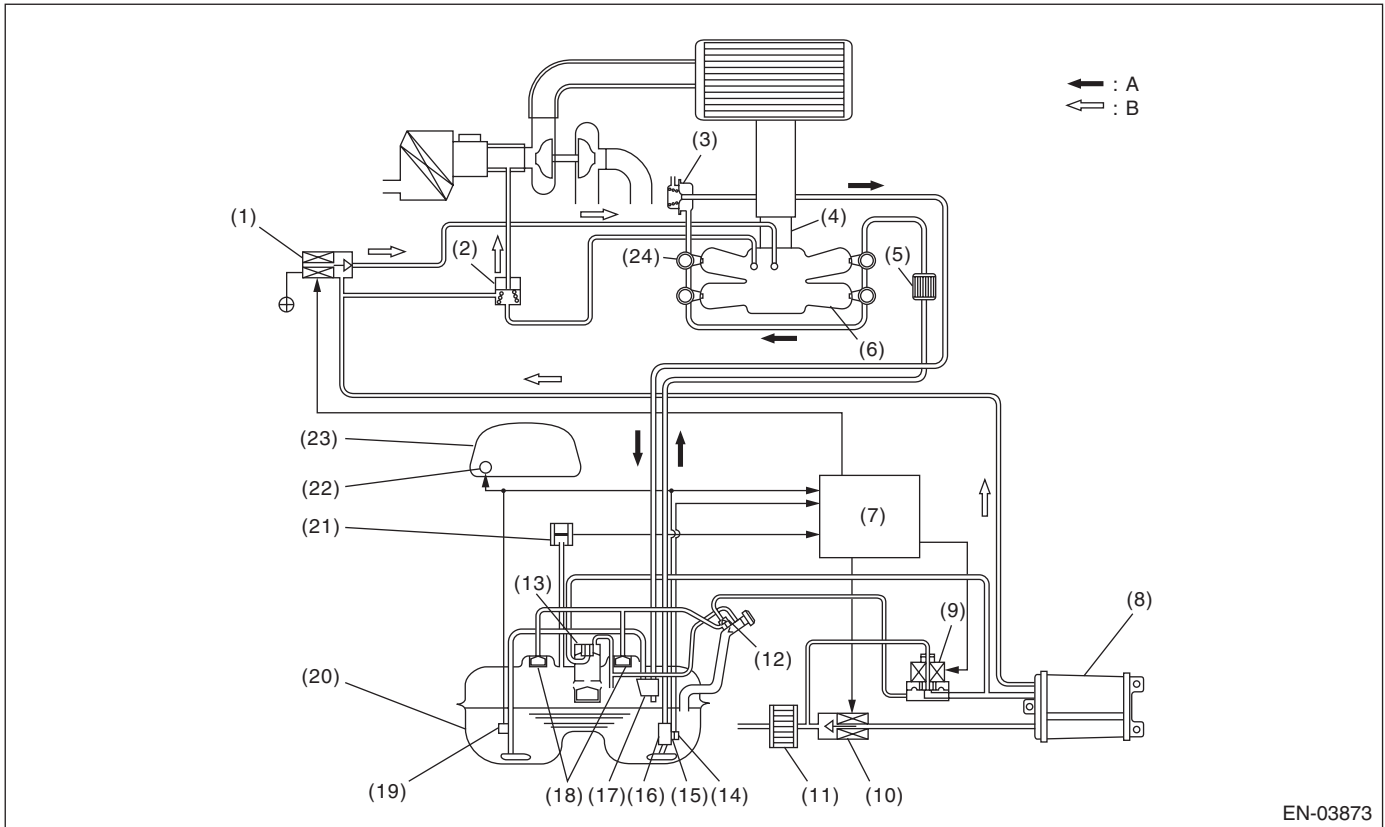

EN-03873

- | | | |
|-------------------------------------|------------------------------|--------------------------------|
| (1) Purge control solenoid valve | (10) Drain valve | (19) Fuel sub level sensor |
| (2) Purge valve | (11) Drain filter | (20) Fuel tank |
| (3) Pressure regulator | (12) Shut-off valve | (21) Fuel tank pressure sensor |
| (4) Throttle body | (13) Vent valve | (22) Fuel gauge |
| (5) Fuel filter | (14) Fuel temperature sensor | (23) Combination meter |
| (6) Intake manifold | (15) Fuel level sensor | (24) Fuel injector |
| (7) Engine control module (ECM) | (16) Fuel pump | (A) Fuel line |
| (8) Canister | (17) Jet pump | (B) Evaporation fuel line |
| (9) Pressure control solenoid valve | (18) Fuel cut valve | |

In this system diagnosis, filter tank pressure is changed. And leakage and normality & abnormality of valve operation are judged by monitoring the pressure change status using the fuel tank pressure sensor. The diagnosis is performed for 0.04-inch diagnosis in the order of Mode A, Mode B, Mode C and Mode D. For 0.02-inch diagnosis, perform in the order of Mode Y, Mode A, Mode B, Mode C and Mode D.

Diagnostic Trouble Code (DTC) Detecting Criteria

GENERAL DESCRIPTION

0.04-inch Diagnosis

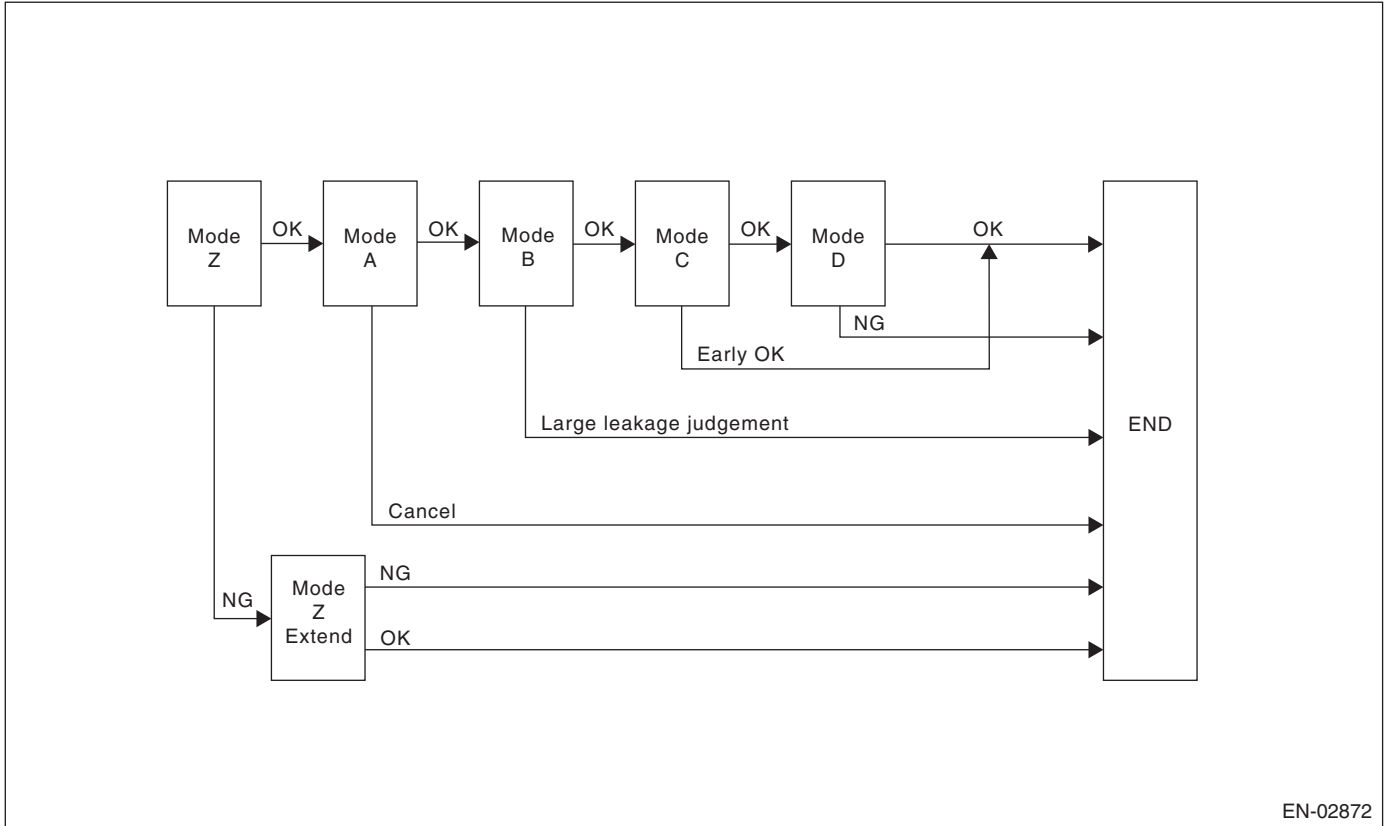

EN-02872

Mode	Mode Description	Diagnosis Period
Mode Z (Purge control solenoid valve open fail diagnosis)	Perform the diagnosis of purge control solenoid valve open fail depending on the magnitude of the tank pressure change after diagnosis started.	3 — 16 seconds
Mode A (Evaluation of EVAP. generation amount)	Calculate the tank pressure change amount (P1).	10 seconds
Mode B (Negative pressure sealed/large leak judgment)	Introduce the intake manifold pressure into the fuel tank. If the tank pressure cannot be reduced, diagnose that there is large leakage.	5 — 25 seconds
Mode C (Pressure increase check/premature OK judgment)	Wait until the tank pressure returns to the target value (Tank pressure when P2 calculation started). If the pressure does not return, perform the premature OK judgment.	1 — 15 seconds
Mode D (Negative pressure change amount measurement/EVAP. leakage diagnosis)	Calculate the tank pressure change amount (P2), and measure the diagnosis value using P1 calculated in Mode A. Perform the EVAP. leakage diagnosis using the diagnosis value.	10 seconds

Mode table for Evaporative Emission Control System diagnosis

Mode	Normal conditions	Diagnostic item	DTC
Mode Z	Nearly same as atmospheric pressure (equivalent pressure of 0 kPa (0 mmHg, 0 inHg))	Purge control solenoid valve is judged to be open.	P0457
Mode A	Pressure is in proportion to amount of evaporative emission.	—	—
Mode B	Negative pressure is formed due to intake manifold negative pressure	Large leak	P0457
Mode C	Target pressure is reached.	—	—
Mode D	Pressure change is small.	EVAP system is judged to have large leak [1.0 mm (0.04 in)].	P0442

Diagnostic Trouble Code (DTC) Detecting Criteria

GENERAL DESCRIPTION

0.02-inch Diagnosis

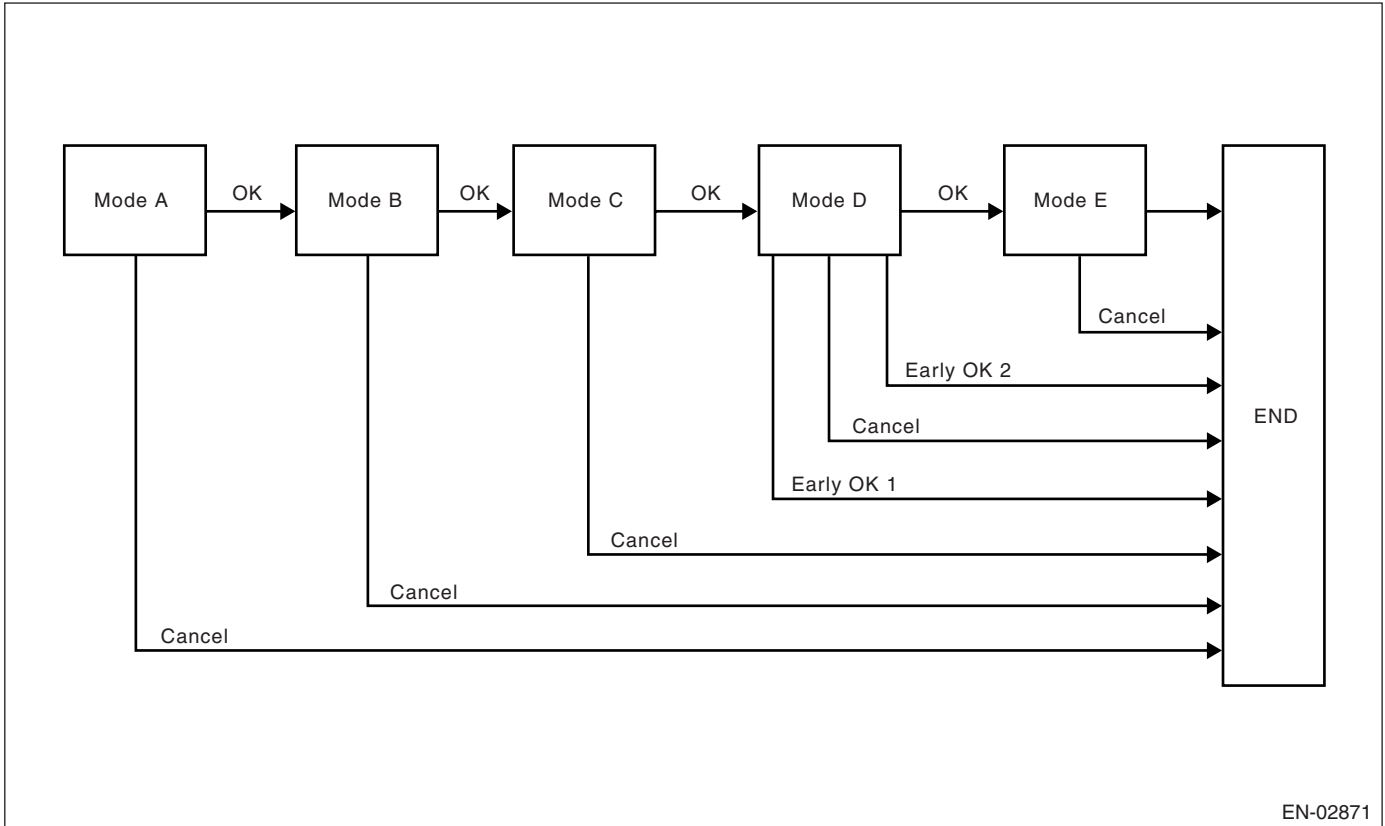

Mode	Mode Description	Diagnosis Period
Mode A (0 point correction)	Wait until the tank pressure returns to 0 point (around 0 mmHg) when tank pressure is high.	0 — 12 seconds
Mode B (Introduce negative pressure)	Introduce the intake manifold pressure to the fuel tank and reduce the tank pressure to the desired value.	0 — 27 seconds
Mode C (Maintain negative pressure)	Wait until the tank pressure returns to target pressure (start pressure of P2 calculation).	0 — 20 seconds
Mode D (Calculation of negative pressure variation)	Calculate the time until the tank pressure returns the end pressure of P2 calculation. Make advanced OK judgment when the tank pressure does not return the end pressure of P2 calculation.	0 — 200 seconds
Mode E (Calculation of Evaporative gas yield)	Calculate the amount of evaporative gas yield (P1).	0 — 280 seconds

Diagnostic Trouble Code (DTC) Detecting Criteria

GENERAL DESCRIPTION

2. COMPONENT DESCRIPTION

• Pressure Control Solenoid Valve

Pressure control solenoid valve maintains the fuel tank pressure equal to the atmospheric air pressure. Normally, the solenoid is set to OFF, and the valve mechanically opens and closes in accordance with the difference between the tank pressure and atmospheric air pressure, and the tank pressure and canister pressure.

The solenoid which is set to ON forces to open the valve.

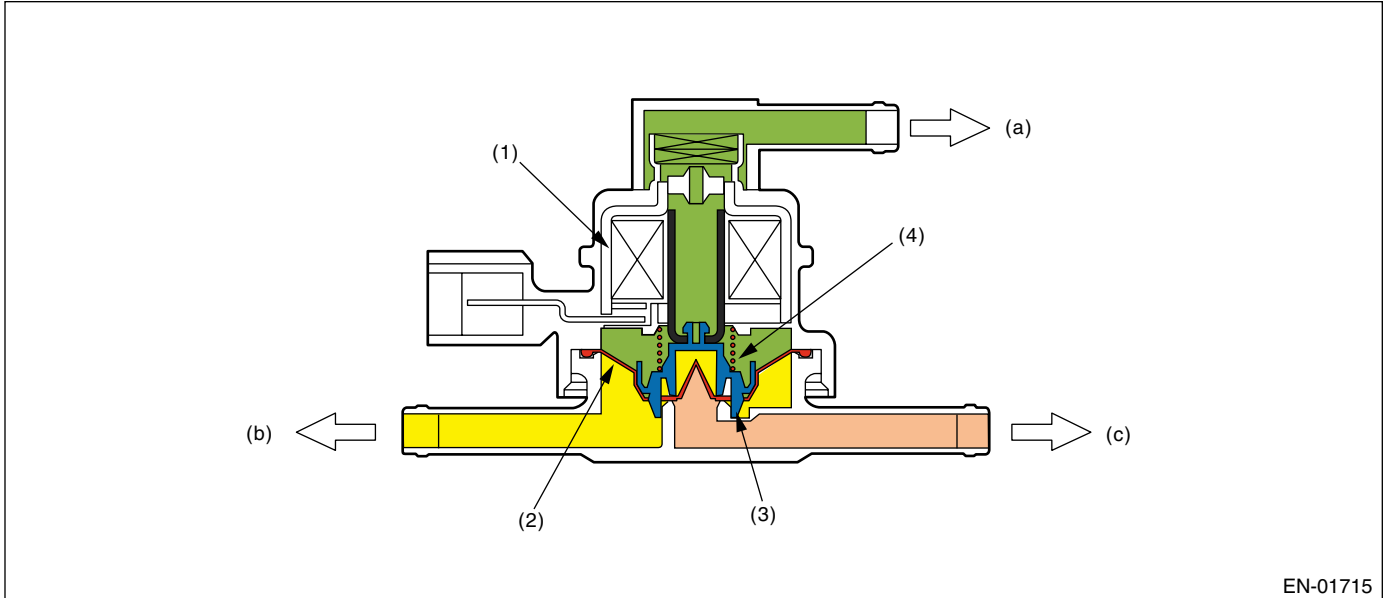

- (1) Solenoid
- (2) Diaphragm
- (3) Valve
- (4) Spring

- (a) Atmospheric pressure
- (b) Fuel tank
- (c) Canister

Diagnostic Trouble Code (DTC) Detecting Criteria

GENERAL DESCRIPTION

• Valve Operation and Air Flow

As in the X parts below, there are the area with atmospheric air pressure above the diaphragm and the area with tank pressure below the diaphragm. Also, as in the Y parts below, there are the area with tank pressure above the diaphragm and the area with canister pressure below the diaphragm. In the table below the air flow from each port in accordance with pressure difference is shown with the atmospheric air pressure port A, tank pressure port B and canister pressure port C.

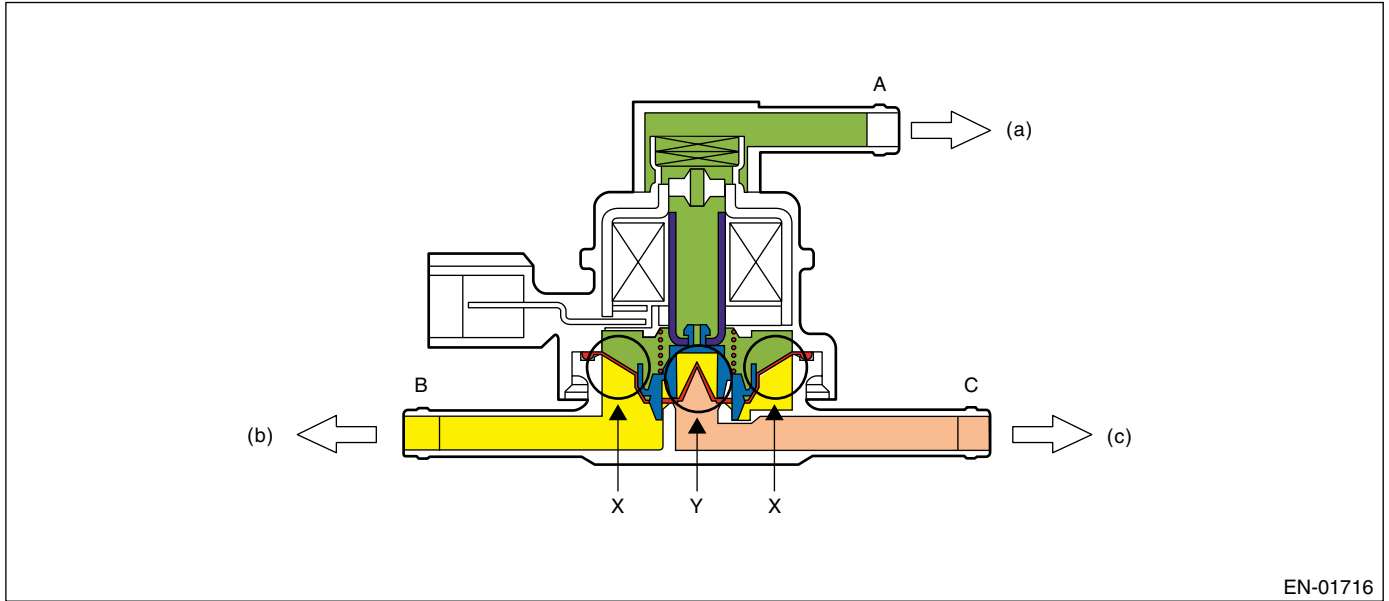

- (a) Atmospheric pressure
- (b) Fuel tank
- (c) Canister

Pressure Status	Flow
$A < B$ (Solenoid OFF)	$B \rightarrow C$
$B < C$ (Solenoid OFF)	$C \rightarrow B$
Solenoid ON	$B \leftrightarrow C$

Diagnostic Trouble Code (DTC) Detecting Criteria

GENERAL DESCRIPTION

When $A < B$ (Solenoid OFF)

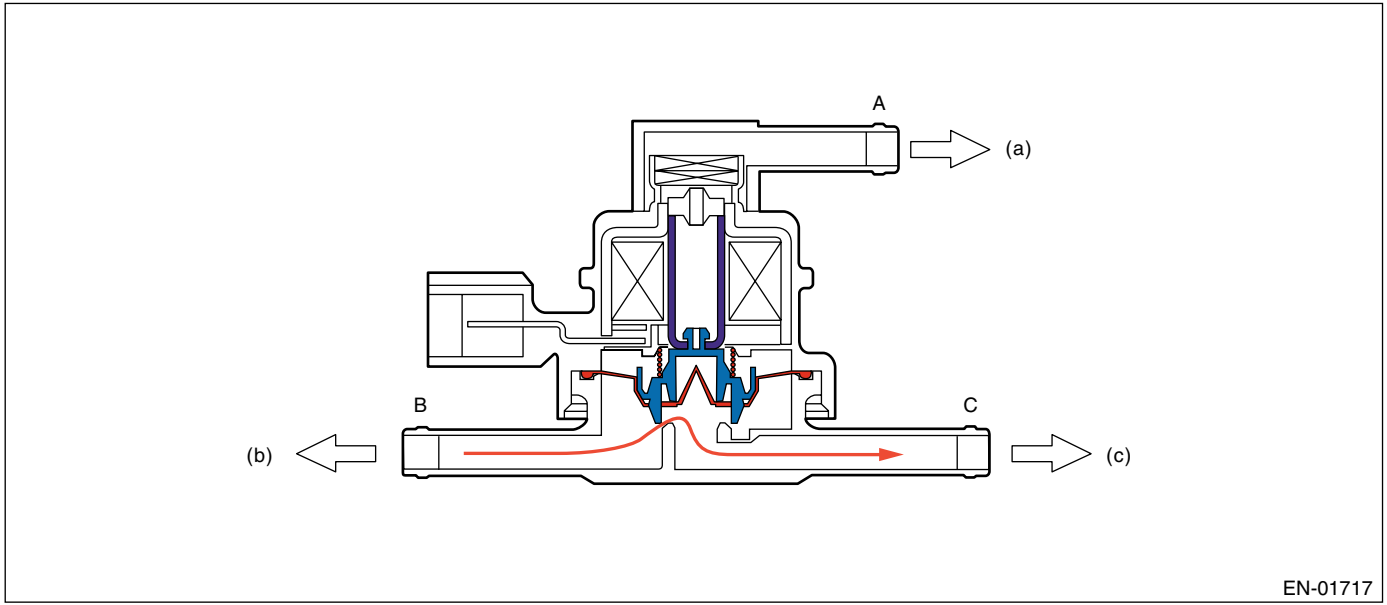

- (a) Atmospheric pressure
- (b) Fuel tank
- (c) Canister

When $B < C$ (Solenoid OFF)

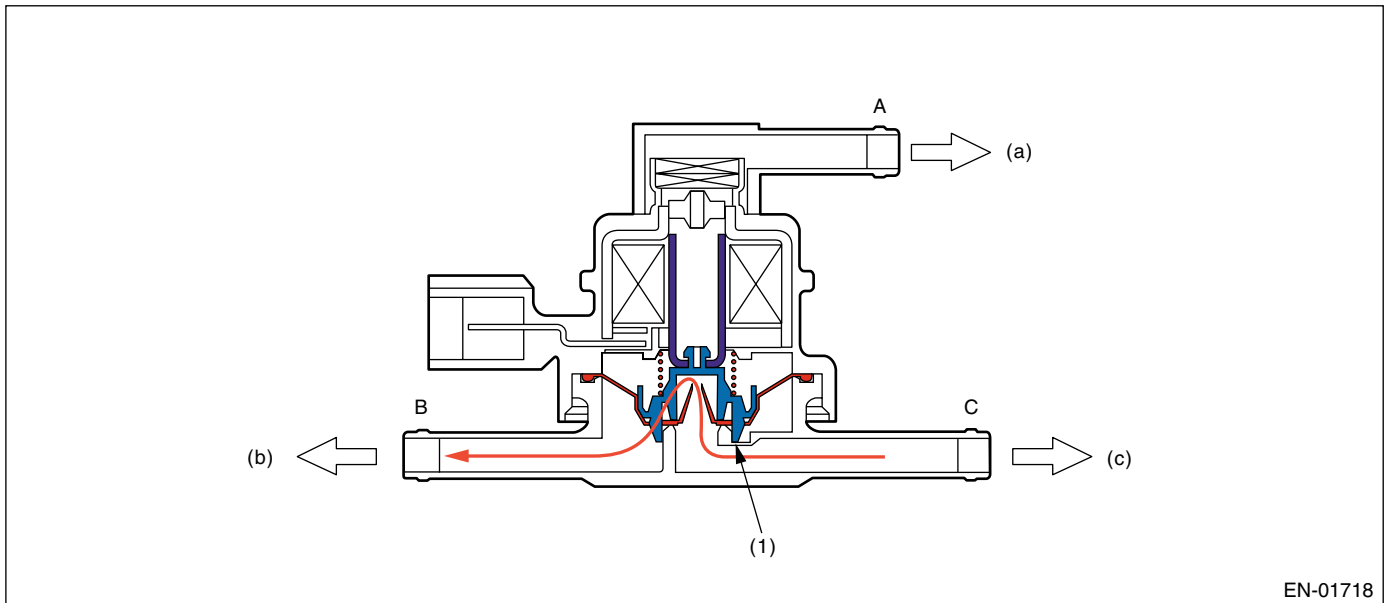

- (1) Valve
- (a) Atmospheric pressure
- (b) Fuel tank
- (c) Canister

Diagnostic Trouble Code (DTC) Detecting Criteria

GENERAL DESCRIPTION

When solenoid is ON

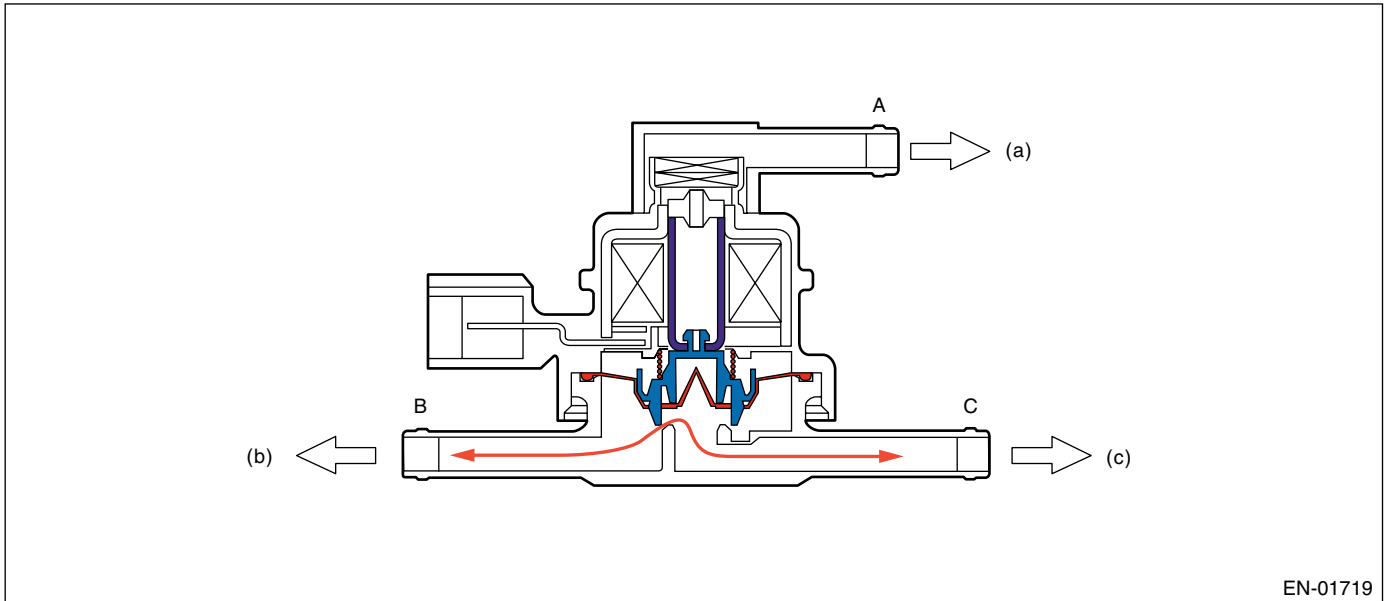

- (a) Atmospheric pressure
- (b) Fuel tank
- (c) Canister

• Drain valve

Drain valve controls the ambient air to be introduced to the canister.

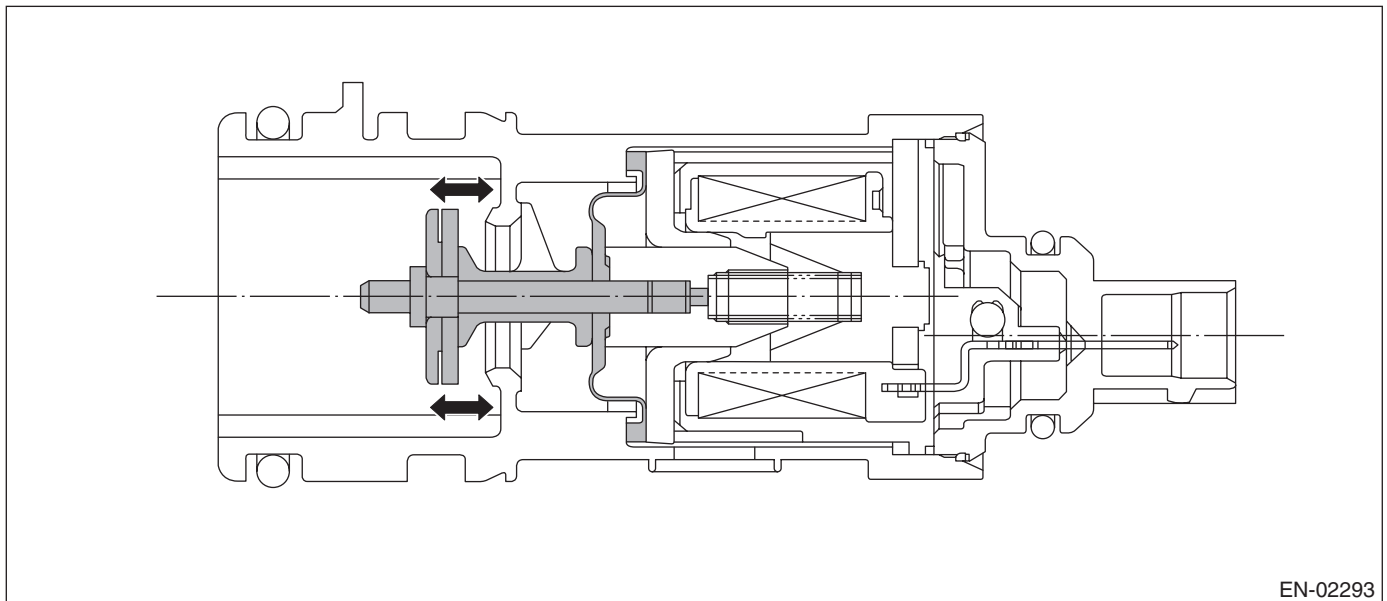

Diagnostic Trouble Code (DTC) Detecting Criteria

GENERAL DESCRIPTION

3. ENABLE CONDITION

0.04-inch Diagnosis

Secondary Parameters	Enable Conditions
Battery voltage	≥ 10.9 V
Barometric pressure	≥ 75.0 kPa (563 mmHg, 22.2 inHg)
Cumulative time of canister purge	120 seconds or more
After engine starting	856 seconds or more
Learning value of evaporation gas density	≤ 0.04
Engine speed	1,050 \longleftrightarrow 6,500 rpm
Fuel tank pressure	≥ -1.4 kPa (-10.7 mmHg, -0.42 inHg)
Intake manifold vacuum (relative pressure)	< -13.3 kPa (-100 mmHg, -3.94 inHg)
Vehicle speed	≥ 32 km/h (19.9 MPH)
Fuel level	9 \longleftrightarrow 51 \varnothing (2.38 \longleftrightarrow 13.47 US gal, 1.98 \longleftrightarrow 11.22 Imp gal)
Closed air/fuel ratio control	In operation
Fuel temperature	-10 \longleftrightarrow 45°C (14 \longleftrightarrow 113°F)
Intake air temperature	≥ -10 °C (14°F)
Pressure change per second	< 0.23 kPa (1.7 mmHg, 0.07 inHg)
Min. pressure change per second – Max. pressure change per second	< 0.23 kPa (1.7 mmHg, 0.07 inHg)
Fuel level change	< 2.5 \varnothing /128 milliseconds (0.66 US gal/128 milliseconds, 0.55 Imp gal/128 milliseconds)
Air fuel ratio	0.76 — 1.25

Diagnostic Trouble Code (DTC) Detecting Criteria

GENERAL DESCRIPTION

0.02-inch Diagnosis

Secondary Parameters	Enable Conditions
(At starting a diagnosis)	
Evaporation diagnosis	Not completed
Battery voltage	≥ 10.9 V
Atmospheric pressure	≥ 75.0 kPa (563 mmHg, 22.2 inHg)
Since last incomplete diagnosis event of 0.02-inch leakage	
Cancelled at mode A	> 120 seconds
Cancelled at other than mode A	> 600 seconds
Cumulative time of canister purge	120 seconds or more
After engine starting	770 second or more
Fuel temperature	-10 — 70°C (14 — 158°F)
Fuel level	9 — 51 ℓ (2.38 — 13.47 US gal, 1.98 — 11.22 Imp gal)
Intake manifold vacuum (relative pressure)	< -13.3 kPa (-100 mmHg, -3.93 inHg)
Fuel tank pressure	-0.67 — 1.43 kPa (-5 — 10.7 mmHg, -0.20 — 0.42 inHg)
Vehicle speed	≥ 68 km/h (42 MPH)
Closed air/fuel ratio control	In operation
Engine speed	550 ↔ 6,000 rpm
(During diagnosis)	
Fuel level change	≤ Value of Map
Pressure change per second	< 0.06 kPa (0.44 mmHg, 0.02 inHg)
Min. tank pressure change per second – Max. tank pressure change per second	< 0.07 kPa (0.51 mmHg, 0.02 inHg)
Tank pressure change per second	≤ 0.1 kPa (0.75 mmHg, 0.03 inHg)
Pressure change (Mode D)	-0.47 ↔ 0.32 kPa (-3.5 ↔ 2.4 mmHg, -0.14 ↔ 0.09 inHg)
Pressure change (Mode E)	-0.32 ↔ 0.32 kPa (-2.4 ↔ 2.4 mmHg, -0.09 ↔ 0.09 inHg)

Map

Fuel level (ℓ , US gal, Imp gal)	0	10, 2.64, 2.2	20, 5.28, 4.4	30, 7.93, 6.6	40, 10.57, 8.8	50, 13.21, 11	60, 15.85, 13.2
Variation (ℓ , US gal, Imp gal)	4.2, 1.11, 0.92	4.2, 1.11, 0.92	4.1, 1.08, 0.9	4.0, 1.06, 0.88	3.9, 1.03, 0.86	3.8, 1.0, 0.84	3.8, 1.0, 0.84

Diagnostic Trouble Code (DTC) Detecting Criteria

GENERAL DESCRIPTION

4. GENERAL DRIVING CYCLE

0.04-inch Diagnosis

- Perform the diagnosis only once in more than 856 seconds after the engine start at the constant driving speed of 32 km/h (19.9 MPH) or more.
- Pay attention to the fuel temperature and fuel level.

0.02-inch Diagnosis

- Perform diagnosis in more than 770 seconds after engine start at the constant speed of 68 km/h (42 MPH) or more, and judged OK or NG.
- If not judged OK or NG, repeat the diagnosis.
- Pay attention to the fuel level.

5. DIAGNOSTIC METHOD

- Diagnosing Function of Purge Control Solenoid Valve

DTC

P0457 Evaporative Emission Control System Leak Detected (Fuel Cap Loose/Off)

Purpose of Mode Z

When performing the leakage diagnosis of EVAP system, purge control solenoid valve have to operate normally. Therefore, mode Z is used to diagnose the purge control solenoid valve open fixation.

If purge control solenoid valve open fixation trouble is detected, the evaporation system leakage diagnosis is cancelled.

- Diagnosing function of purge control solenoid valve [P0457]

Purge control solenoid valve functional diagnosis is performed by monitoring the tank pressure in Mode Z.

Normality Judgment

Judge OK when the following criteria are satisfied in 3 seconds after Mode Z started, and change to Mode A.

Judgment Value

Malfunction Criteria	Threshold Value	DTC
(Tank pressure when Mode Z started) — (Tank pressure when Mode Z finished)	≤ 0.4 kPa (3 mmHg, 0.12 inHg)	P0457

- Normal

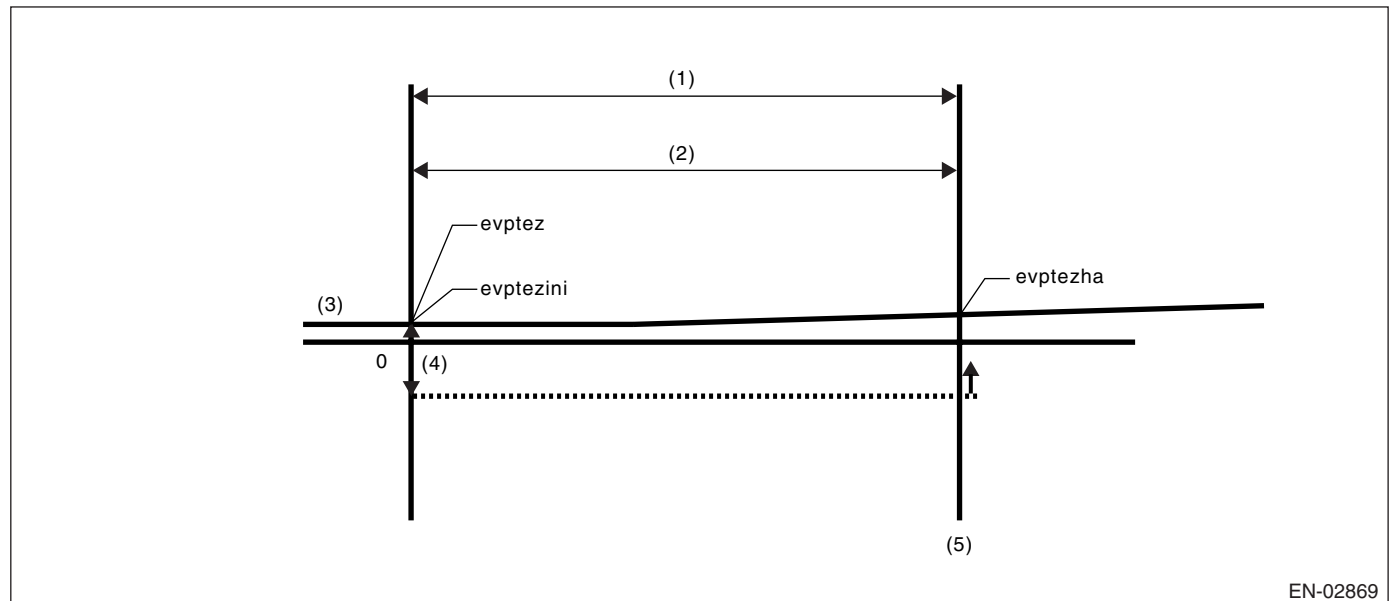

EN-02869

- | | | |
|---------------|-----------------------------------|------------------|
| (1) Mode Z | (3) Fuel tank pressure | (5) OK judgement |
| (2) 3 seconds | (4) 0.4 kPa (3.0 mmHg, 0.12 inHg) | |

Diagnostic Trouble Code (DTC) Detecting Criteria

GENERAL DESCRIPTION

Judge normal when the following conditions are completed at once.

- $evptez - evptezha \leq 0.4 \text{ kPa}$ (3.0 mmHg, 0.12 inHg)
- $evptezini - evptezha \leq 0.71 \text{ kPa}$ (5.3 mmHg, 0.21 inHg)

Abnormality Judgment

If OK judgment cannot be made, extend Mode Z 16 seconds more, and judge NG when all the criteria below are completed in 16 seconds.

Judgment Value

Malfunction Criteria	Threshold Value	DTC
(Tank pressure 1 second after Mode Z started) – (Tank pressure when Mode Z finished)	$> 0.6 \text{ kPa}$ (4.5 mmHg, 0.18 inHg)	P0457
Tank pressure when Mode Z started	$\leq 1.43 \text{ kPa}$ (10.7 mmHg, 0.42 inHg)	
Time for no fuel rolling of 2 \varnothing or more	$\geq 40 \text{ seconds}$	

Time Needed for Diagnosis: 16 seconds

Malfunction Indicator Light Illumination: Illuminates when malfunction occurs in 2 continuous driving cycles.

Finish the Evap. diagnosis when making NG judgment for purge control solenoid valve open fixation.

Cancel the Evap. diagnosis when the OK/NG judgment for purge control solenoid valve open fixation cannot be made in Mode Z.

Diagnostic Trouble Code (DTC) Detecting Criteria

GENERAL DESCRIPTION

• Leak Diagnosis

DTC

P0442 Evaporative Emission Control System Leak Detected (small leak)

P0457 Evaporative Emission Control System Leak Detected (fuel cap loose/off)

Diagnostic method

- The diagnostic method consists of creating a sealed vacuum in the fuel tank and then determining the presence of leakage from the speed at which the tank internal pressure returns to atmospheric pressure.
- This diagnostic method consists of 5 steps.

Mode A: (Estimation of evaporation gas yield)

The amount of change of tank pressure (P1) in Mode A is calculated. After calculating P1, change to Mode B.

Mode B: (Seal negative pressure)

Introduce the negative pressure in the intake manifold to the tank.

Approx. 0 → -1.4 kPa (0 → -10.5 mmHg, 0 → -0.41 inHg)

When the pressure above (desired negative pressure) is reached, Mode C is entered.

In this case, if the tank pressure does not become the desired negative pressure, judge that there is a large leakage in the system and judge as large leak (10 or 25 seconds).

Abnormality Judgment

Judge NG (large leak) when the criteria below are completed in the specified time.

Judgment Value

Malfunction Criteria	Threshold Value	DTC
Time before reaching desired negative pressure	≥ 25 seconds	P0457
Or time for Mode B	≥ 10 seconds	
(Min. value of tank pressure during Mode B) – (Tank pressure when Mode B started)	< -0.5 kPa (-4 mmHg, -0.16 inHg)	

Mode C: (Check increasing pressure)

Stop the introduction of negative pressure. (Wait until the tank pressure returns to the start level of P2 calculation.)

Change to Mode D when the tank pressure returns to the start level of P2 calculation.

Judge immediate OK and change to Mode E when it does not return in spite of spending the specified time.

Tank pressure when P2 calculation started	Time for immediate OK judgment
-1.3 kPa (-9.75 mmHg, -0.38 inHg)	15 seconds

Mode D: (Measurement of negative pressure changes)

Monitor the pressure variation in the tank in Mode Z. In this case, the tank pressure increases, that is, the pressure becomes as high as the atmospheric air pressure, because evaporator is generated. However, if any leakage exists, the pressure increases additionally in proportion to this leakage. The pressure variation of this tank is P2.

After calculating P2, perform following small leak diagnosis.

• After Mode D

Assigning P1 and P2, which are tank variations measured in Mode A and Mode B, to the formula below, judge the small leakage of the system. If the measured judgment value exceeds the threshold value, it is judged to be malfunction.

Diagnostic Trouble Code (DTC) Detecting Criteria

GENERAL DESCRIPTION

Abnormality Judgment

Judge NG when the criteria below are completed and judge OK and clear the NG when not completed.

Judgment Value

Malfunction Criteria	Threshold Value	DTC
P2 – 1.5 × P1 P2: Change of tank pressure within 16 seconds on Mode D P1: Change of tank pressure within 16 seconds on Mode A	> Value on Map 7. * Threshold value: Figure (Fuel level vs Tank temperature)	P0442

*1.5: Compensation value of the amount of evaporator occurrence. (Because evaporator increases more when becoming negative pressure.)

Map 7 Limit of malfunction criteria as Evap. diagnosis.

Fuel temperature & Fuel level	5°C (41°F)	15°C (59°F)	25°C (77°F)	35°C (95°F)	45°C (113°F)
0 L (0 US gal, 0 Imp gal)	0.49 kPa (3.68 mmHg, 0.14 inHg)	0.49 kPa (3.68 mmHg, 0.14 inHg)	0.53 kPa (3.95 mmHg, 0.16 inHg)	0.54 kPa (4.07 mmHg, 0.16 inHg)	0.56 kPa (4.17 mmHg, 0.16 inHg)
10 L (2.64 US gal, 2.2 Imp gal)	0.49 kPa (3.68 mmHg, 0.14 inHg)	0.49 kPa (3.68 mmHg, 0.14 inHg)	0.53 kPa (3.95 mmHg, 0.16 inHg)	0.54 kPa (4.07 mmHg, 0.16 inHg)	0.56 kPa (4.17 mmHg, 0.16 inHg)
20 L (5.28 US gal, 4.4 Imp gal)	0.50 kPa (3.77 mmHg, 0.15 inHg)	0.51 kPa (3.79 mmHg, 0.15 inHg)	0.53 kPa (4.01 mmHg, 0.16 inHg)	0.56 kPa (4.17 mmHg, 0.16 inHg)	0.57 kPa (4.27 mmHg, 0.17 inHg)
30 L (7.93 US gal, 6.6 Imp gal)	0.51 kPa (3.85 mmHg, 0.15 inHg)	0.52 kPa (3.9 mmHg, 0.15 inHg)	0.54 kPa (4.06 mmHg, 0.16 inHg)	0.57 kPa (4.27 mmHg, 0.17 inHg)	0.60 kPa (4.48 mmHg, 0.18 inHg)
40 L (10.57 US gal, 8.8 Imp gal)	0.65 kPa (4.88 mmHg, 0.19 inHg)	0.65 kPa (4.9 mmHg, 0.19 inHg)	0.66 kPa (4.98 mmHg, 0.20 inHg)	0.71 kPa (5.32 mmHg, 0.21 inHg)	0.76 kPa (5.73 mmHg, 0.23 inHg)
50 L (13.21 US gal, 11.0 Imp gal)	0.794 kPa (5.96 mmHg, 0.235 inHg)	0.794 kPa (5.96 mmHg, 0.235 inHg)	0.794 kPa (5.96 mmHg, 0.235 inHg)	0.85 kPa (6.38 mmHg, 0.25 inHg)	0.88 kPa (6.6 mmHg, 0.26 inHg)
60 L (15.85 US gal, 13.2 Imp gal)	0.794 kPa (5.96 mmHg, 0.235 inHg)	0.794 kPa (5.96 mmHg, 0.235 inHg)	0.794 kPa (5.96 mmHg, 0.235 inHg)	0.85 kPa (6.38 mmHg, 0.25 inHg)	0.88 kPa (6.6 mmHg, 0.26 inHg)

Time Needed for Diagnosis: 30 — 100 seconds

Malfunction Indicator Light Illumination: Illuminates when malfunction occurs in 2 continuous drive cycles.

Leak diagnosis

DTC

P0456 Evaporative Emission Control System (Very Small Leak)

• Diagnostic method

- The diagnostic method consists of creating a sealed vacuum in the fuel tank and then determining the presence of leakage from the speed at which the tank internal pressure returns to atmospheric pressure.
- This diagnostic method consists of 5 steps.

Mode A: (0 point correction)

Wait until the tank pressure returns to 0 point (around 0 mmHg) when the tank pressure is high. Change to Mode B when the tank pressure becomes 0. Cancel the diagnosis when the tank pressure does not return to 0 point in spite of spending the specified time.

Mode B: (Introduce negative pressure)

Introduce the intake manifold negative pressure to fuel tank.

About 0 → -2.0 kPa (0 mmHg → -15 mmHg, 0 → -0.59 inHg)

Change to Mode C when the tank pressure becomes the pressure (desired negative pressure) above. Cancel the diagnosis when the tank pressure does not become the value above.

Diagnostic Trouble Code (DTC) Detecting Criteria

GENERAL DESCRIPTION

Mode C: (Hold negative pressure)

Stop introducing the negative pressure and wait the tank pressure returns to the start level of P2 calculation. Change to Mode D when the tank pressure returns to the start level of P2 calculation or when spending the specified time.

Mode D: (Calculation of negative pressure variation)

Monitor the tank pressure on Mode D, and calculate the tank pressure variation (P2) and time until it returns to the end level of P2 (evpdset). When it returns, change to Mode E. Make advanced OK judgment or cancel depending on the P2 level, when it doesn't return in spite of spending the specified time.

Normality Judgment

Judge OK when the criteria below are completed.

Judgment Value

Malfunction Criteria	Threshold Value
Advanced OK judgment #1	
Mode D time	≥ 30 s
Tank pressure	≤ -1.8 kPa (-13.4 mmHg, -0.53 inHg)
Advanced OK judgment #2	
Mode D time	≥ 200 s
P2	≤ 0.9 — 1.3 kPa (7 — 9.6 mmHg, 0.28 — 0.38 inHg)

Mode E: (Calculation of evaporation gas yield)

Calculate the tank pressure variation P1 in time evpdset, judge NG/OK from P1 value. (Gray judgment possible)

Abnormal judgment

Judge NG when the criteria below are completed.

Judgment Value

Malfunction Criteria	Threshold Value
P1	< Map 7 value * Threshold value: map (fuel level vs evpdset)

Map 7 Limit of malfunction criteria as Evap. diagnosis

Time (evpdset) & Fuel level	0 second	30 seconds	80 seconds	100 seconds	150 seconds	200 seconds
0 L (0 US gal, 0 Imp gal)	0 kPa (0 mmHg, 0 inHg)	0.21 kPa (1.6 mmHg, 0.06 inHg)	0.29 kPa (2.2 mmHg, 0.09 inHg)	0.29 kPa (2.2 mmHg, 0.09 inHg)	0.29 kPa (2.2 mmHg, 0.09 inHg)	0.29 kPa (2.2 mmHg, 0.09 inHg)
10 L (2.64 US gal, 2.2 Imp gal)	0 kPa (0 mmHg, 0 inHg)	0.21 kPa (1.6 mmHg, 0.06 inHg)	0.29 kPa (2.2 mmHg, 0.09 inHg)	0.29 kPa (2.2 mmHg, 0.09 inHg)	0.29 kPa (2.2 mmHg, 0.09 inHg)	0.29 kPa (2.2 mmHg, 0.09 inHg)
30 L (7.93 US gal, 6.6 Imp gal)	0 kPa (0 mmHg, 0 inHg)	0.21 kPa (1.6 mmHg, 0.06 inHg)	0.29 kPa (2.2 mmHg, 0.09 inHg)	0.29 kPa (2.2 mmHg, 0.09 inHg)	0.29 kPa (2.2 mmHg, 0.09 inHg)	0 kPa (0 mmHg, 0 inHg)
50 L (13.21 US gal, 11.0 Imp gal)	0 kPa (0 mmHg, 0 inHg)	0.24 kPa (1.8 mmHg, 0.07 inHg)	0.29 kPa (2.2 mmHg, 0.09 inHg)	0.29 kPa (2.2 mmHg, 0.09 inHg)	0 kPa (0 mmHg, 0 inHg)	0 kPa (0 mmHg, 0 inHg)
60 L (15.85 US gal, 13.2 Imp gal)	0 kPa (0 mmHg, 0 inHg)	0.24 kPa (1.8 mmHg, 0.07 inHg)	0.29 kPa (2.2 mmHg, 0.09 inHg)	0.29 kPa (2.2 mmHg, 0.09 inHg)	0 kPa (0 mmHg, 0 inHg)	0 kPa (0 mmHg, 0 inHg)
70 L (18.49 US gal, 15.4 Imp gal)	0 kPa (0 mmHg, 0 inHg)	0.24 kPa (1.8 mmHg, 0.07 inHg)	0.29 kPa (2.2 mmHg, 0.09 inHg)	0.29 kPa (2.2 mmHg, 0.09 inHg)	0 kPa (0 mmHg, 0 inHg)	0 kPa (0 mmHg, 0 inHg)
80 L (21.14 US gal, 17.6 Imp gal)	0 kPa (0 mmHg, 0 inHg)	0.24 kPa (1.8 mmHg, 0.07 inHg)	0.29 kPa (2.2 mmHg, 0.09 inHg)	0.29 kPa (2.2 mmHg, 0.09 inHg)	0 kPa (0 mmHg, 0 inHg)	0 kPa (0 mmHg, 0 inHg)

Diagnostic Trouble Code (DTC) Detecting Criteria

GENERAL DESCRIPTION

Normality Judgment

Judge OK when all the malfunction criteria below are completed.

Judgment Value

Malfunction Criteria	Threshold Value
P1	> Value of Map 8 * Threshold value: Map (Fuel level vs evp-dset)

Map 8

Time (evpdset) & Fuel level	0 second	30 seconds	80 seconds	100 seconds	150 seconds	200 seconds
0 L (0 US gal, 0 Imp gal)	0.16 kPa (1.2 mmHg, 0.05 inHg)	0.37 kPa (2.8 mmHg, 0.11 inHg)	0.45 kPa (3.4 mmHg, 0.13 inHg)	0.45 kPa (3.4 mmHg, 0.13 inHg)	0.45 kPa (3.4 mmHg, 0.13 inHg)	0.45 kPa (3.4 mmHg, 0.13 inHg)
10 L (2.64 US gal, 2.2 Imp gal)	0.16 kPa (1.2 mmHg, 0.05 inHg)	0.37 kPa (2.8 mmHg, 0.11 inHg)	0.45 kPa (3.4 mmHg, 0.13 inHg)	0.45 kPa (3.4 mmHg, 0.13 inHg)	0.45 kPa (3.4 mmHg, 0.13 inHg)	0.45 kPa (3.4 mmHg, 0.13 inHg)
30 L (7.93 US gal, 6.6 Imp gal)	0.16 kPa (1.2 mmHg, 0.05 inHg)	0.37 kPa (2.8 mmHg, 0.11 inHg)	0.45 kPa (3.4 mmHg, 0.13 inHg)	0.45 kPa (3.4 mmHg, 0.13 inHg)	0.45 kPa (3.4 mmHg, 0.13 inHg)	0.45 kPa (3.4 mmHg, 0.13 inHg)
50 L (13.21 US gal, 11.0 Imp gal)	0.16 kPa (1.2 mmHg, 0.05 inHg)	0.40 kPa (3.0 mmHg, 0.12 inHg)	0.45 kPa (3.4 mmHg, 0.13 inHg)	0.45 kPa (3.4 mmHg, 0.13 inHg)	0.45 kPa (3.4 mmHg, 0.13 inHg)	0.45 kPa (3.4 mmHg, 0.13 inHg)
60 L (15.85 US gal, 13.2 Imp gal)	0.16 kPa (1.2 mmHg, 0.05 inHg)	0.40 kPa (3.0 mmHg, 0.12 inHg)	0.45 kPa (3.4 mmHg, 0.13 inHg)	0.45 kPa (3.4 mmHg, 0.13 inHg)	0.45 kPa (3.4 mmHg, 0.13 inHg)	0.45 kPa (3.4 mmHg, 0.13 inHg)
70 L (18.49 US gal, 15.4 Imp gal)	0.16 kPa (1.2 mmHg, 0.05 inHg)	0.40 kPa (3.0 mmHg, 0.12 inHg)	0.45 kPa (3.4 mmHg, 0.13 inHg)	0.45 kPa (3.4 mmHg, 0.13 inHg)	0.45 kPa (3.4 mmHg, 0.13 inHg)	0.45 kPa (3.4 mmHg, 0.13 inHg)
80 L (21.14 US gal, 17.6 Imp gal)	0.16 kPa (1.2 mmHg, 0.05 inHg)	0.40 kPa (3.0 mmHg, 0.12 inHg)	0.45 kPa (3.4 mmHg, 0.13 inHg)	0.45 kPa (3.4 mmHg, 0.13 inHg)	0.45 kPa (3.4 mmHg, 0.13 inHg)	0.45 kPa (3.4 mmHg, 0.13 inHg)

Time Needed for Diagnosis: 65 — 516 seconds

6. DTC CLEAR CONDITION

- When the OK idling cycle was completed 40 times in a row
- When "Clear Memory" was performed

7. MALFUNCTION INDICATOR LIGHT CLEAR CONDITION

- When the OK driving cycle was completed 3 times in a row
- When "Clear Memory" was performed

8. FAIL SAFE

None

9. ECM OPERATION AT DTC SETTING

- Memorize the freeze frame data. (For test mode \$02)
- Memorize the diagnostic value and trouble standard value. (For test mode \$06)

BL:DTC P0447 EVAPORATIVE EMISSION CONTROL SYSTEM VENT CONTROL CIRCUIT OPEN

1. OUTLINE OF DIAGNOSIS

Detect the open or short circuit of drain valve.

Judge NG when the ECM output level is different from the actual terminal level.

2. COMPONENT DESCRIPTION

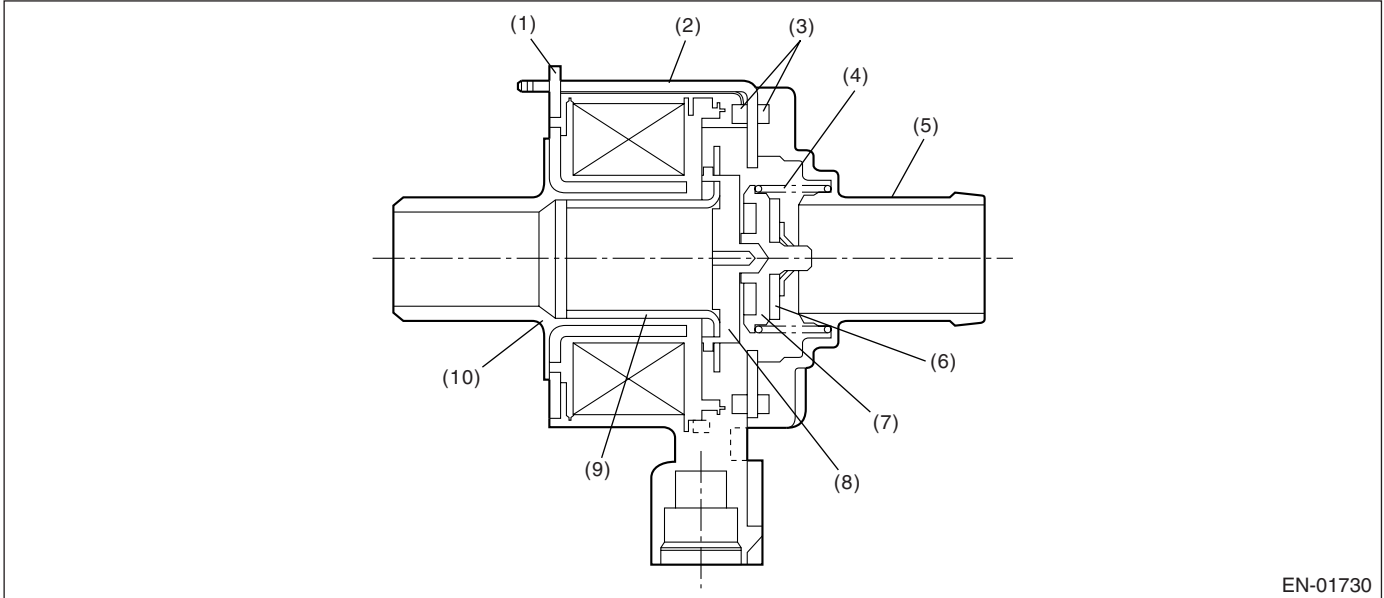

- | | | |
|--------------------|----------------|------------------|
| (1) Magnetic plate | (5) Valve seat | (9) Movable core |
| (2) Yoke | (6) Valve | (10) Bobbin |
| (3) Packing | (7) Plate | |
| (4) Spring | (8) Retainer | |

3. ENABLE CONDITION

Secondary Parameters	Enable Conditions
None	

4. GENERAL DRIVING CYCLE

Always perform the diagnosis continuously.

5. DIAGNOSTIC METHOD

• Abnormality Judgment

Judge NG when the continuous time of completing the malfunction criteria below becomes more than 2.5 seconds.

Judgment Value

Malfunction Criteria	Threshold Value
Ignition switch	ON
Battery voltage	$\geq 10.9 \text{ V}$
After engine starting	1 second or more
Terminal output voltage when ECM sends OFF signal	Low

Time Needed for Diagnosis: 2.5 seconds

Malfunction Indicator Light Illumination: Illuminates as soon as the malfunction occurs.

Diagnostic Trouble Code (DTC) Detecting Criteria

GENERAL DESCRIPTION

• Normality Judgment

Judge OK and clear the NG when the malfunction criteria below are completed.

Judgment Value

Malfunction Criteria	Threshold Value
Ignition switch	ON
Battery voltage	≥ 10.9 V
After engine starting	1 second or more
Terminal output voltage when ECM sends OFF signal	High

6. DTC CLEAR CONDITION

- When the OK idling cycle was completed 40 times in a row
- When "Clear Memory" was performed

7. MALFUNCTION INDICATOR LIGHT CLEAR CONDITION

- When the OK driving cycle was completed 3 times in a row
- When "Clear Memory" was performed

8. FAIL SAFE

Pressure control solenoid valve control: Open the pressure control solenoid valve solenoid.

9. ECM OPERATION AT DTC SETTING

Memorize the freeze frame data. (For test mode \$02)

BM:DTC P0448 EVAPORATIVE EMISSION CONTROL SYSTEM VENT CONTROL CIRCUIT SHORTED

1. OUTLINE OF DIAGNOSIS

Detect the open or short circuit of drain valve.

Judge NG when the ECM output level is different from the actual terminal level.

2. COMPONENT DESCRIPTION

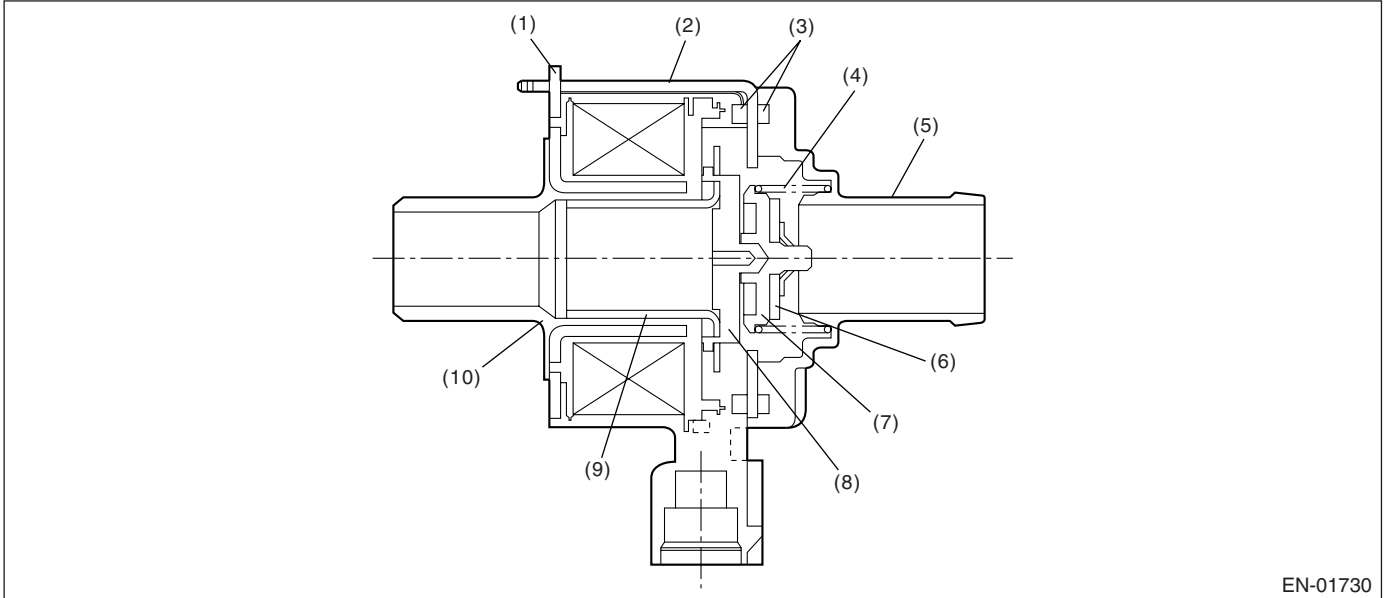

- | | | |
|--------------------|----------------|------------------|
| (1) Magnetic plate | (5) Valve seat | (9) Movable core |
| (2) Yoke | (6) Valve | (10) Bobbin |
| (3) Packing | (7) Plate | |
| (4) Spring | (8) Retainer | |

3. ENABLE CONDITION

Secondary Parameters	Enable Conditions
None	

4. GENERAL DRIVING CYCLE

Always perform the diagnosis continuously.

5. DIAGNOSTIC METHOD

• Abnormality Judgment

Judge NG when the continuous time of completing the malfunction criteria below becomes more than 2.5 seconds.

Judgment Value

Malfunction Criteria	Threshold Value
Ignition switch	ON
Battery voltage	$\geq 10.9 \text{ V}$
After engine starting	1 second or more
Terminal output voltage when ECM sends ON signal	High

Time Needed for Diagnosis: 2.5 seconds

Malfunction Indicator Light Illumination: Illuminates as soon as the malfunction occurs.

Diagnostic Trouble Code (DTC) Detecting Criteria

GENERAL DESCRIPTION

• Normality Judgment

Judge OK and clear the NG when the malfunction criteria below are completed.

Judgment Value

Malfunction Criteria	Threshold Value
Ignition switch	ON
Battery voltage	≥ 10.9 V
After engine starting	1 second or more
Terminal output voltage when ECM sends ON signal	Low

6. DTC CLEAR CONDITION

- When the OK idling cycle was completed 40 times in a row
- When "Clear Memory" was performed

7. MALFUNCTION INDICATOR LIGHT CLEAR CONDITION

- When the OK driving cycle was completed 3 times in a row
- When "Clear Memory" was performed

8. FAIL SAFE

PCV control: Open the PCV solenoid.

9. ECM OPERATION AT DTC SETTING

Memorize the freeze frame data. (For test mode \$02)

BN:DTC P0451 EVAPORATIVE EMISSION CONTROL SYSTEM PRESSURE SENSOR RANGE/PERFORMANCE

1. OUTLINE OF DIAGNOSIS

Detect the tank pressure sensor output property abnormality.

Judge NG when there is no pressure variation, which should exist in the tank, considering the engine status.

2. COMPONENT DESCRIPTION

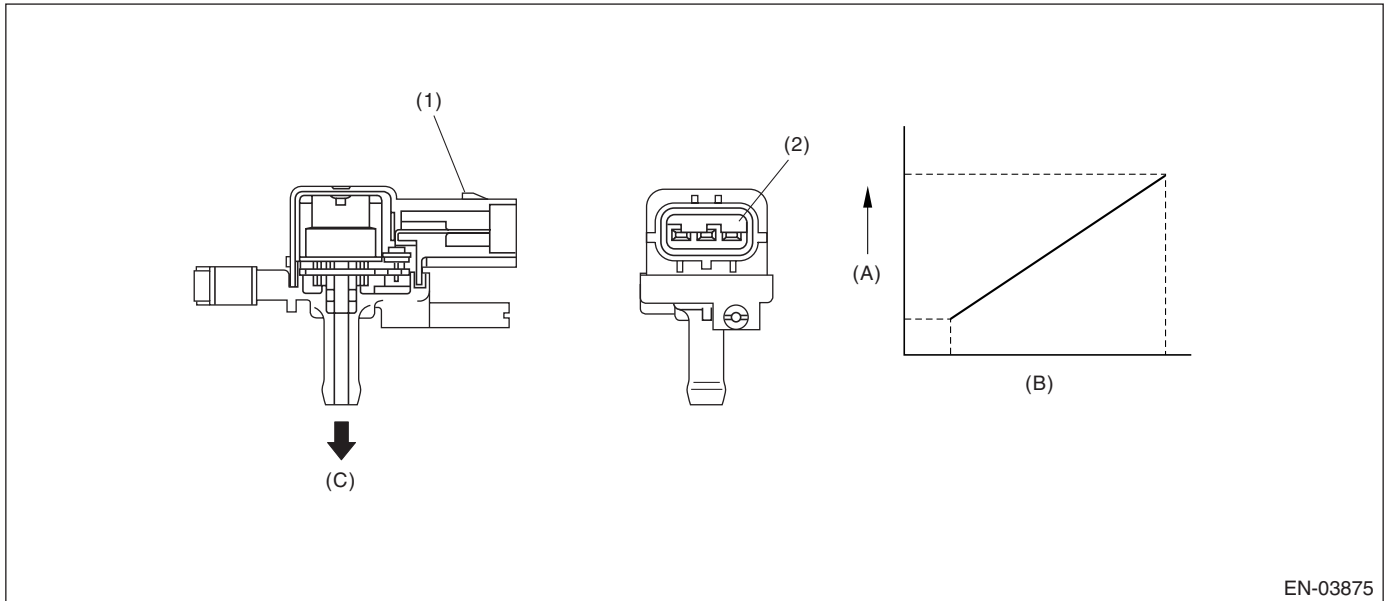

EN-03875

- (1) Connector
- (2) Terminal

- (A) Output voltage
- (B) Input voltage
- (C) To fuel tank

3. ENABLE CONDITION

Secondary Parameters	Enable Conditions
After starting the engine	60 second or more
Fuel level	$\geq 9 \ell$ (2.38 US gal, 1.98 Imp gal)
Fuel temperature	$< 35^{\circ}\text{C}$ (95°F)
Battery voltage	$\geq 10.9 \text{ V}$
Atmospheric pressure	$> 75.0 \text{ kPa}$ (563 mmHg, 22.2 inHg)
Purge control solenoid valve ON/OFF	Experienced

4. GENERAL DRIVING CYCLE

- Perform the diagnosis continuously in 60 seconds or more after starting the engine.
- Be sure to check the fuel level and fuel temperature.

Diagnostic Trouble Code (DTC) Detecting Criteria

GENERAL DESCRIPTION

5. DIAGNOSTIC METHOD

• Abnormality Judgment

Judge NG when the malfunction criteria below is completed.

Judgment Value

Malfunction Criteria	Threshold Value
Number of times when the difference between the Max. fuel level and the Min. fuel level every 60 seconds is 2 ℓ (0.53 US gal, 0.44 Imp gal) or more (with enable condition completed)	≥ 16 times
Max. – Min. tank pressure (with enable condition completed)	< 0.05 kPa (0.375 mmHg, 0.02 inHg)
Max. – Min. fuel temperature (with enable condition completed)	≥ 7°C (13°F)

If the fuel level (Max. – Min.) in every 60 seconds is less than 2 ℓ, extend 60 seconds more and make judgment with the Max. and Min. fuel level in 120 seconds.

If the difference did not appear though the time extended, extend the time (180, 240, 300 seconds) and continue the judgment.

Diagnosis counter will count up when the difference of fuel level (Max. – Min.) is more than 5 ℓ.

Time Needed for Diagnosis: 1 minute × 16 times or more

Malfunction Indicator Light Illumination: Illuminates when malfunction occurs in two continuous drive cycles.

• Normality Judgment

Judge OK when the malfunction criteria below is completed.

Judgment Value

Malfunction Criteria	Threshold Value
Max. – Min. tank pressure	≥ 0.05 kPa (0.375 mmHg, 0.02 inHg)

6. DTC CLEAR CONDITION

- When the OK idling cycle was completed 40 times in a row
- When “Clear Memory” was performed

7. MALFUNCTION INDICATOR LIGHT CLEAR CONDITION

- When the OK driving cycle was completed 3 times in a row
- When “Clear Memory” was performed

8. FAIL SAFE

Purge control solenoid valve control: Purge fixation mode is prohibited.

9. ECM OPERATION AT DTC SETTING

Memorize the freeze frame data. (For test mode \$02)

BO:DTC P0452 EVAPORATIVE EMISSION CONTROL SYSTEM PRESSURE SENSOR LOW INPUT

1. OUTLINE OF DIAGNOSIS

Detect the open or short circuit of the fuel tank pressure sensor.
Judge NG when out of the standard value.

2. COMPONENT DESCRIPTION

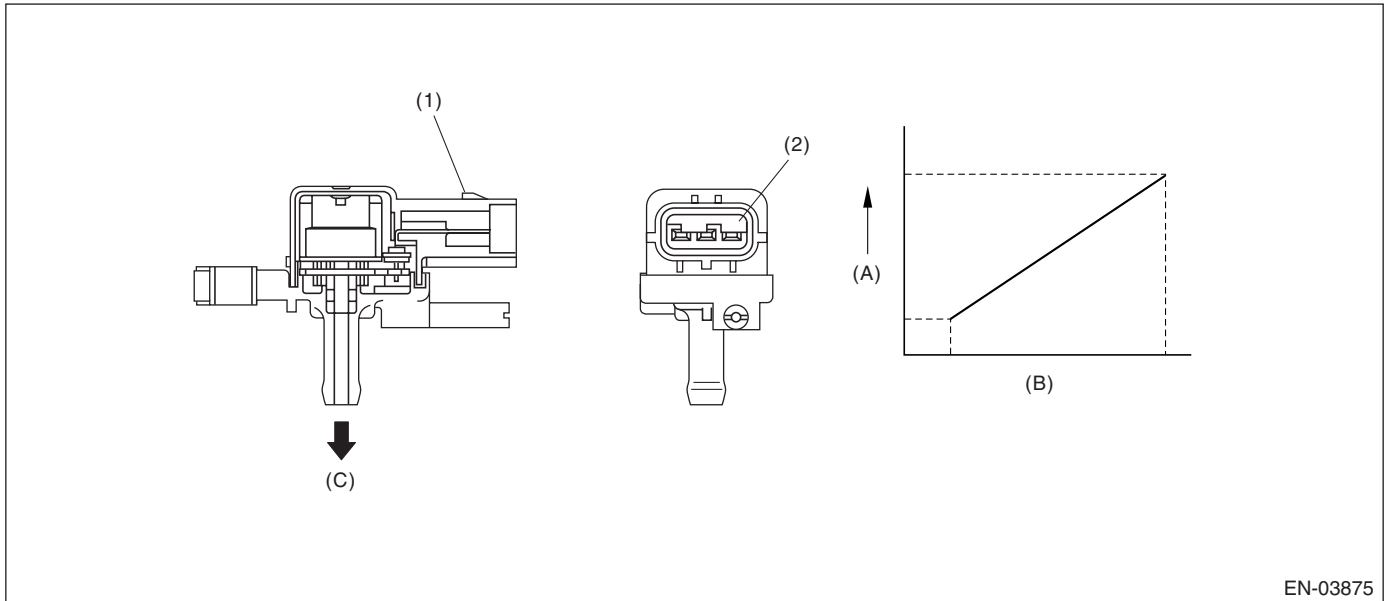

- (1) Connector
- (2) Terminal

- (A) Output voltage
- (B) Input voltage
- (C) To fuel tank

EN-03875

3. ENABLE CONDITION (USED WITH HIGH SIDE NORMAL/ABNORMAL JUDGMENT)

Secondary Parameters	Enable Conditions
Battery voltage	≥ 10.9

4. GENERAL DRIVING CYCLE

Always perform the diagnosis continuously.

5. DIAGNOSTIC METHOD

• Abnormality Judgment

Judge NG when the continuous time of completing the malfunction criteria below becomes more than 15 seconds.

Judgment Value

Malfunction Criteria	Threshold Value
Fuel tank pressure	$< -6.82 \text{ kPa } (-56.15 \text{ mmHg}, -2.01 \text{ inHg})$

Time Needed for Diagnosis: 15 seconds

Malfunction Indicator Light Illumination: Illuminates as soon as malfunction occurs.

Diagnostic Trouble Code (DTC) Detecting Criteria

GENERAL DESCRIPTION

• Normality Judgment

Judge OK when the malfunction criteria below is completed.

Judgment Value

Malfunction Criteria	Threshold Value
Fuel tank pressure	≥ -6.82 kPa (-56.15 mmHg, -2.01 inHg)
Feedback lambda coefficient	≥ 0.9

6. DTC CLEAR CONDITION

- When the OK idling cycle was completed 40 times in a row
- When "Clear Memory" was performed

7. MALFUNCTION INDICATOR LIGHT CLEAR CONDITION

- When the OK driving cycle was completed 3 times in a row
- When "Clear Memory" was performed

8. FAIL SAFE

Purge control solenoid valve control: Purge fixation mode is prohibited.

9. ECM OPERATION AT DTC SETTING

Memorize the freeze frame data. (For test mode \$02)

Diagnostic Trouble Code (DTC) Detecting Criteria

GENERAL DESCRIPTION

BP:DTC P0453 EVAPORATIVE EMISSION CONTROL SYSTEM PRESSURE SENSOR HIGH INPUT

1. OUTLINE OF DIAGNOSIS

Detect the breaking/shortage of the fuel tank pressure sensor.
Judge NG when out of the standard value.

2. COMPONENT DESCRIPTION

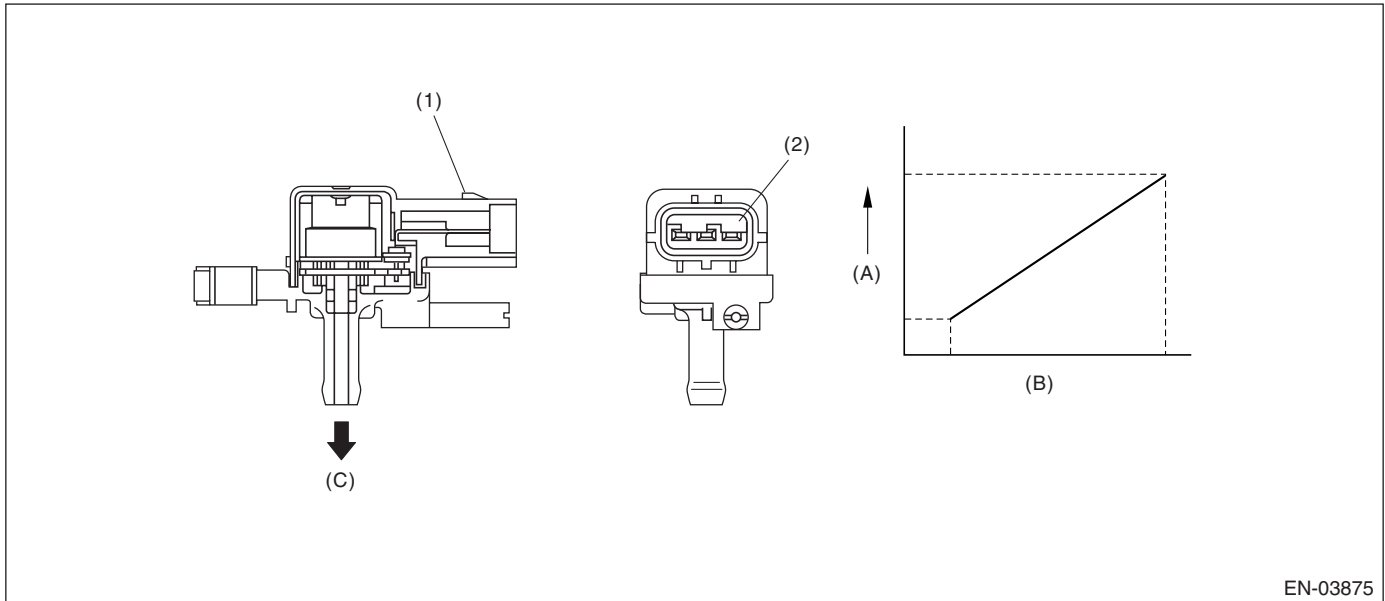

EN-03875

- (1) Connector
(2) Terminal

- (A) Output voltage
(B) Input voltage
(C) To fuel tank

3. ENABLE CONDITION

Secondary Parameters	Enable Conditions
Vehicle speed	≥ 2 km/h (1.24 MPH)
All conditions of EVAP canister purge	Complete
Evaporation gas density learning value	≤ 0.08
Main feedback compensation coefficient	≥ 0.9
Battery voltage	≥ 10.9 V

4. GENERAL DRIVING CYCLE

Perform the diagnosis continuously when purging.

5. DIAGNOSTIC METHOD

• Abnormality Judgment

Judge NG when the continuous time until completing the malfunction criteria below becomes more than 15 seconds.

Judgment Value

Malfunction Criteria	Threshold Value
Fuel tank pressure	≥ 7.98 kPa (59.85 mmHg, 2.36 inHg)
Fuel temperature	$< 35^{\circ}\text{C}$ (95 $^{\circ}\text{F}$)
Atmospheric pressure	≥ 75.0 kPa (563 mmHg, 22.2 inHg)

Diagnostic Trouble Code (DTC) Detecting Criteria

GENERAL DESCRIPTION

Time Needed for Diagnosis: 15 seconds

Malfunction Indicator Light Illumination: Illuminates as soon as malfunction occurs.

• **Normality Judgment**

Judge OK when the malfunction criteria below is completed.

Judgment Value

Malfunction Criteria	Threshold Value
Fuel tank pressure	< 7.98 kPa (59.85 mmHg, 2.36 inHg)

6. DTC CLEAR CONDITION

- When the OK idling cycle was completed 40 times in a row
- When "Clear Memory" was performed

7. MALFUNCTION INDICATOR LIGHT CLEAR CONDITION

- When the OK driving cycle was completed 3 times in a row
- When "Clear Memory" was performed

8. FAIL SAFE

Purge control solenoid valve control: Purge fixation mode is prohibited.

9. ECM OPERATION AT DTC SETTING

Memorize the freeze frame data. (For test mode \$02)

BQ:DTC P0456 EVAPORATIVE EMISSION CONTROL SYSTEM LEAK DETECTED (VERY SMALL LEAK)

1. OUTLINE OF DIAGNOSIS

For detecting conditions, refer to DTC P0442 EVAPORATIVE EMISSION CONTROL SYSTEM LEAK DETECTED (SMALL LEAK). <Ref. to GD(H4DOTC)-123, DTC P0442 EVAPORATIVE EMISSION CONTROL SYSTEM LEAK DETECTED (SMALL LEAK), Diagnostic Trouble Code (DTC) Detecting Criteria.>

BR:DTC P0457 EVAPORATIVE EMISSION CONTROL SYSTEM LEAK DETECTED (FUEL CAP LOOSE/OFF)

1. OUTLINE OF DIAGNOSIS

For detecting conditions, refer to DTC P0442 EVAPORATIVE EMISSION CONTROL SYSTEM LEAK DETECTED (SMALL LEAK). <Ref. to GD(H4DOTC)-123, DTC P0442 EVAPORATIVE EMISSION CONTROL SYSTEM LEAK DETECTED (SMALL LEAK), Diagnostic Trouble Code (DTC) Detecting Criteria.>

BS:DTC P0458 EVAPORATIVE EMISSION CONTROL SYSTEM PURGE CONTROL VALVE CIRCUIT LOW

1. OUTLINE OF DIAGNOSIS

Detect open or short circuit of purge control solenoid valve.
 Judge NG when ECM output level is different from actual terminal level.

2. COMPONENT DESCRIPTION

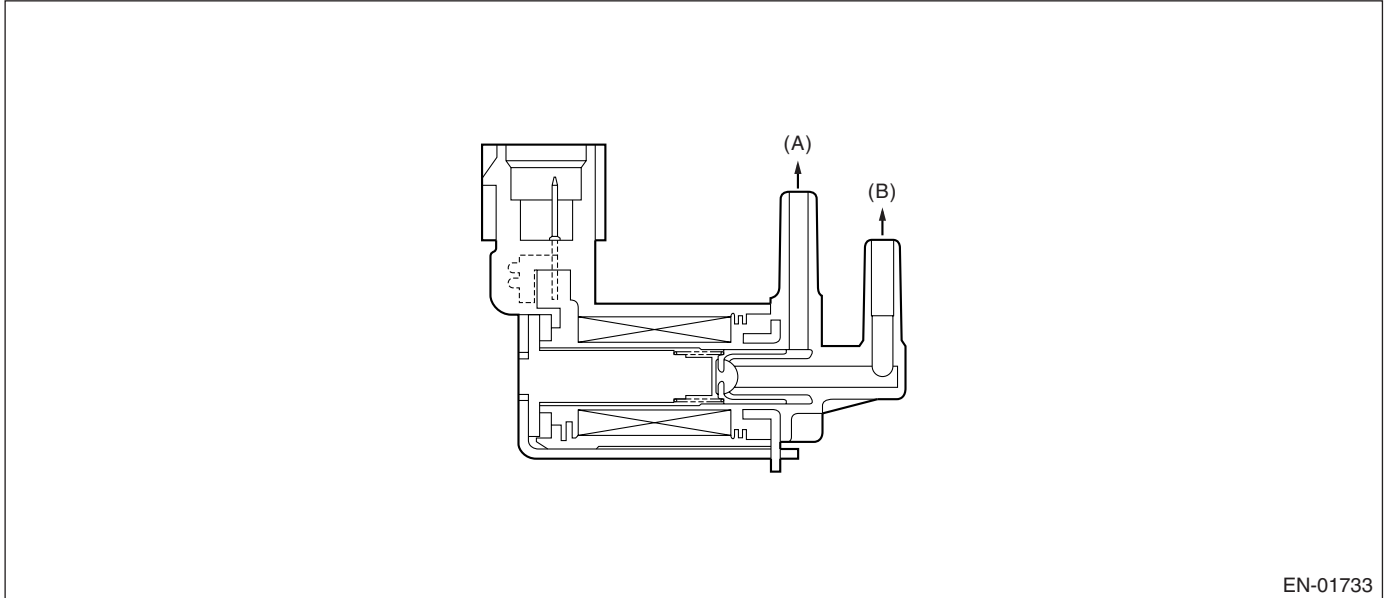

EN-01733

- (A) To intake manifold
- (B) To canister

3. ENABLE CONDITION

Secondary Parameters	Enable Conditions
Ignition switch	ON
Battery voltage	≥ 10.9 V
After engine starting	1 second or more

4. GENERAL DRIVING CYCLE

Always perform the diagnosis after starting the engine.

5. DIAGNOSTIC METHOD

• Abnormality Judgment

Judge NG when the continuous time of completing the malfunction criteria below becomes more than the time needed for diagnosis (2.5 seconds).

Judgment Value

Malfunction Criteria	Threshold Value
Duty ratio of 'ON'	< 75%
Terminal output voltage	Low

Time Needed for Diagnosis: 2.5 seconds

Malfunction Indicator Light Illumination: Illuminates as soon as malfunction occurs.

Diagnostic Trouble Code (DTC) Detecting Criteria

GENERAL DESCRIPTION

• Normality Judgment

Judge OK and clear NG when the malfunction criterion below is completed.

Judgment Value

Malfunction Criteria	Threshold Value
Terminal output voltage	High

6. DTC CLEAR CONDITION

- When the OK idling cycle was completed 40 times in a row
- When "Clear Memory" was performed

7. MALFUNCTION INDICATOR LIGHT CLEAR CONDITION

- When the OK driving cycle was completed 3 times in a row
- When "Clear Memory" was performed

8. FAIL SAFE

None

9. ECM OPERATION AT DTC SETTING

Memorize the freeze frame data. (For test mode \$02)

BT:DTC P0459 EVAPORATIVE EMISSION CONTROL SYSTEM PURGE CONTROL VALVE CIRCUIT HIGH

1. OUTLINE OF DIAGNOSIS

Detect open or short circuit of purge control solenoid valve.
 Judge NG when ECM output level is different from actual terminal level.

2. COMPONENT DESCRIPTION

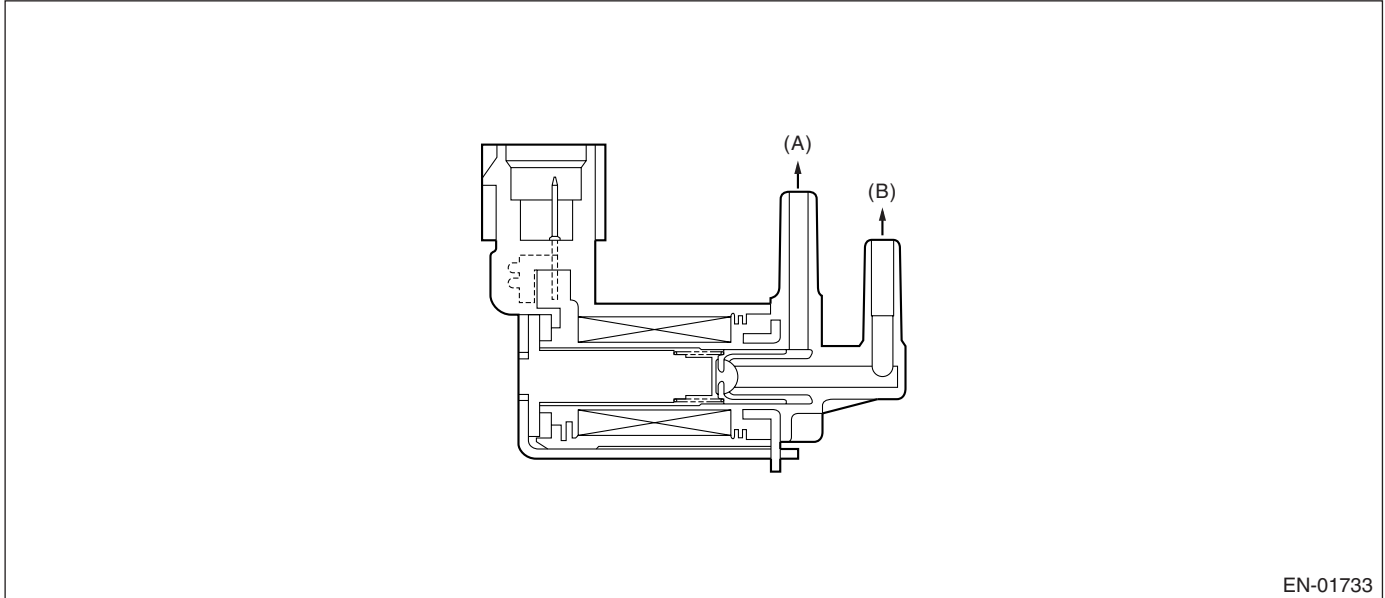

- (A) To intake manifold
- (B) To canister

3. ENABLE CONDITION

Secondary Parameters	Enable Conditions
Ignition switch	ON
Battery voltage	≥ 10.9 V
After engine starting	1 second or more

4. GENERAL DRIVING CYCLE

Always perform the diagnosis after starting the engine.

5. DIAGNOSTIC METHOD

• Abnormality Judgment

Judge NG when the continuous time of completing the malfunction criteria below becomes more than the time needed for diagnosis (2.5 seconds).

Judgment Value

Malfunction Criteria	Threshold Value
Duty ratio of 'ON'	≥ 25%
Terminal output voltage	High

Time Needed for Diagnosis: 2.5 seconds

Malfunction Indicator Light Illumination: Illuminates when malfunction occurs in 2 continuous driving cycles.

Diagnostic Trouble Code (DTC) Detecting Criteria

GENERAL DESCRIPTION

• Normality Judgment

Judge OK and clear NG when the malfunction criterion below is completed.

Judgment Value

Malfunction Criteria	Threshold Value
Terminal output voltage	Low

6. DTC CLEAR CONDITION

- When the OK idling cycle was completed 40 times in a row
- When "Clear Memory" was performed

7. MALFUNCTION INDICATOR LIGHT CLEAR CONDITION

- When the OK driving cycle was completed 3 times in a row
- When "Clear Memory" was performed

8. FAIL SAFE

None

9. ECM OPERATION AT DTC SETTING

Memorize the freeze frame data. (For test mode \$02)

BU:DTC P0461 FUEL LEVEL SENSOR CIRCUIT RANGE/PERFORMANCE

1. OUTLINE OF DIAGNOSIS

Detect the malfunction of fuel level sensor output property.

Judge NG when the fuel level does not vary whereas it seemed to vary be in a usual driving speed.

2. COMPONENT DESCRIPTION

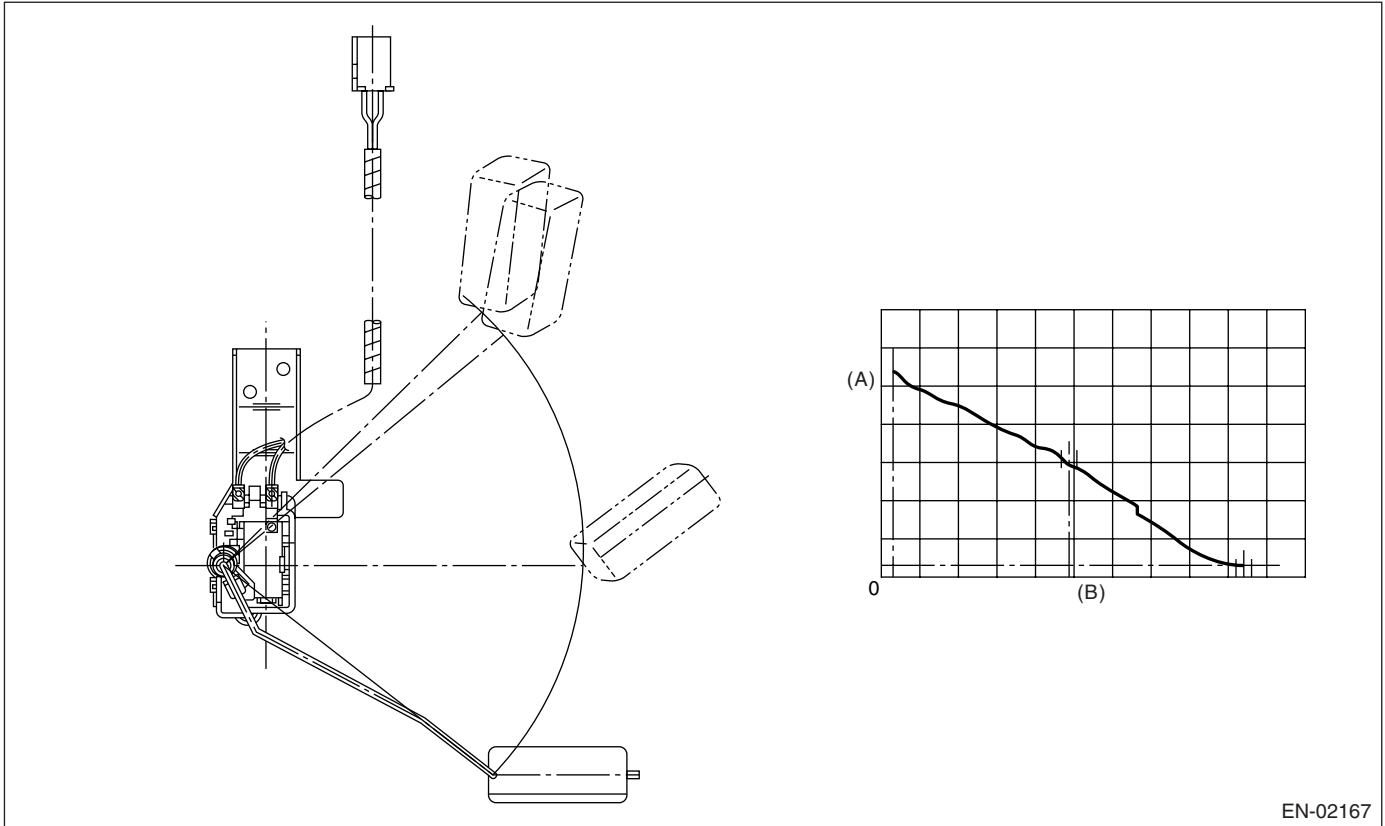

EN-02167

- (A) Fuel level (L)
- (B) Resistance (Ω)

3. ENABLE CONDITION

Secondary Parameters	Enable Conditions
None	

4. GENERAL DRIVING CYCLE

Always perform the diagnosis continuously.

5. DIAGNOSTIC METHOD

• Abnormality Judgment

Judge NG when the malfunction criteria below are completed.

Judgment Value

Malfunction Criteria	Threshold Value
Accumulated amount of intake air	> 331 kg (729.7 lb)
Max. – Min. fuel level output	< 2.6 ℓ (0.69 US gal, 0.57 Imp gal)
Battery voltage	\geq 10.9 V
After engine starting	10 seconds or more

Diagnostic Trouble Code (DTC) Detecting Criteria

GENERAL DESCRIPTION

Time Needed for Diagnosis: To be determined.

Malfunction Indicator Light Illumination: Illuminates when malfunction occurs in 2 continuous driving cycles.

• **Normality Judgment**

Judge OK and clear the NG when the malfunction criteria below are completed.

Judgment Value

Malfunction Criteria	Threshold Value
Accumulated amount of intake air	> 331 kg (729.7 lb)
Max. – Min. fuel level output	≥ 2.6 ℓ (0.69 US gal, 0.57 Imp gal)
Battery voltage	≥ 10.9 V
After engine starting	10 seconds or more

6. DTC CLEAR CONDITION

- When the OK idling cycle was completed 40 times in a row
- When “Clear Memory” was performed

7. MALFUNCTION INDICATOR LIGHT CLEAR CONDITION

- When the OK driving cycle was completed 3 times in a row
- When “Clear Memory” was performed

8. FAIL SAFE

None

9. ECM OPERATION AT DTC SETTING

Memorize the freeze frame data. (For test mode \$02)

BV:DTC P0462 FUEL LEVEL SENSOR CIRCUIT LOW INPUT

1. OUTLINE OF DIAGNOSIS

Detect the open or short circuit of fuel level sensor. Judge NG when out of the standard value.

2. COMPONENT DESCRIPTION

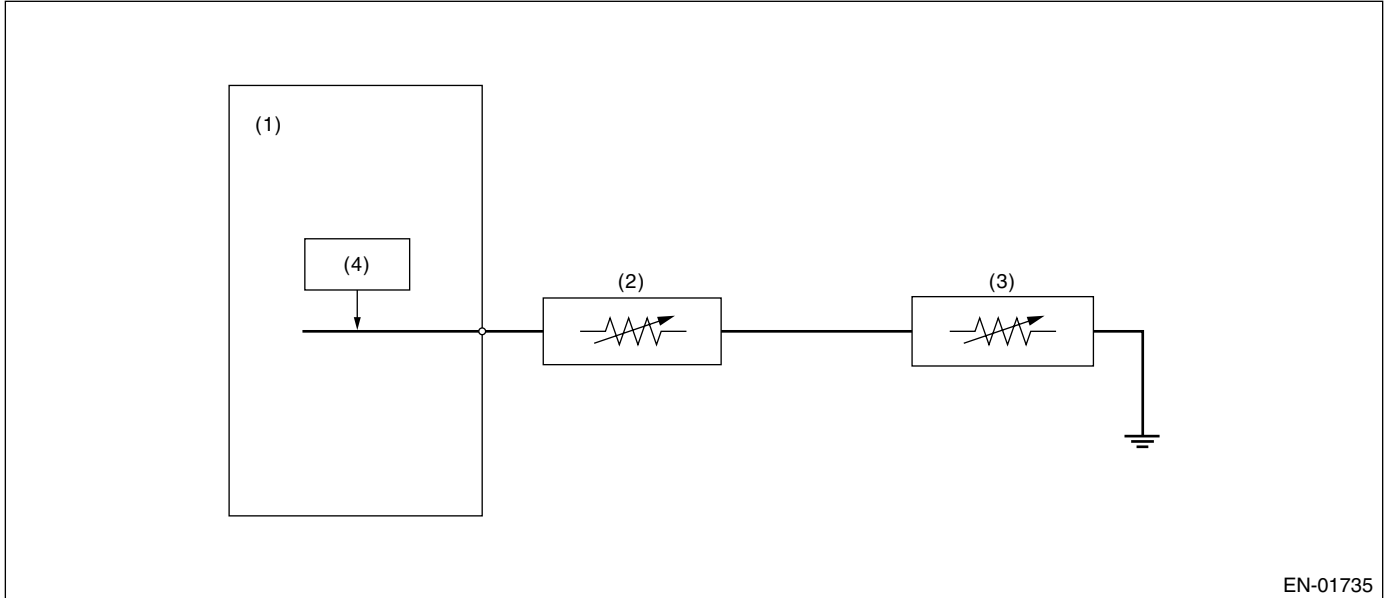

- (1) Engine control module (ECM)
- (2) Fuel level sensor
- (3) Fuel sub level sensor
- (4) Detecting circuit

EN-01735

3. ENABLE CONDITION

Secondary Parameters	Enable Conditions
None	

4. GENERAL DRIVING CYCLE

Always perform the diagnosis continuously

5. DIAGNOSTIC METHOD

• Abnormality Judgment

Judge NG when the continuous time of completing the malfunction criteria below becomes more than the time needed for diagnosis (2.5 seconds).

Judgment Value

Malfunction Criteria	Threshold Value
Ignition switch	ON
Battery voltage	$\geq 10.9 \text{ V}$
After engine starting	3 seconds or more
Output voltage	$< 0.035 \text{ V}$

Time Needed for Diagnosis: 2.5 seconds

Malfunction Indicator Light Illumination: Illuminates when malfunction occurs in 2 continuous driving cycles.

Diagnostic Trouble Code (DTC) Detecting Criteria

GENERAL DESCRIPTION

• Normality Judgment

Judge OK and clear the NG when the malfunction criteria below are completed.

Judgment Value

Malfunction Criteria	Threshold Value
Ignition switch	ON
Battery voltage	≥ 10.9 V
After engine starting	3 seconds or more
Output voltage	≥ 0.035 V

6. DTC CLEAR CONDITION

- When the OK idling cycle was completed 40 times in a row
- When "Clear Memory" was performed

7. MALFUNCTION INDICATOR LIGHT CLEAR CONDITION

- When the OK driving cycle was completed 3 times in a row
- When "Clear Memory" was performed

8. FAIL SAFE

None

9. ECM OPERATION AT DTC SETTING

Memorize the freeze frame data. (For test mode \$02)

Diagnostic Trouble Code (DTC) Detecting Criteria

GENERAL DESCRIPTION

BW:DTC P0463 FUEL LEVEL SENSOR CIRCUIT HIGH INPUT

1. OUTLINE OF DIAGNOSIS

Detect the open or short circuit of fuel level sensor. Judge NG when out of the standard value.

2. COMPONENT DESCRIPTION

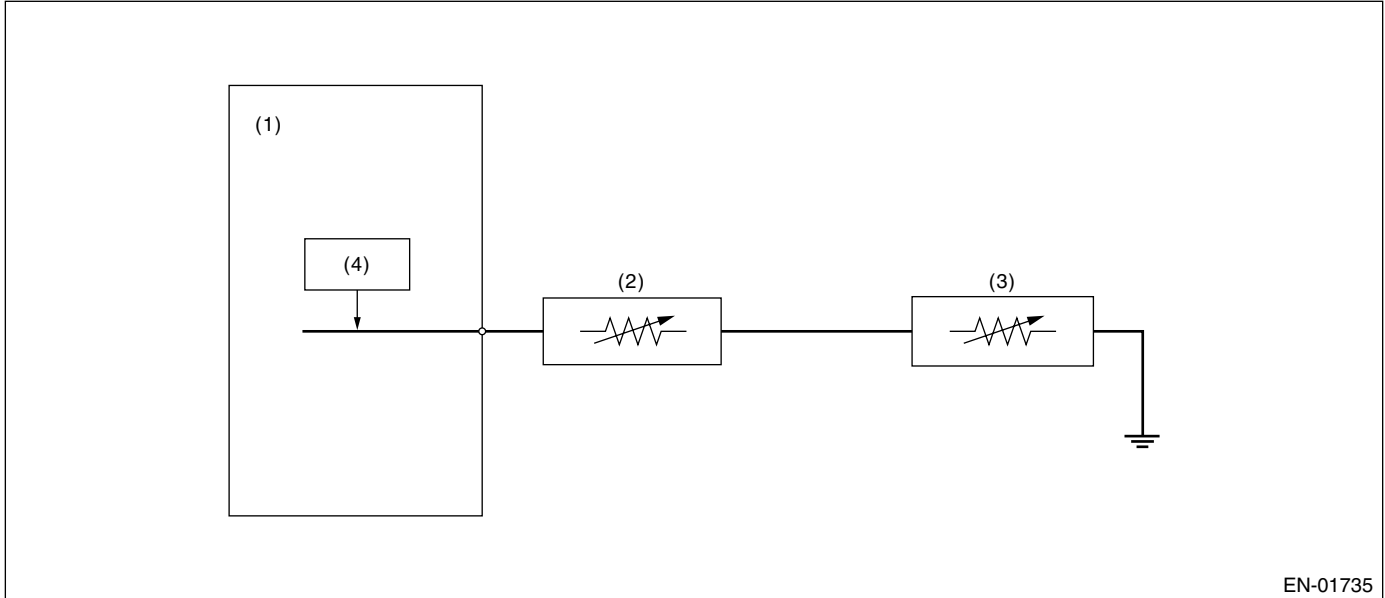

- (1) Engine control module (ECM)
- (2) Fuel level sensor
- (3) Fuel sub level sensor
- (4) Detecting circuit

3. ENABLE CONDITION

Secondary Parameters	Enable Conditions
None	

4. GENERAL DRIVING CYCLE

Always perform the diagnosis continuously

5. DIAGNOSTIC METHOD

• Abnormality Judgment

Judge NG when the continuous time of completing the malfunction criteria below becomes more than the time needed for diagnosis (10 seconds).

Judgment Value

Malfunction Criteria	Threshold Value
Ignition switch	ON
Battery voltage	$\geq 10.9 \text{ V}$
After engine starting	3 seconds or more
Output voltage	$\geq 4.911 \text{ V}$

Time Needed for Diagnosis: 10 seconds

Malfunction Indicator Light Illumination: Illuminates when malfunction occurs in 2 continuous driving cycles.

Diagnostic Trouble Code (DTC) Detecting Criteria

GENERAL DESCRIPTION

• Normality Judgment

Judge OK and clear the NG when the malfunction criteria below are completed.

Judgment Value

Malfunction Criteria	Threshold Value
Ignition switch	ON
Battery voltage	≥ 10.9 V
After engine starting	3 seconds or more
Output voltage	< 4.911 V

6. DTC CLEAR CONDITION

- When the OK idling cycle was completed 40 times in a row
- When "Clear Memory" was performed

7. MALFUNCTION INDICATOR LIGHT CLEAR CONDITION

- When the OK driving cycle was completed 3 times in a row
- When "Clear Memory" was performed

8. FAIL SAFE

None

9. ECM OPERATION AT DTC SETTING

Memorize the freeze frame data. (For test mode \$02)

BX:DTC P0464 FUEL LEVEL SENSOR CIRCUIT INTERMITTENT

1. OUTLINE OF DIAGNOSIS

Detect the malfunction of unstable output from fuel level sensor caused by noise.

Judge NG when the max. value and cumulative value of output voltage variation of fuel level sensor is larger than the threshold value.

2. ENABLE CONDITION

Secondary Parameters	Enable Conditions
Engine speed	≥ 500 rpm
After engine starting	1 second or more
Ignition switch	ON
Battery voltage	> 10.9 V
Idle switch	ON
Fuel level	9 \longleftrightarrow 51 ℓ (2.4 \longleftrightarrow 13.4 US gal, 1.98 \longleftrightarrow 11.2 Imp gal)
Vehicle speed = 0 km/h (0 MPH)	10 seconds or more

3. GENERAL DRIVING CYCLE

- Perform the diagnosis continuously in idling condition.
- Pay attention to the fuel level.

Diagnostic Trouble Code (DTC) Detecting Criteria

GENERAL DESCRIPTION

4. DIAGNOSTIC METHOD

Calculate the Max. value (delflmax) and cumulative value (sumfl) of output voltage variation of fuel level sensor during 12.8 seconds. Judge it normal when both max. and cumulative values are not over the threshold value. Otherwise, when either of them is over the threshold value, count the diagnosis counter up. And judge NG if the counter indicated 4 counts.

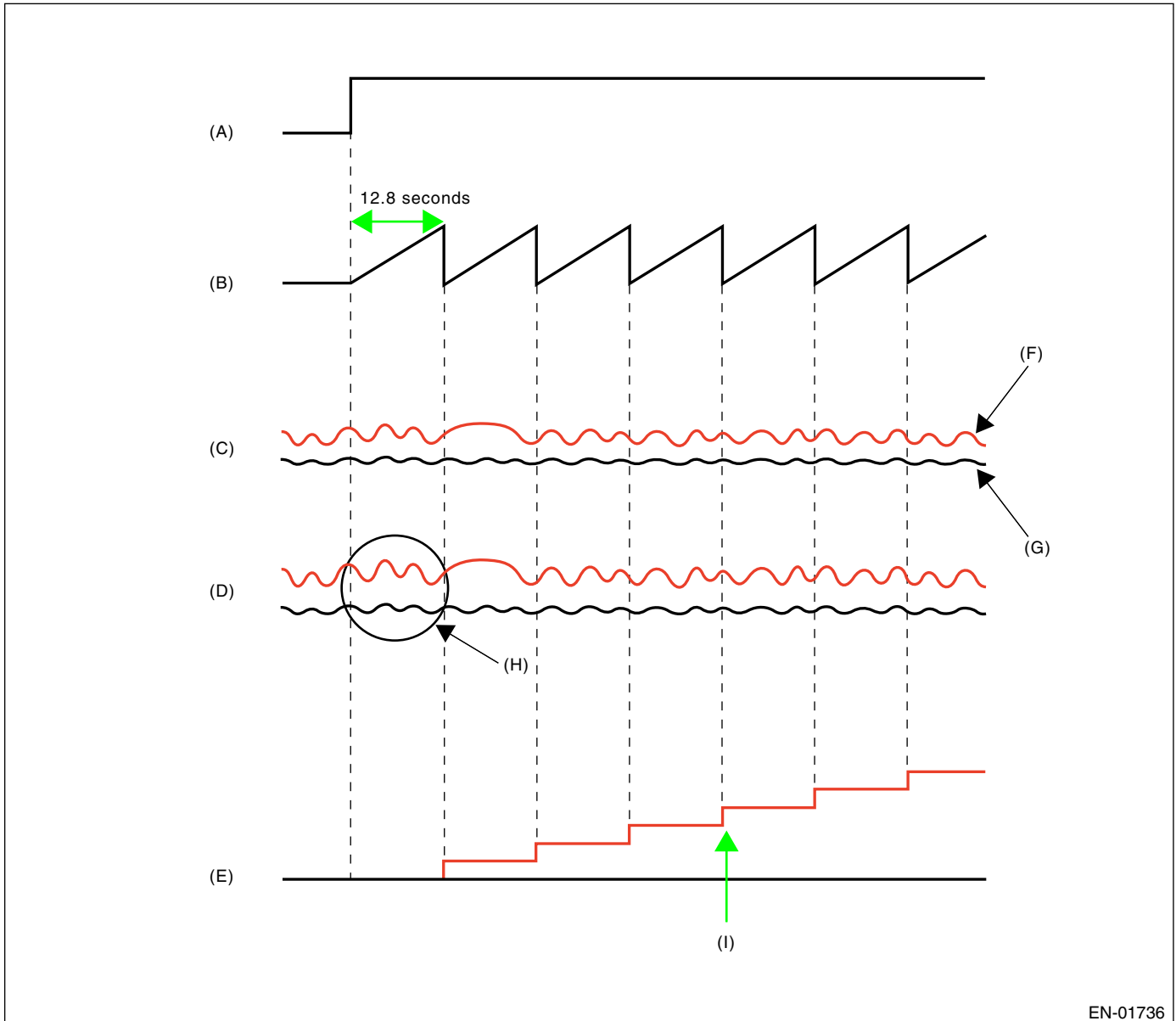

(A) Diagnosis condition

(B) Diagnosis time

(C) Fuel level sensor A/D value

(D) Fuel level output voltage

(E) Diagnosis counter

(F) Malfunction

(G) Normal

(H) Judge value of DVFLMAX and SUMVFL as maximum

(I) NG at 4 counts

Diagnostic Trouble Code (DTC) Detecting Criteria

GENERAL DESCRIPTION

• Abnormality Judgment

Judge NG when the malfunction criteria below are completed.

Judgment Value

Malfunction Criteria	Threshold Value
Integrated times of the condition reaching follows, DELFLMAX \geq 0.228 V or SUMVFL \geq 21.8 V where, DELFLMAX is Max. deviation of sensor output during 12.8 seconds. SUMVFL is integrated value of sensor output deviation during 12.8 seconds.	\geq 4 times

Do not count the diagnosis counter up when the following conditions are completed during 12.8 seconds.

Max – Min of tank pressure during 12.8 seconds	\geq 0.05 kPa (0.375 mmHg, 0.01 inHg)
Max – Min of battery voltage during 12.8 seconds	\geq 0.465 V

Time Needed for Diagnosis: 12.8 seconds \times 4 times

Malfunction Indicator Light Illumination: Illuminates when malfunction occurs in 2 continuous driving cycles.

• Normality Judgment

Judge OK and clear the NG when the malfunction criteria below are completed.

Judgment Value

Malfunction Criteria	Threshold Value
DELFLMAX	$<$ 0.228 V
SUMVFL	$<$ 21.8 V
Where, DELFLMAX is Max. deviation of sensor output during 12.8 seconds. SUMVFL is integrated value of sensor output deviation during 12.8 seconds.	

5. DTC CLEAR CONDITION

- When the OK idling cycle was completed 40 times in a row
- When "Clear Memory" was performed

6. MALFUNCTION INDICATOR LIGHT CLEAR CONDITION

- When the OK driving cycle was completed 3 times in a row
- When "Clear Memory" was performed

7. FAIL SAFE

None

8. ECM OPERATION AT DTC SETTING

Memorize the freeze frame data. (For test mode \$02)

Diagnostic Trouble Code (DTC) Detecting Criteria

GENERAL DESCRIPTION

BY:DTC P0483 COOLING FAN RATIONALITY CHECK

1. OUTLINE OF DIAGNOSIS

Detect the function abnormality of the radiator fan.

Judge NG when the engine coolant temperature slowly decreases even when the radiator fan is rotating.

2. ENABLE CONDITION

Diagnostic enable condition is completed if the radiator fan changes from OFF to ON when all of the conditions below are completed. When one of the conditions below is not completed, the diagnostic enable condition is not completed.

Secondary Parameters	Enable Conditions
Engine Speed	550 — 950 rpm
Idle switch	ON
Vehicle speed	0 km/h (0 MPH)
Battery voltage	≥ 10.9 V

3. GENERAL DRIVING CYCLE

Perform the diagnosis continuously when idling.

4. DIAGNOSTIC METHOD

• Abnormality Judgment

Judge NG when the continuous time of completing the malfunction criteria below becomes more than 5 minutes.

Judgment Value

Malfunction Criteria	Threshold Value
Engine coolant temperature	≥ 95°C (203°F)
Radiator fan signal change	OFF to ON
Engine coolant temperature	Not decrease

Time Needed for Diagnosis: 5 minutes

Malfunction Indicator Light Illumination: Illuminates when malfunction occurs in 2 continuous driving cycles.

• Normality Judgment

Judge OK and clear NG when the malfunction criteria below are completed.

Judgment Value

Malfunction Criteria	Threshold Value
Radiator fan signal change	OFF to ON
Engine coolant temperature	Decrease

5. DTC CLEAR CONDITION

- When the OK idling cycle was completed 40 times in a row
- When "Clear Memory" was performed

6. MALFUNCTION INDICATOR LIGHT CLEAR CONDITION

- When the OK driving cycle was completed 3 times in a row
- When "Clear Memory" was performed

7. FAIL SAFE

None

8. ECM OPERATION AT DTC SETTING

Memorize the freeze frame data. (For test mode \$02)

Diagnostic Trouble Code (DTC) Detecting Criteria

GENERAL DESCRIPTION

BZ:DTC P0502 VEHICLE SPEED SENSOR CIRCUIT LOW INPUT

1. OUTLINE OF DIAGNOSIS

Detect the open or short circuit of vehicle speed sensor.

Judge NG when low vehicle speed (0 km/h (0 MPH)) remains whereas it seemed to be in a usual driving speed.

2. ENABLE CONDITION

Secondary Parameters	Enable Conditions
Engine speed	< 4,000 rpm
Fuel cut in decel.	Operating
Battery voltage	≥ 10.9 V

3. GENERAL DRIVING CYCLE

Perform the diagnosis continuously during fuel cut in deceleration at less than 4,000 rpm in engine speed.

4. DIAGNOSTIC METHOD

• Abnormality Judgment

Judge NG when the continuous time of completing the malfunction criteria below becomes more than 4 seconds.

Judgment Value

Malfunction Criteria	Threshold Value
Vehicle speed	< 1

Time Needed for Diagnosis: 4 seconds

Malfunction Indicator Light Illumination: Illuminates as soon as the malfunction occurs.

• Normality Judgment

Judge OK and clear the NG when all malfunction criteria below are completed.

Judgment Value

Malfunction Criteria	Threshold Value
Vehicle speed	≥ 1
Starter switch	OFF
Time after starter switch ON → OFF	≥ 3 seconds

5. DTC CLEAR CONDITION

- When the OK idling cycle was completed 40 times in a row
- When "Clear Memory" was performed

6. MALFUNCTION INDICATOR LIGHT CLEAR CONDITION

- When the OK driving cycle was completed 3 times in a row
- When "Clear Memory" was performed

7. FAIL SAFE

- Accelerator sensor signal process: All closed points learning / Not allowed to increase.
- Vehicle speed sensor signal process: Vehicle speed = 10 km/h (6.21 MPH)
- Fuel cut control: Not allowed vehicle speed 0 km/h (0 MPH) fuel cut. Normally the high vehicle speed fuel cut performs on "and" of vehicle speed condition and engine speed, but perform the fuel cut only on engine speed condition (4,800 rpm or more).
- ISC control: Set the open loop compensation to specified value (1 g/s). Not allowed ISC feedback volume calculation.
- Air conditioner control: Not allowed air conditioner cut at accelerating.
- Radiator fan control: Hi driven both main/sub.
- Judge gear ratio: Control as gear fixed on 6th.
- Tumble generator valve control: Open the tumble generator valve.

Diagnostic Trouble Code (DTC) Detecting Criteria

GENERAL DESCRIPTION

8. ECM OPERATION AT DTC SETTING

Memorize the freeze frame data. (For test mode \$02)

CA:DTC P0503 VEHICLE SPEED SENSOR INTERMITTENT/ERRATIC/HIGH

1. OUTLINE OF DIAGNOSIS

Detect the open or short circuit of vehicle speed sensor.

Judge NG when high vehicle speed (300 km/h (186.4 MPH) or more) remains whereas it seemed to be in a usual driving speed.

2. ENABLE CONDITION

Secondary Parameters	Enable Conditions
Engine speed	< 4,000 rpm
Fuel cut in decel.	Operating
Battery voltage	≥ 10.9 V

3. GENERAL DRIVING CYCLE

Perform the diagnosis continuously during fuel cut in deceleration at less than 4,000 rpm in engine speed.

4. DIAGNOSTIC METHOD

• Abnormality Judgment

Judge NG when the cumulative time of completing the malfunction criteria below becomes more than 4 seconds.

Judgment Value

Malfunction Criteria	Threshold Value
Vehicle speed	≥ 300

Time Needed for Diagnosis: 4 seconds

Malfunction Indicator Light Illumination: Illuminates as soon as the malfunction occurs.

• Normality Judgment

Judge OK and clear the NG when all malfunction criteria below are completed.

Judgment Value

Malfunction Criteria	Threshold Value
Vehicle speed	< 300 km/h (186.4 MPH)
Starter switch	OFF
Time after starter switch ON → OFF	≥ 3 seconds

5. DTC CLEAR CONDITION

- When the OK idling cycle was completed 40 times in a row
- When "Clear Memory" was performed

6. MALFUNCTION INDICATOR LIGHT CLEAR CONDITION

- When the OK driving cycle was completed 3 times in a row
- When "Clear Memory" was performed

Diagnostic Trouble Code (DTC) Detecting Criteria

GENERAL DESCRIPTION

7. FAIL SAFE

- Vehicle speed sensor signal process: Vehicle speed = 10 km/h (6.21 MPH)
- Fuel cut control: Not allowed vehicle speed 0 km/h (0 MPH) fuel cut. Normally the high vehicle speed fuel cut performs on “and” of vehicle speed condition and engine speed, but perform the fuel cut only on engine speed condition (4,800 rpm or more).
- ISC control: Set the open loop compensation to specified value (1 g/s). Not allowed ISC feedback volume calculation.
- Air conditioner control: Not allowed air conditioner cut at accelerating.
- Radiator fan control: Hi driven both main/sub.
- Judge gear ratio: Control as gear fixed on 6th.
- Tumble generator valve control: Open the tumble generator valve.

8. ECM OPERATION AT DTC SETTING

Memorize the freeze frame data. (For test mode \$02)

Diagnostic Trouble Code (DTC) Detecting Criteria

GENERAL DESCRIPTION

CB:DTC P0506 IDLE AIR CONTROL SYSTEM RPM LOWER THAN EXPECTED

1. OUTLINE OF DIAGNOSIS

Detect the malfunction that actual engine speed is not close to target engine speed during idling.
Judge NG when actual engine speed is not close to target engine speed during idling.

2. ENABLE CONDITION

Secondary Parameters	Enable Conditions
Engine coolant temperature	≥ 70°C (158°F)
Battery voltage	≥ 10.9 V
Atmospheric pressure	> 75.0 kPa (563 mmHg, 22.2 inHg)
Fuel level	≥ 9 ℓ (2.38 US gal, 1.98 Imp gal)
After starting engine	10 seconds or more
Feedback in ISC	In operation
Measured lambda	0.90 ←→ 1.1
After air condition switching ON-OFF, OFF-ON	5 seconds or more
After in-manifold pressure change more than 4 kPa (30 mmHg, 1.2 inHg)	> 5 seconds
After neutral switch ON-OFF event	> 5 seconds
Vehicle speed	0 km/h (0 MPH)

3. GENERAL DRIVING CYCLE

Perform the diagnosis continuously during idling.

4. DIAGNOSTIC METHOD

• Abnormality Judgment

Judge NG when the cumulative time of completing the malfunction criterion below becomes more than the time needed for diagnosis (10 seconds × 3 times).

Judgment Value

Malfunction Criteria	Threshold Value
Actual – target engine speed	< –100 rpm
Feedback correction for idle air control solenoid valve	Max.

Time Needed for Diagnosis: 10 seconds × 3 times

Malfunction Indicator Light Illumination: Illuminates when malfunction occurs in 2 continuous driving cycles.

• Normality Judgment

Judge OK and clear NG when the continuous time of completing the malfunction criterion below becomes more than the time needed for diagnosis (10 seconds).

Judgment Value

Malfunction Criteria	Threshold Value
Actual – target engine speed	≥ –100 rpm

5. DTC CLEAR CONDITION

- When the OK idling cycle was completed 40 times in a row
- When “Clear Memory” was performed

6. MALFUNCTION INDICATOR LIGHT CLEAR CONDITION

- When the OK driving cycle was completed 3 times in a row
- When “Clear Memory” was performed

Diagnostic Trouble Code (DTC) Detecting Criteria

GENERAL DESCRIPTION

7. FAIL SAFE

- Heavy fuel judgment: Not allowed to carry out the heavy judgment
- Knock compensation:
 - Knock compensation final timing advance and retard value = knock compensation + whole learning compensation value + partial learning compensation value.
 - At normal: knock compensation = 0°CA is fixed.
 - At trouble: knock compensation ≠ 0°CA is fixed. (Retard max. 12°CA at knock.)
 - Not allowed to update the whole learning compensation factor.
 - Not allowed to calculate the partial learning zone compensation value.

8. ECM OPERATION AT DTC SETTING

Memorize the freeze frame data. (For test mode \$02)

Diagnostic Trouble Code (DTC) Detecting Criteria

GENERAL DESCRIPTION

CC:DTC P0507 IDLE AIR CONTROL SYSTEM RPM HIGHER THAN EXPECTED

1. OUTLINE OF DIAGNOSIS

Detect the malfunction that actual engine speed is not close to target engine speed during idling.
Judge NG when actual engine speed is not close to target engine speed during idling.

2. ENABLE CONDITION

Secondary Parameters	Enable Conditions
Engine coolant temperature	≥ 70°C (158°F)
Battery voltage	≥ 10.9 V
Atmospheric pressure	> 75.0 kPa (563 mmHg, 22.2 inHg)
Fuel level	≥ 9 ℓ (2.38 US gal, 1.98 Imp gal)
After starting engine	10 seconds or more
Feedback in ISC	In operation
Lambda	0.90 ←→ 1.1
After air condition switching ON-OFF, OFF-ON	5 seconds or more
After in-manifold pressure change more than 4 kPa (30 mmHg, 1.2 inHg)	> 5 seconds
After neutral switch ON-OFF event	> 5 seconds
Vehicle speed	0 km/h (0 MPH)

3. GENERAL DRIVING CYCLE

Perform the diagnosis continuously 10 seconds after starting and at idling after warm-up.

4. DIAGNOSTIC METHOD

• Abnormality Judgment

Judge NG when the continuous time of completing the malfunction criterion below becomes more than the time needed for diagnosis (10 seconds × 3 times).

Judgment Value

Malfunction Criteria	Threshold Value
Actual – target eng. speed	≥ 200 rpm
Feedback correction for idle air control solenoid valve	Min.

Time Needed for Diagnosis: 10 seconds × 3 times

Malfunction Indicator Light Illumination: Illuminates when malfunction occurs in 2 continuous driving cycles.

• Normality Judgment

Judge OK and clear NG when the continuous time of completing the malfunction criterion below becomes more than the time needed for diagnosis (10 seconds).

Judgment Value

Malfunction Criteria	Threshold Value
Actual – target eng. speed	< 200 rpm

5. DTC CLEAR CONDITION

- When the OK idling cycle was completed 40 times in a row
- When “Clear Memory” was performed

6. MALFUNCTION INDICATOR LIGHT CLEAR CONDITION

- When the OK driving cycle was completed 3 times in a row
- When “Clear Memory” was performed

Diagnostic Trouble Code (DTC) Detecting Criteria

GENERAL DESCRIPTION

7. FAIL SAFE

- Heavy fuel judgment: Not allowed to carry out the heavy judgment
- Knock compensation:
 - Knock compensation final timing advance and retard value = knock compensation + whole learning compensation value + partial learning compensation value.
 - At normal: knock compensation = 0°CA is fixed.
 - At trouble: knock compensation ≠ 0°CA is fixed. (Retard max. 12°CA at knock.)
 - Not allowed to update the whole learning compensation factor.
 - Not allowed to calculate the partial learning zone compensation value.

8. ECM OPERATION AT DTC SETTING

Memorize the freeze frame data. (For test mode \$02)

Diagnostic Trouble Code (DTC) Detecting Criteria

GENERAL DESCRIPTION

CD:DTC P0512 STARTER REQUEST CIRCUIT

1. OUTLINE OF DIAGNOSIS

Detect the open or short circuit of starter SW.

Judge ON NG when the starter SW signal remains on.

Judge OFF NG when the engine starts without starter experience.

2. ENABLE CONDITION

Secondary Parameters	Enable Conditions
None	

3. GENERAL DRIVING CYCLE

Always perform the diagnosis continuously.

4. DIAGNOSTIC METHOD

• Abnormality Judgment

Judge NG when the continuous time of completing the malfunction criteria below becomes more than 3 minutes.

Judgment Value

Malfunction Criteria	Threshold Value
Engine speed	> 500 rpm
Starter OFF signal	Not detected
Battery voltage	> 8 V

Time Needed for Diagnosis: 180 seconds

Malfunction Indicator Light Illumination: Illuminates when malfunction occurs in 2 continuous driving cycles.

• Normality Judgment

Judge ON OK and clear the NG when the malfunction criteria below are completed.

Judgment Value

Malfunction Criteria	Threshold Value
Starter SW	OFF
Battery voltage	> 8 V

5. DTC CLEAR CONDITION

- When the OK idling cycle was completed 40 times in a row
- When "Clear Memory" was performed

6. MALFUNCTION INDICATOR LIGHT CLEAR CONDITION

- When the OK driving cycle was completed 3 times in a row
- When "Clear Memory" was performed

7. FAIL SAFE

None

8. ECM OPERATION AT DTC SETTING

Memorize the freeze frame data. (For test mode \$02)

Diagnostic Trouble Code (DTC) Detecting Criteria

GENERAL DESCRIPTION

CE:DTC P0513 INCORRECT IMMOBILIZER KEY

1. OUTLINE OF DIAGNOSIS

DTC	ITEM	OUTLINE OF DIAGNOSIS
P0513	Incorrect Immobilizer Key	Incorrect immobilizer key (Use of key not registered in body integrated module)
P1570	Antenna	Improper antenna
P1571	Reference Code Incompatibility	Unmatched reference code between body integrated module and ECM
P1572	IMM Circuit Failure (Except Antenna Circuit)	Communication malfunction between body integrated module and ECM
P1574	Key Communication Failure	Malfunction of body integrated module that check the key (transponder) ID or transponder failure.
P1576	EGI Control Module EEPROM	Abnormality of ECM
P1577	IMM Control Module EEPROM	Malfunction of body integrated module.
P1578	Meter Failure	Unmatched reference code between body integrated module and combination meter.

2. ENABLE CONDITION

When the engine is started.

3. GENERAL DRIVING CYCLE

Perform the diagnosis only when the engine is started.

4. DIAGNOSTIC METHOD

Jude NG when the outline diagnosis above was completed.

Diagnostic Trouble Code (DTC) Detecting Criteria

GENERAL DESCRIPTION

CF:DTC P0519 IDLE CONTROL SYSTEM MALFUNCTION (FAIL-SAFE)

1. OUTLINE OF DIAGNOSIS

Detect the malfunction that engine speed increases more than that in normal condition during idling.

2. ENABLE CONDITION

Secondary Parameters	Enable Conditions
Battery voltage	≥ 10.9 V
Feedback in ISC	In operation
Vehicle speed	< 4 km/h (2.49 MPH)
After engine starting	1 seconds or more

3. GENERAL DRIVING CYCLE

Always perform diagnosis at less than 4 km/h (2.49 MPH) of vehicle speed.

4. DIAGNOSTIC METHOD

• Abnormality Judgment

Judge NG when the continuous time until completing the all malfunction criteria below becomes more than the time needed for diagnosis (2 seconds).

Judgment Value

Malfunction Criteria	Threshold Value
Engine speed – target eng. speed	≥ 1,500 rpm
Feedback value for ISC	≤ 0%
Engine speed change every 180 degree engine rev.	≥ -5 rpm

Time Needed for Diagnosis: 2 seconds

Malfunction Indicator Light Illumination: Illuminates as soon as malfunction occurs.

• Normality Judgment

Judge OK and clear NG when the continuous time until completing the malfunction criteria below becomes more than the time needed for diagnosis (5 seconds).

Judgment Value

Malfunction Criteria	Threshold Value
Engine speed – target eng. speed	< 200 rpm

5. DTC CLEAR CONDITION

- When the OK idling cycle was completed 40 times in a row
- When “Clear Memory” was performed

6. MALFUNCTION INDICATOR LIGHT CLEAR CONDITION

- When the OK driving cycle was completed 3 times in a row
- When “Clear Memory” was performed

7. FAIL SAFE

Fuel shut-off: Shut-off fuel for only #1 and #2 cylinder, or for all cylinder in accordance with vehicle speed, engine speed, throttle position

8. ECM OPERATION AT DTC SETTING

Memorize the freeze frame data. (For test mode \$02)

Diagnostic Trouble Code (DTC) Detecting Criteria

GENERAL DESCRIPTION

CG:DTC P0600 SERIAL COMMUNICATION LINK

1. OUTLINE OF DIAGNOSIS

Detect the malfunction of CAN communication.

Judge NG when CAN communication becomes impossible, the CAN communication with AT becomes impossible, and the data from AT is not normal.

2. COMPONENT DESCRIPTION

CAN connects between ECM and TCM with high speed.

(Common Specification)

CAN PROTOCOL 2.0B (active)

Frame format: 11 bit ID Frame (Standard frame)

(High Speed CAN)

ISO 11898 compliance

Communication Speed: 500 kbps

3. ENABLE CONDITION

Secondary Parameters	Enable Conditions
Battery Voltages	≥ 10.9 V
Starter switch	OFF
Engine	Run

4. GENERAL DRIVING CYCLE

Perform the diagnosis continuously after starting the engine.

5. DIAGNOSTIC METHOD

• JUDGMENT OF MALFUNCTION

Judge NG when any of the malfunction criteria below are completed. Judge OK and clear the NG when the continuous time of not completing all the malfunction criteria below becomes more than the time needed for diagnosis (1 second).

Judgement Value

Malfunction Criteria	Threshold Value
Buss off flag or warning flag	Set
ID cannot be received from TCM	= 500 milliseconds

Time needed for Diagnosis: 1 second

Malfunction Indicator Light Illumination: Illuminates simultaneously when malfunction is detected.

6. DTC CLEAR CONDITION

When the OK driving cycle was completed 40 consecutive times.

When "Clear Memory" was performed.

7. MALFUNCTION INDICATOR LIGHT CLEAR CONDITION

- When the OK driving cycle was completed 3 consecutive times.
- When "Clear Memory" was performed.

8. FAIL-SAFE

The angle operation of accelerator position sensor demand target throttle opening calculation

9. ECM OPERATION AT DTC SETTING

Store the freeze frame data. (For test mode \$02)

Diagnostic Trouble Code (DTC) Detecting Criteria

GENERAL DESCRIPTION

CH:DTC P0604 INTERNAL CONTROL MODULE RANDOM ACCESS MEMORY (RAM) ERROR

1. OUTLINE OF DIAGNOSIS

Detect the function abnormality of the micro-computer (RAM).

Normally, zero-clear all the RAM area in the initial routine. And judge NG when the total of all the RAM after the clear is not \$0000.

2. ENABLE CONDITION

Secondary Parameters	Enable Conditions
Ignition switch	OFF → ON

Perform the diagnosis in the initial routine.

3. GENERAL DRIVING CYCLE

Perform the diagnosis immediately after IG key SW is turned ON.

4. DIAGNOSTIC METHOD

Judge NG when the malfunction criteria below are completed. Judge OK and clear NG when the malfunction criteria below are not completed.

Judgment Value

Malfunction Criteria	Threshold Value
Result of RAM data addition, after zero initialization	Cannot read

Time Needed for Diagnosis: Undecided

Malfunction Indicator Light Illumination: Illuminates as soon as malfunction occurs.

5. DTC CLEAR CONDITION

- When the OK idling cycle was completed 40 times in a row
- When "Clear Memory" was performed

6. MALFUNCTION INDICATOR LIGHT CLEAR CONDITION

- When the OK driving cycle was completed 3 times in a row
- When "Clear Memory" was performed

7. FAIL SAFE

None

8. ECM OPERATION AT DTC SETTING

Memorize the freeze frame data. (For test mode \$02)

Diagnostic Trouble Code (DTC) Detecting Criteria

GENERAL DESCRIPTION

CI: DTC P0605 INTERNAL CONTROL MODULE READ ONLY MEMORY (ROM) ERROR

1. OUTLINE OF DIAGNOSIS

Judge NG when SUM value of ROM is out of the standard value.

2. ENABLE CONDITION

Secondary Parameters	Enable Conditions
Ignition switch	ON

3. GENERAL DRIVING CYCLE

Always perform the diagnosis continuously.

4. DIAGNOSTIC METHOD

• Abnormality Judgment

Judge NG when the continuous time of completing the malfunction criteria below becomes more than 0.5 seconds.

Judgment Value

Malfunction Criteria	Threshold Value
SUM value of ROM	Standard value

Time Needed for Diagnosis: To be determined.

Malfunction Indicator Light Illumination: Illuminates as soon as malfunction occurs.

5. DTC CLEAR CONDITION

- When the OK idling cycle was completed 40 times in a row
- When "Clear Memory" was performed (Only at engine stop)

6. MALFUNCTION INDICATOR LIGHT CLEAR CONDITION

- When the OK driving cycle was completed 3 times in a row
- When "Clear Memory" was performed

7. FAIL SAFE

Stop the current to electronic throttle control motor. (Fix the throttle opening angle to 6°.)

8. ECM OPERATION AT DTC SETTING

Memorize the freeze frame data. (For test mode \$02)

CJ:DTC P0607 CONTROL MODULE PERFORMANCE

1. OUTLINE OF DIAGNOSIS

Judge NG when either the following is completed.

- When the read value of throttle position sensor 1 signal is mismatched between main CPU and sub CPU.
- When the read value of accelerator pedal position sensor 1 signal is mismatched between main CPU and sub CPU.
- When the sub CPU operates abnormally.
- When the communication between main CPU and sub CPU is abnormal.
- When the input amplifier circuit of throttle position sensor 1 is abnormal.
- When the cruise control cannot be canceled correctly.
- When the signal of brake SW1 and 2 is mismatched.
- When the directed angle from main CPU is abnormal.

2. COMPONENT DESCRIPTION

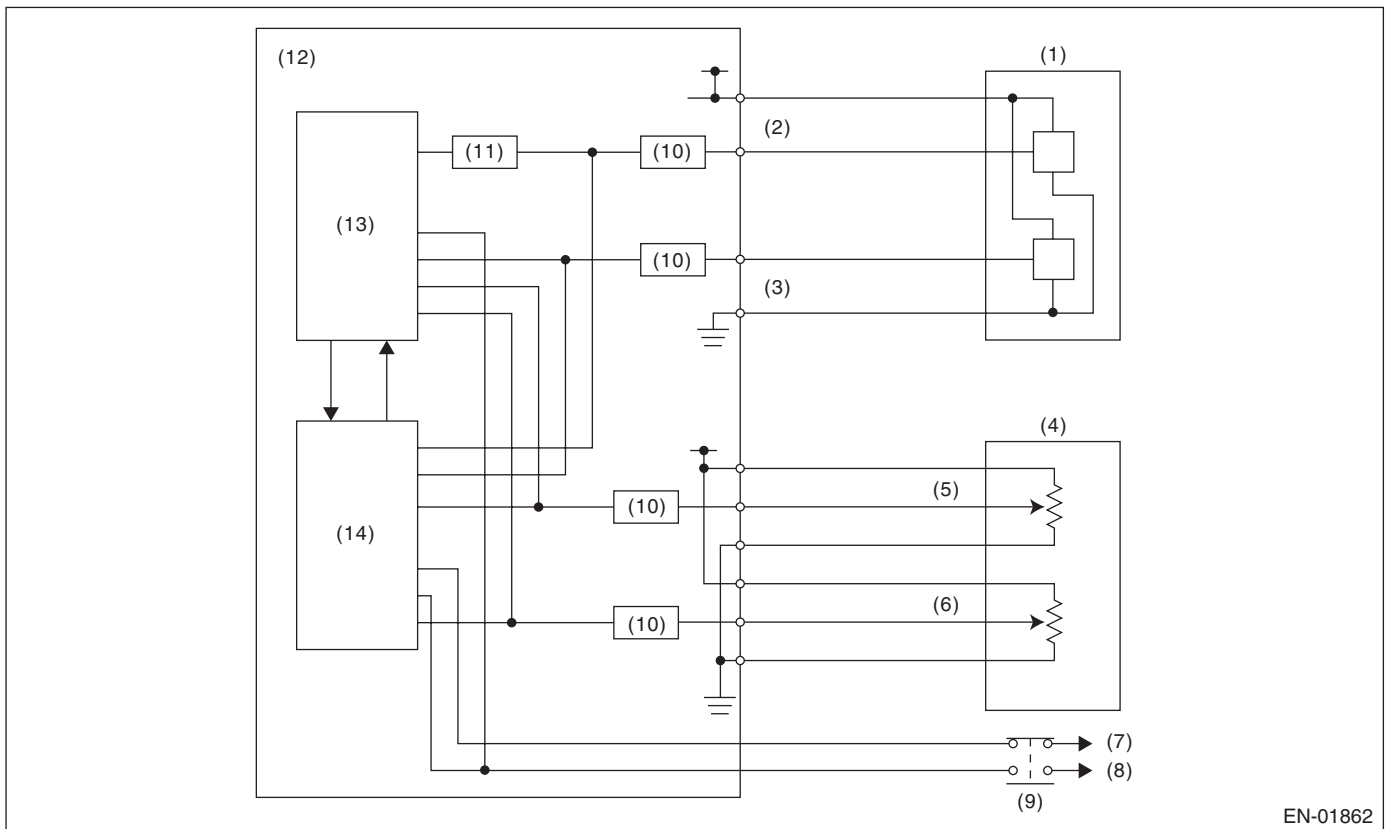

- | | | |
|---|---------------------------------------|----------------------------------|
| (1) Throttle position sensor | (6) Accelerator pedal position sensor | (11) Amplifier circuit |
| (2) Throttle position sensor 1 | (7) Battery | (12) Engine control module (ECM) |
| (3) Throttle position sensor 2 | (8) Stop light | (13) Sub CPU |
| (4) Accelerator pedal position sensor | (9) Brake switch | (14) Main CPU |
| (5) Accelerator pedal position sensor 1 | (10) I/F circuit | |

Diagnostic Trouble Code (DTC) Detecting Criteria

GENERAL DESCRIPTION

3. ENABLE CONDITION

Secondary Parameters	Enable Conditions
(1) Ignition switch	ON
(2) Ignition switch	ON
(3) None	—
(4) None	—
(5) Throttle opening angle	
(6) Brake SW (with cruise control)	ON
(7) None	—

4. GENERAL DRIVING CYCLE

- (1) — (4): Always perform the diagnosis continuously.
(5): Always perform the diagnosis continuously on idling.
(6): Perform the diagnosis when the brake pedal is depressed.
(7): Always perform the diagnosis continuously.

5. DIAGNOSTIC METHOD

Judge OK and clear NG when the malfunction criteria below are completed.

Judgment Value

Malfunction Criteria	Threshold Value
(1) Difference of CPU on reading value of throttle position sensor signal	Within 0.858 V
(2) Difference of CPU on reading value of accelerator position sensor signal	Within 0.042 V
(3) WD pulse from sub CPU	WD pulse occur
(4) Communication between CPU	Possible to communicate
(5) Difference of signal on connection of amplifier	Within $\times 4 \pm 3^\circ$
(6) Cruise control cancel signal at brake ON	Cruise control cancel signal ON
(7) Brake switch 1, 2 signal	SW 1 and 2 are matched

Time Needed for Diagnosis:

- (1) 250 milliseconds
(2) 250 milliseconds
(3) 200 milliseconds
(4) 200 milliseconds
(5) 24 milliseconds
(6) 250 milliseconds
(7) 200 milliseconds

Malfunction Indicator Light Illumination: Illuminates as soon as malfunction occurs.

6. DTC CLEAR CONDITION

- When the OK idling cycle was completed 40 times in a row
- When "Clear Memory" was performed

7. MALFUNCTION INDICATOR LIGHT CLEAR CONDITION

- When the OK driving cycle was completed 3 times in a row
- When "Clear Memory" was performed

8. FAIL SAFE

Stop the current to electronic throttle control motor. (Fix the throttle opening angle to 6° .)

9. ECM OPERATION AT DTC SETTING

Memorize the freeze frame data. (For test mode \$02)

CK:DTC P0638 THROTTLE ACTUATOR CONTROL RANGE/PERFORMANCE (BANK 1)

1. OUTLINE OF DIAGNOSIS

Judge NG when the target opening angle and actual opening angle is mismatched or the current to motor is more than specified duty for specified time continuously.

2. COMPONENT DESCRIPTION

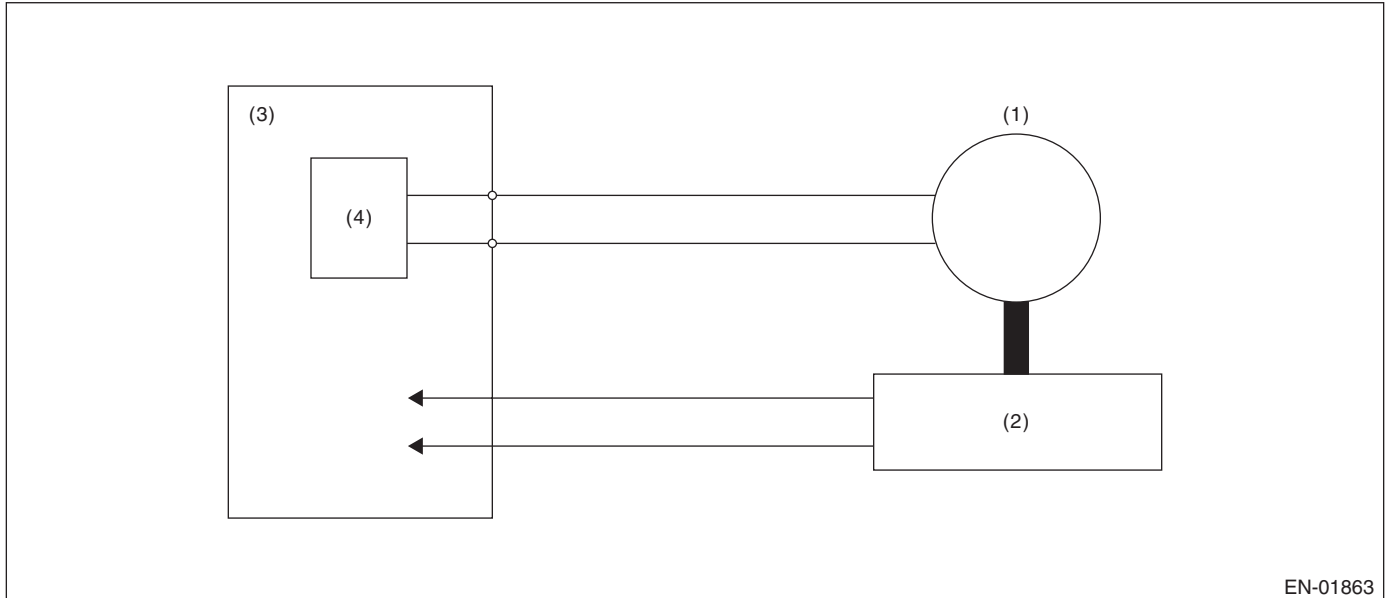

EN-01863

- | | |
|------------------------------|---------------------------------|
| (1) Motor | (3) Engine control module (ECM) |
| (2) Throttle position sensor | (4) Drive circuit |

3. ENABLE CONDITION

Secondary Parameters	Enable Conditions
Ignition switch	ON
Normal operation of electronic throttle control	ON

4. GENERAL DRIVING CYCLE

Always perform the diagnosis continuously when the electronic throttle control is operating.

5. DIAGNOSTIC METHOD

Judge OK and clear NG when the malfunction criteria below are completed.

Judgment Value

Malfunction Criteria	Threshold Value
Difference between target opening angle and actual opening angle	Less than 3.5°
Output duty to drive circuit	Less than 95%

Time Needed for Diagnosis:

Target opening angle and actual opening angle: 250 milliseconds (For NG) 2,000 milliseconds (For OK)
 Output duty to drive circuit: 2,000 milliseconds

Diagnostic Trouble Code (DTC) Detecting Criteria

GENERAL DESCRIPTION

Details of Judgment

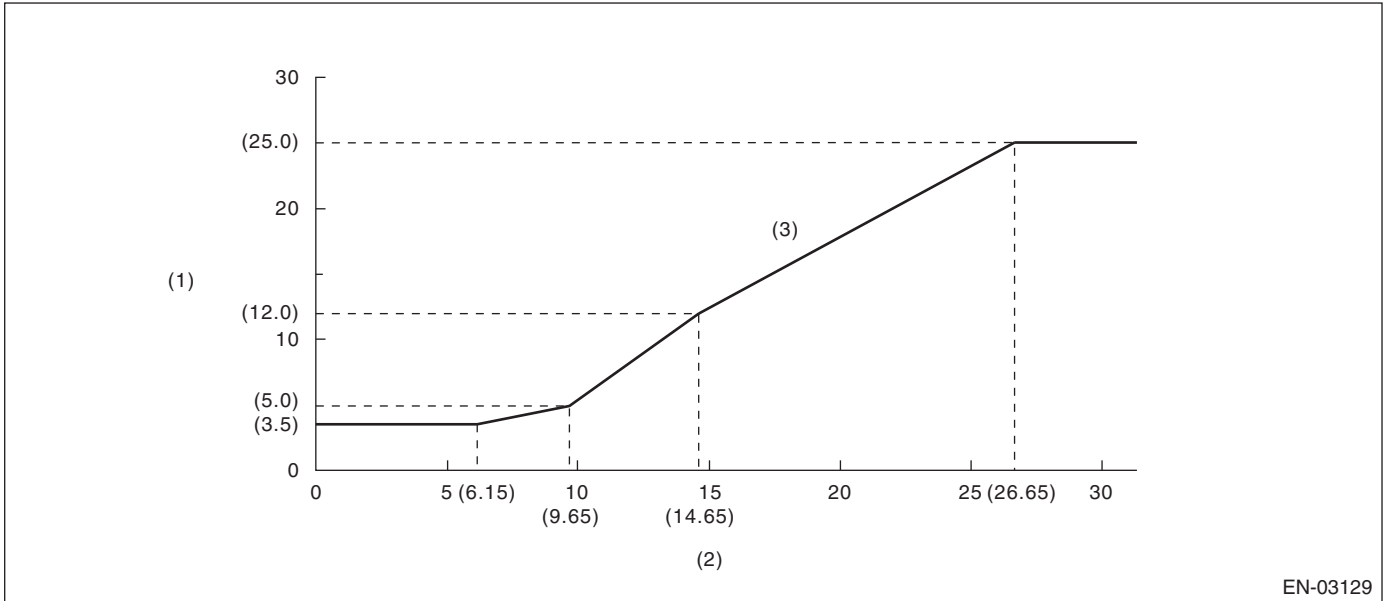

EN-03129

- (1) Difference between target opening angle and actual opening angle (°) (2) Target throttle opening angle (°)
 (3) NG area

Details of Judgment (Always 1,000 milliseconds when the actual opening angle ≤ target opening angle)

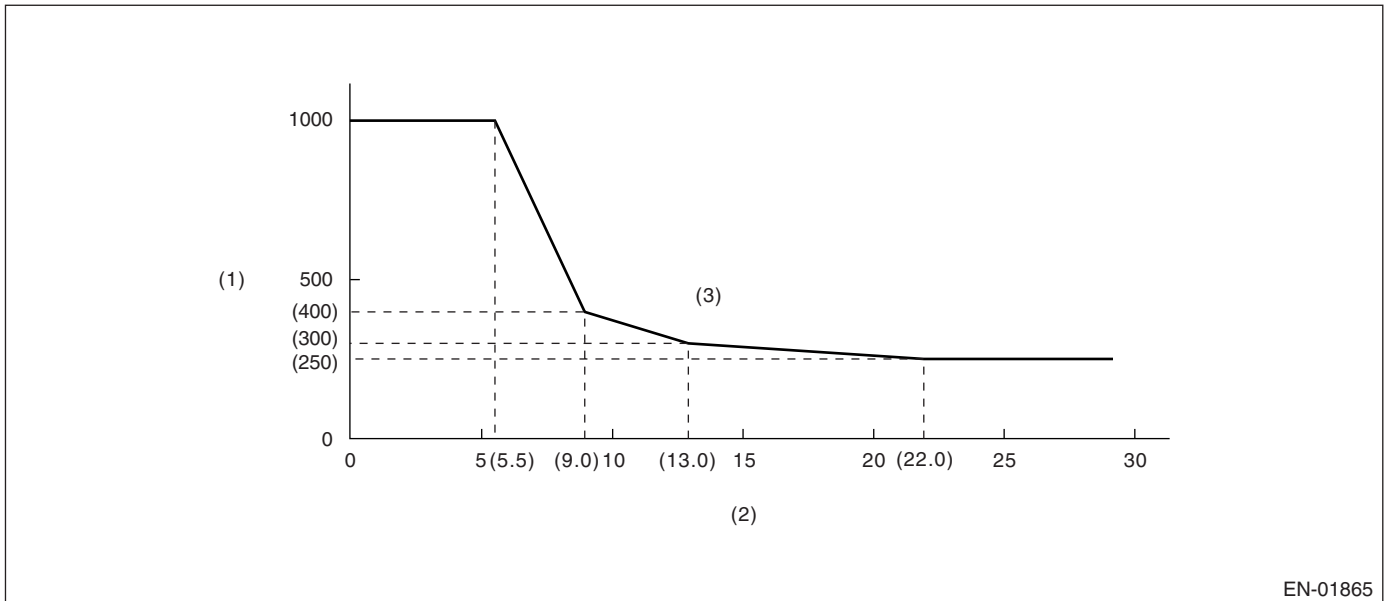

EN-01865

- (1) Judgment time (milliseconds) (3) NG area
 (2) Throttle position sensor 1 opening angle

Malfunction Indicator Light Illumination: Illuminates as soon as malfunction occurs.

6. DTC CLEAR CONDITION

- When the OK idling cycle was completed 40 times in a row
- When "Clear Memory" was performed (Only with engine stopped)

7. MALFUNCTION INDICATOR LIGHT CLEAR CONDITION

- When the OK driving cycle was completed 3 times in a row
- When "Clear Memory" was performed (Only with engine stopped)

Diagnostic Trouble Code (DTC) Detecting Criteria

GENERAL DESCRIPTION

8. FAIL SAFE

Stop the current to electronic throttle control motor. (Fix the throttle opening angle to 6°.)

9. ECM OPERATION AT DTC SETTING

Memorize the freeze frame data. (For test mode \$02)

CL:DTC P0691 COOLING FAN 1 CONTROL CIRCUIT LOW

1. OUTLINE OF DIAGNOSIS

Detect the open or short circuit of the radiator fan circuit.

Judge NG when the ECM output level differs from the actual terminal level.

2. ENABLE CONDITION

Secondary Parameters	Enable Conditions
None	

3. GENERAL DRIVING CYCLE

Always perform the diagnosis continuously.

4. DIAGNOSTIC METHOD

• Abnormality Judgment

Judge NG when the cumulative time of completing the malfunction criteria below becomes more than 2.5 seconds.

Judgment Value

Malfunction Criteria	Threshold Value
After starting the engine	1 seconds or more
Engine speed	≥ 500 rpm
Ignition switch	ON
Battery voltage	≥ 10.9 V
Terminal voltage level when ECM transmits OFF signal	Low level

Time Needed for Diagnosis: 2.5 seconds

Malfunction Indicator Light Illumination: Illuminates when malfunction occurs in 2 continuous driving cycles.

• Normality Judgment

Judge OK and clear NG when the malfunction criteria below are completed.

Judgment Value

Malfunction Criteria	Threshold Value
After starting the engine	1 seconds or more
Engine speed	≥ 500 rpm
Ignition switch	ON
Battery voltage	≥ 10.9 V
Terminal voltage level when ECM transmits OFF signal	High level

5. DTC CLEAR CONDITION

- When the OK idling cycle was completed 40 times in a row
- When "Clear Memory" was performed

6. MALFUNCTION INDICATOR LIGHT CLEAR CONDITION

- When the OK driving cycle was completed 3 times in a row
- When "Clear Memory" was performed

Diagnostic Trouble Code (DTC) Detecting Criteria

GENERAL DESCRIPTION

7. FAIL SAFE

None

8. ECM OPERATION AT DTC SETTING

Memorize the freeze frame data. (For test mode \$02)

CM:DTC P0692 COOLING FAN 1 CONTROL CIRCUIT HIGH

1. OUTLINE OF DIAGNOSIS

Detect the open or short circuit of the radiator fan circuit.

Judge NG when the ECM output level differs from the actual terminal level.

2. ENABLE CONDITION

Secondary Parameters	Enable Conditions
None	

3. GENERAL DRIVING CYCLE

Always perform the diagnosis continuously.

4. DIAGNOSTIC METHOD

• Abnormality Judgment

Judge NG when the cumulative time of completing the malfunction criteria below becomes more than 2.5 seconds.

Judgment Value

Malfunction Criteria	Threshold Value
After starting the engine	1 seconds or more
Engine speed	≥ 500 rpm
Ignition switch	ON
Battery voltage	≥ 10.9 V
Terminal voltage level when ECM transmits ON signal	High level

Time Needed for Diagnosis: 2.5 seconds

Malfunction Indicator Light Illumination: Illuminates when malfunction occurs in 2 continuous driving cycles.

• Normality Judgment

Judge OK and clear NG when the malfunction criteria below are completed.

Judgment Value

Malfunction Criteria	Threshold Value
After starting the engine	1 seconds or more
Engine speed	≥ 500 rpm
Ignition switch	ON
Battery voltage	≥ 10.9 V
Terminal voltage level when ECM transmits ON signal	Low level

5. DTC CLEAR CONDITION

- When the OK idling cycle was completed 40 times in a row
- When "Clear Memory" was performed

6. MALFUNCTION INDICATOR LIGHT CLEAR CONDITION

- When the OK driving cycle was completed 3 times in a row
- When "Clear Memory" was performed

Diagnostic Trouble Code (DTC) Detecting Criteria

GENERAL DESCRIPTION

7. FAIL SAFE

None

8. ECM OPERATION AT DTC SETTING

Memorize the freeze frame data. (For test mode \$02)

CN:DTC P0700 TRANSMISSION CONTROL SYSTEM (MIL REQUEST)

1. OUTLINE OF DIAGNOSIS

AT C/U performs CAN communication. It judges as NG if malfunction is detected.

2. ENABLE CONDITION

Secondary Parameters	Enable Conditions
Battery Voltage	≥ 10.9 V

3. GENERAL DRIVING CYCLE

Always perform diagnosis continuously.

4. DIAGNOSTIC METHOD

Judge NG when the continuous time of completing the malfunction criteria below becomes more than 2.5 seconds.

Judge OK and clear the NG when the malfunction criteria below are not completed.

Judgement Value

Malfunction Criteria	Threshold Value
MIL light up request from TCM	Set

Time needed for diagnosis: 2.5 seconds

Malfunction Indicator Light Illumination: Illuminates simultaneously when malfunction is detected.

5. DTC CLEAR CONDITION

- When the OK driving cycle was completed 40 consecutive times.
- When "Clear Memory" was performed.

6. MALFUNCTION INDICATOR LIGHT CLEAR CONDITION

- When the OK driving cycle was completed 3 consecutive times.
- When "Clear Memory" was performed.

7. FAIL-SAFE

None

8. ECM OPERATION AT DTC SETTING

Store the freeze frame data. (For test mode \$02)

Diagnostic Trouble Code (DTC) Detecting Criteria

GENERAL DESCRIPTION

CO:DTC P0851 NEUTRAL SWITCH INPUT CIRCUIT LOW (AT MODEL)

1. OUTLINE OF DIAGNOSIS

Detect the open or short circuit of the neutral SW.

Judge NG when the ECM neutral terminal input differs from the reception data from TCM.

2. ENABLE CONDITION

Secondary Parameters	Enable Conditions
Ignition switch	ON
Battery voltage	$\geq 10.9 \text{ V}$
After starting the engine	2 seconds or more
Starter switch	OFF

3. GENERAL DRIVING CYCLE

Perform the diagnosis continuously in 2 seconds or more after starting the engine.

4. DIAGNOSTIC METHOD

Judge NG when the continuous time of completing the malfunction criteria below becomes more than 6.5 seconds. Judge OK and clear NG when the malfunction criteria below are not completed.

Judgment Value

Malfunction Criteria	Threshold Value
Neutral switch signal when park/neutral = "OFF" & any other switches = "ON" on AT	Low (ON)

Time Needed for Diagnosis: 6.5 seconds

Malfunction Indicator Light Illumination: Illuminates when malfunction occurs in 2 continuous driving cycles.

5. DTC CLEAR CONDITION

- When the OK idling cycle was completed 40 times in a row
- When "Clear Memory" was performed

6. MALFUNCTION INDICATOR LIGHT CLEAR CONDITION

- When the OK driving cycle was completed 3 times in a row
- When "Clear Memory" was performed

7. FAIL SAFE

None

8. ECM OPERATION AT DTC SETTING

Memorize the freeze frame data. (For test mode \$02)

Diagnostic Trouble Code (DTC) Detecting Criteria

GENERAL DESCRIPTION

CP:DTC P0851 NEUTRAL SWITCH INPUT CIRCUIT LOW (MT MODEL)

1. OUTLINE OF DIAGNOSIS

Judge the open or short circuit of the neutral SW.

Judge NG when there is no change in the neutral SW even if the driving shift was applied. (There is neutral SW ON/OFF inversion from the vehicle speed and engine speed.)

2. ENABLE CONDITION

Secondary Parameters	Enable Conditions
Ignition switch	ON
Battery voltage	$\geq 10.9 \text{ V}$
After starting the engine	2 seconds or more
Starter switch	OFF

3. GENERAL DRIVING CYCLE

Perform the diagnosis continuously in 2 seconds or more after starting the engine.

4. DIAGNOSTIC METHOD

Judge NG when the malfunction criteria below are completed 3 time or more after the neutral SW change. And clear NG if there is change in the neutral SW.

Judgment Value

Malfunction Criteria	Threshold Value
Neutral switch signal (while changing from a to b below)	Low continues
Driving condition change	a) to b)
a) Vehicle speed = 0 km/h (0 MPH) & engine speed 600 — 900 rpm	
b) Vehicle speed $\geq 64 \text{ km/h}$ (40 MPH) & engine speed 1,600 — 2,550 rpm	

Time Needed for Diagnosis: 3 monitoring

Malfunction Indicator Light Illumination: Illuminates when malfunction occurs in 2 continuous driving cycles.

5. DTC CLEAR CONDITION

- When the OK idling cycle was completed 40 times in a row
- When "Clear Memory" was performed

6. MALFUNCTION INDICATOR LIGHT CLEAR CONDITION

- When the OK driving cycle was completed 3 times in a row
- When "Clear Memory" was performed

7. FAIL SAFE

Cruise control: Not allowed to command cruise control.

8. ECM OPERATION AT DTC SETTING

Memorize the freeze frame data. (For test mode \$02)

Diagnostic Trouble Code (DTC) Detecting Criteria

GENERAL DESCRIPTION

CQ:DTC P0852 NEUTRAL SWITCH INPUT CIRCUIT HIGH (AT MODEL)

1. OUTLINE OF DIAGNOSIS

Detect the open or short circuit of the neutral SW.

Judge NG when the ECM neutral terminal input differs from the reception data from TCM.

2. ENABLE CONDITION

Secondary Parameters	Enable Conditions
Ignition switch	ON
Battery voltage	$\geq 10.9 \text{ V}$
After starting the engine	2 seconds or more
Starter switch	OFF

3. GENERAL DRIVING CYCLE

Perform the diagnosis continuously in 2 seconds or more after starting the engine.

4. DIAGNOSTIC METHOD

Judge NG when the continuous time until completing the malfunction criteria below becomes more than 6.5 seconds. Judge OK and clear NG when the malfunction criteria below are not completed.

Judgment Value

Malfunction Criteria	Threshold Value
Neutral switch signal when park/neutral = "ON" & any other switches = "OFF" on AT	High (OFF)

Time Needed for Diagnosis: 6.5 seconds

Malfunction Indicator Light Illumination: Illuminates when malfunction occurs in 2 continuous driving cycles.

5. DTC CLEAR CONDITION

- When the OK idling cycle was completed 40 times in a row
- When "Clear Memory" was performed

6. MALFUNCTION INDICATOR LIGHT CLEAR CONDITION

- When the OK driving cycle was completed 3 times in a row
- When "Clear Memory" was performed

7. FAIL SAFE

None

8. ECM OPERATION AT DTC SETTING

Memorize the freeze frame data. (For test mode \$02)

Diagnostic Trouble Code (DTC) Detecting Criteria

GENERAL DESCRIPTION

CR:DTC P0852 NEUTRAL SWITCH INPUT CIRCUIT HIGH (MT MODEL)

1. OUTLINE OF DIAGNOSIS

Judge the open or short circuit of the neutral SW.

Judge NG when there is no change in the neutral SW even if the driving shift was applied. (There is neutral SW ON/OFF inversion from the vehicle speed and engine speed.)

2. ENABLE CONDITION

Secondary Parameters	Enable Conditions
Ignition switch	ON
Battery voltage	$\geq 10.9 \text{ V}$
After starting the engine	2 seconds or more
Starter switch	OFF

3. GENERAL DRIVING CYCLE

Perform the diagnosis continuously in 2 seconds or more after starting the engine.

4. DIAGNOSTIC METHOD

Judge NG when the malfunction criteria below are completed 3 time or more after the neutral SW change. And clear NG if there is change in the neutral SW.

Judgment Value

Malfunction Criteria	Threshold Value
Neutral switch signal (while changing from a to b below)	High continues
Driving condition change	a) to b)
a) Vehicle speed = 0 km/h (0 MPH) & engine speed 600 — 900 rpm	
b) Vehicle speed $\geq 64 \text{ km/h}$ (39.8 MPH) & engine speed 1,600 — 2,550 rpm	

Time Needed for Diagnosis: 3 monitoring

Malfunction Indicator Light Illumination: Illuminates when malfunction occurs in 2 continuous driving cycles.

5. DTC CLEAR CONDITION

- When the OK idling cycle was completed 40 times in a row
- When "Clear Memory" was performed

6. MALFUNCTION INDICATOR LIGHT CLEAR CONDITION

- When the OK driving cycle was completed 3 times in a row
- When "Clear Memory" was performed

7. FAIL SAFE

None

8. ECM OPERATION AT DTC SETTING

Memorize the freeze frame data. (For test mode \$02)

Diagnostic Trouble Code (DTC) Detecting Criteria

GENERAL DESCRIPTION

CS:DTC P1152 O₂ SENSOR CIRCUIT RANGE/PERFORMANCE (LOW) (BANK1 SENSOR1)

1. OUTLINE OF DIAGNOSIS

Detect that lambda value remains Low.

Judge NG when lambda value is abnormal in accordance with lambda value of front oxygen (A/F) sensor and running condition that is vehicle speed, amount of intake air engine coolant temperature, sub feedback control, etc.

Lambda value = Actual air fuel ratio/Theoretical air fuel ratio

Lambda > 1: Lean

Lambda < 1: Rich

2. COMPONENT DESCRIPTION

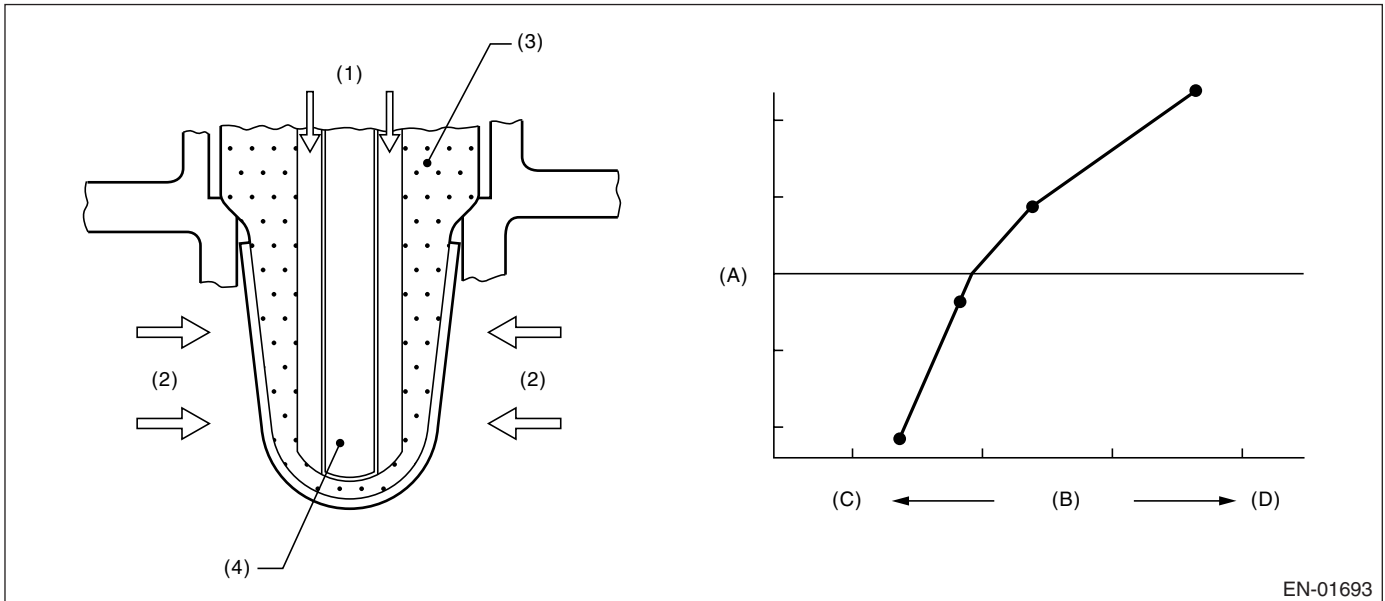

- (1) Atmosphere
- (2) Exhaust
- (3) ZrO₂
- (4) Ceramic heater

- (A) Electromotive force
- (B) Air fuel ratio
- (C) Lean
- (D) Rich

EN-01693

Diagnostic Trouble Code (DTC) Detecting Criteria

GENERAL DESCRIPTION

3. ENABLE CONDITION

Secondary Parameters	Enable Conditions
All secondary parameters to be in enable conditions	4 seconds or more
Battery voltage	> 10.9 V
Atmospheric pressure	> 75.0 kPa (563 mmHg, 22.2 inHg)
Rear oxygen sensor sub feedback	Operating
Rear oxygen sensor output voltage – feedback target voltage	–0.2 V ↔ 0.1 V
or rear oxygen sensor sub feedback compensation coefficient	On Min.
or rear oxygen sensor sub feedback compensation coefficient	On Max.
After engine starting	60 seconds or more
Engine coolant temperature	≥ 70°C (158°F)
Vehicle speed	≥ 20 km/h (12 MPH)
Amount of intake air	≥ 6 g/s
Load change during 0.5 engine rev.	≤ 0.01 g/rev
Impedance of front oxygen (A/F) sensor	0 ↔ 50 Ω
Learning value of evaporation gas density	≤ 0.2
Accumulated time of operating canister purge	20 seconds or more

4. GENERAL DRIVING CYCLE

Perform diagnosis continuously at a constant speed of 20 km/h (12 MPH) or more since 60 seconds after starting the engine.

5. DIAGNOSTIC METHOD

Judge NG when the continuous time of completing the malfunction criteria below becomes more than the time needed for diagnosis (10 seconds). Judge OK and clear NG when the malfunction criteria below are not completed.

Judgment Value

Malfunction Criteria	Threshold Value
Output lambda when rear oxygen sensor sub feedback compensation coefficient being at not high limit	≤ 0.85

Time Needed for Diagnosis: 10 seconds

Malfunction Indicator Light Illumination: Illuminates when malfunction occurs in 2 continuous driving cycles.

6. DTC CLEAR CONDITION

- When the OK idling cycle was completed 40 times in a row
- When “Clear Memory” was performed

7. MALFUNCTION INDICATOR LIGHT CLEAR CONDITION

- When the OK driving cycle was completed 3 times in a row
- When “Clear Memory” was performed

8. FAIL SAFE

- Front oxygen (A/F) sensor main learning correction: Not allowed to calculate
- Correction when re-starting at high temperature: Normally minimum value 0.3 → 0
- Purge control: Not allowed to purge

Diagnostic Trouble Code (DTC) Detecting Criteria

GENERAL DESCRIPTION

9. ECM OPERATION AT DTC SETTING

Memorize the freeze frame data. (For test mode \$02)

CT:DTC P1153 O₂ SENSOR CIRCUIT RANGE/PERFORMANCE (HIGH) (BANK1 SENSOR1)

1. OUTLINE OF DIAGNOSIS

Detect that lambda value remains High.

Judge NG when lambda value is abnormal in accordance with lambda value of front oxygen (A/F) sensor and running condition that is vehicle speed, amount of intake air engine coolant temperature, sub feedback control, etc.

Lambda value = Actual air fuel ratio/Theoretical air fuel ratio

Lambda > 1: Lean

Lambda < 1: Rich

2. COMPONENT DESCRIPTION

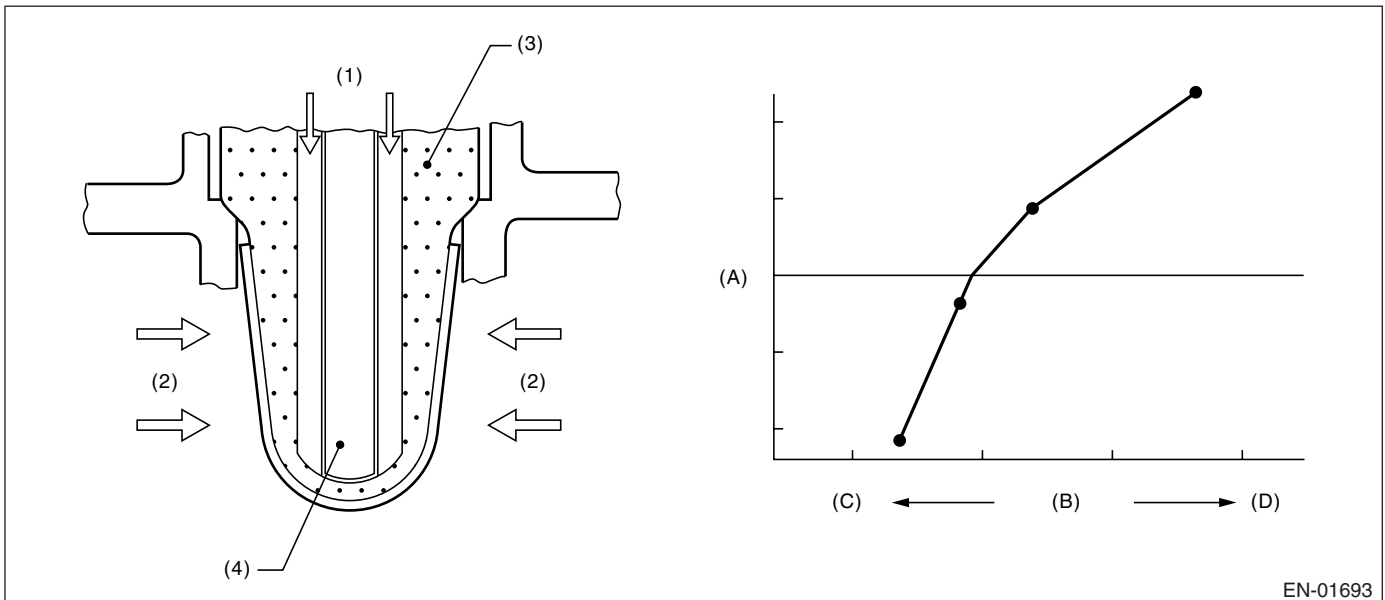

- (1) Atmosphere
- (2) Exhaust
- (3) ZrO₂
- (4) Ceramic heater

- (A) Electromotive force
- (B) Air fuel ratio
- (C) Lean
- (D) Rich

EN-01693

Diagnostic Trouble Code (DTC) Detecting Criteria

GENERAL DESCRIPTION

3. ENABLE CONDITION

Secondary Parameters	Enable Conditions
All secondary parameters to be in enable conditions	4 seconds or more
Battery voltage	> 10.9 V
Atmospheric pressure	> 75.0 kPa (563 mmHg, 22.2 inHg)
Rear oxygen sensor sub feedback	Operating
Rear oxygen sensor output voltage – feedback target voltage	–0.2 V ↔ 0.1 V
or rear oxygen sensor sub feedback compensation coefficient	On Min.
or rear oxygen sensor sub feedback compensation coefficient	On Max.
After engine starting	60 seconds or more
Engine coolant temperature	≥ 70°C (158°F)
Vehicle speed	≥ 20 km/h (12 MPH)
Amount of intake air	≥ 6 g/s
Load change during 0.5 engine rev.	≤ 0.02 g/rev
Impedance of front oxygen (A/F) sensor	0 ↔ 50 Ω
Learning value of evaporation gas density	≤ 0.2
Accumulated time of operating canister purge	20 seconds or more

4. GENERAL DRIVING CYCLE

Perform diagnosis continuously at a constant speed of 20 km/h (12 MPH) or more since 60 seconds after starting the engine.

5. DIAGNOSTIC METHOD

Judge NG when the continuous time of completing the malfunction criteria below becomes more than the time needed for diagnosis (10 seconds). Judge OK and clear NG when the malfunction criteria below are not completed.

Judgment Value

Malfunction Criteria	Threshold Value
Output lambda when rear O ₂ sensor sub feedback compensation coefficient value being at not low limit	≥ 1.15

Time Needed for Diagnosis: 10 seconds

Malfunction Indicator Light Illumination: Illuminates when malfunction occurs in 2 continuous driving cycles.

6. DTC CLEAR CONDITION

- When the OK idling cycle was completed 40 times in a row
- When “Clear Memory” was performed

7. MALFUNCTION INDICATOR LIGHT CLEAR CONDITION

- When the OK driving cycle was completed 3 times in a row
- When “Clear Memory” was performed

8. FAIL SAFE

- Front oxygen (A/F) sensor main learning correction: Not allowed to calculate
- Correction when re-starting at high temperature: Normally minimum value 0.3 → 0
- Purge control: Not allowed to purge

Diagnostic Trouble Code (DTC) Detecting Criteria

GENERAL DESCRIPTION

9. ECM OPERATION AT DTC SETTING

Memorize the freeze frame data. (For test mode \$02)

CU:DTC P1160 RETURN SPRING FAILURE

1. OUTLINE OF DIAGNOSIS

Judge NG when the valve does not move to the close direction with the motor power stopped and the valve open more than the default opening.

2. COMPONENT DESCRIPTION

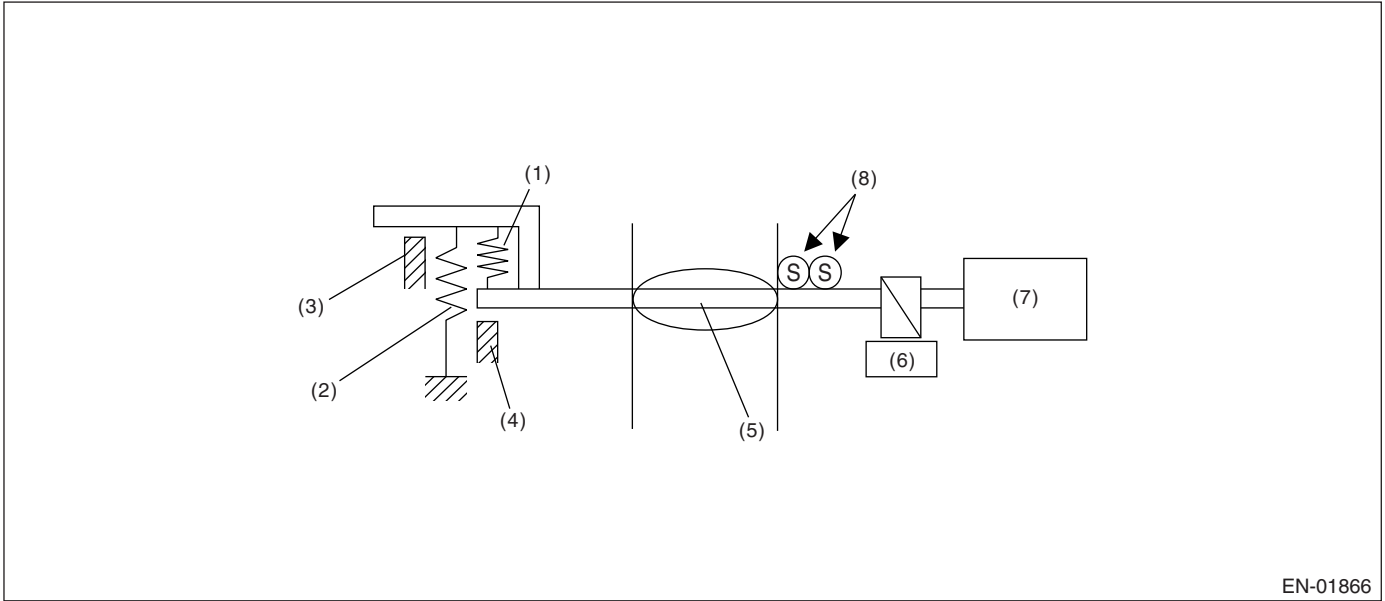

- | | | |
|--------------------------|-------------------------|----------------------------------|
| (1) Opener spring | (4) Full closed stopper | (7) DC motor |
| (2) Return spring | (5) Throttle valve | (8) Main and sub throttle sensor |
| (3) Intermediate stopper | (6) Gear | |

3. ENABLE CONDITION

Secondary Parameters	Enable Conditions
Throttle opening angle	OFF
Motor continuity	OFF

4. GENERAL DRIVING CYCLE

- Ignition switch ON → OFF
- Ignition switch OFF → ON (After clear memory only)

5. DIAGNOSTIC METHOD

• Abnormality Judgment

Judge NG when the continuous time of completing the malfunction criteria below becomes more than 0.6 seconds.

Judgment Value

Malfunction Criteria	Threshold Value
Opening variation after continuity is set to OFF	< 2°

Time Needed for Diagnosis: 600 milliseconds

Malfunction Indicator Light Illumination: Illuminates as soon as malfunction occurs.

Diagnostic Trouble Code (DTC) Detecting Criteria

GENERAL DESCRIPTION

6. DTC CLEAR CONDITION

- When the OK idling cycle was completed 40 times in a row
- When "Clear Memory" was performed (Only with engine stopped)

7. MALFUNCTION INDICATOR LIGHT CLEAR CONDITION

- When the OK driving cycle was completed 3 times in a row
- When "Clear Memory" was performed (Only with engine stopped)

8. FAIL SAFE

Fix the throttle opening to 6°.

9. ECM OPERATION AT DTC SETTING

Memorize the freeze frame data. (For test mode \$02)

Diagnostic Trouble Code (DTC) Detecting Criteria

GENERAL DESCRIPTION

CV:DTC P1400 FUEL TANK PRESSURE CONTROL SOLENOID VALVE CIRCUIT LOW

1. OUTLINE OF DIAGNOSIS

Detect open or short circuit of pressure control solenoid valve. Judge NG when ECM output level is different from actual terminal level.

2. COMPONENT DESCRIPTION

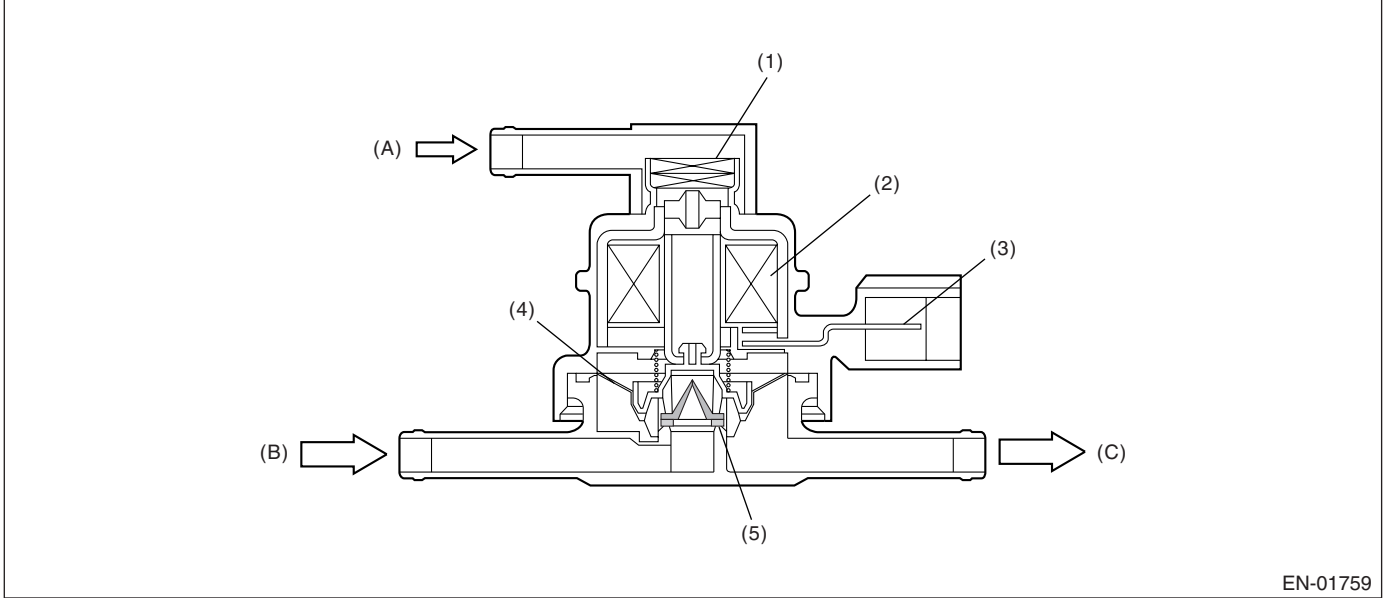

- | | |
|------------------------|--------------------------|
| (1) Filter | (A) Atmospheric pressure |
| (2) Coil | (B) Shut off valve |
| (3) Connector terminal | (C) To fuel tank |
| (4) Diaphragm | |
| (5) Valve | |

3. ENABLE CONDITION

Secondary Parameters	Enable Conditions
Ignition switch	ON
Battery voltage	$\geq 10.9 \text{ V}$
After engine starting	1 second or more

4. GENERAL DRIVING CYCLE

Always perform the diagnosis after starting the engine.

5. DIAGNOSTIC METHOD

Judge NG when the continuous time of completing the malfunction criteria below becomes more than time needed for diagnosis (2.5 seconds). Judge OK and clear the NG when the malfunction criteria below are not completed.

Judgment Value

Malfunction Criteria	Threshold Value
Terminal voltage when ECM outputs off signal	Low

Time Needed for Diagnosis: 2.5 seconds

Malfunction Indicator Light Illumination: Illuminates when malfunction occurs in two continuous drive cycles.

Diagnostic Trouble Code (DTC) Detecting Criteria

GENERAL DESCRIPTION

6. DTC CLEAR CONDITION

- When the OK idling cycle was completed 40 times in a row
- When "Clear Memory" was performed

7. MALFUNCTION INDICATOR LIGHT CLEAR CONDITION

- When the OK driving cycle was completed 3 times in a row
- When "Clear Memory" was performed

8. FAIL SAFE

None

9. ECM OPERATION AT DTC SETTING

Memorize the freeze frame data. (For test mode \$02)

Diagnostic Trouble Code (DTC) Detecting Criteria

GENERAL DESCRIPTION

CW:DTC P1410 SECONDARY AIR INJECTION SYSTEM SWITCHING VALVE STUCK OPEN

1. OUTLINE OF DIAGNOSIS

Always detect the open malfunction of both electromagnetic valve and reed valve of combi valve. Calculate maximum and minimum values of secondary air supply pipe pressure sensor output voltage during certain period of time after engine starting, and cumulative deviation of output voltage. Judge NG when the difference between max. and min. values, and cumulative deviation are large.

2. ENABLE CONDITION

Secondary Parameters	Enable Conditions
Engine speed	< 500 rpm
After engine starting	9 seconds or more
After secondary air injection system is stopped	9 seconds or more
Intake air amount	2 g (0.07 oz)/sec. or more and less than 400 g (14.11 oz)/sec.
Battery voltage	≥ 10.9 V

3. GENERAL DRIVING CYCLE

Perform the diagnosis continuously when amount of air flow is large while secondary air pump is not operated after engine starting.

4. DIAGNOSTIC METHOD

Pulsation occurs in secondary air supply pipe pressure sensor output when both electromagnetic valve and reed valve of combi valve have open malfunction. Find this pulsation in the following method, and detect the malfunction.

Calculate maximum (max) and minimum (min) values of secondary air supply pipe pressure sensor output voltage, and cumulative deviation (sum) of output voltage during kCOTIM sec. Compare the difference value between maximum and minimum values with threshold value, and also cumulative value with threshold value. Count up the number of times when both values exceed threshold value. Judge NG when the number of times becomes kCOCOT. Judge OK when both of values do not exceed threshold value or only one of them does.

Judgment Value

Malfunction Criteria	Threshold Value
Difference value between maximum and minimum values of internal pressure in pipe	≥ 0.048 V
Cumulative variation value of internal pressure in pipe at every 4 milliseconds	≥ 24 V
Variation value in ambient pressure	< 4 mmHg

Time Needed for Diagnosis: 10 seconds × 2 times

Malfunction Indicator Light Illumination: Illuminates when malfunction occurs.

5. DTC CLEAR CONDITION

- When the OK idling cycle was completed 40 times in a row
- When "Clear Memory" was performed

6. MALFUNCTION INDICATOR LIGHT CLEAR CONDITION

- When the OK driving cycle was completed 3 times in a row
- When "Clear Memory" was performed

7. FAIL SAFE

None

Diagnostic Trouble Code (DTC) Detecting Criteria

GENERAL DESCRIPTION

8. ECM OPERATION AT DTC SETTING

Memorize the freeze frame data. (For test mode \$02)

CX:DTC P1418 SECONDARY AIR INJECTION SYSTEM CONTROL "A" CIRCUIT SHORTED

1. OUTLINE OF DIAGNOSIS

Judge NG when the ECM output level is different from the actual terminal level.

2. ENABLE CONDITION

Secondary Parameters	Enable Conditions
OFF	

3. GENERAL DRIVING CYCLE

Always perform the diagnosis continuously.

4. DIAGNOSTIC METHOD

• Abnormality Judgment

Judge NG when the continuous time of completing the malfunction criteria below becomes more than the time needed for diagnosis (2.5 seconds).

Judgment Value

Malfunction Criteria	Threshold Value
Battery voltage	≥ 10.9 V
Ignition	ON
Terminal voltage when ECM transmits ON signal	High

Time Needed for Diagnosis: 2.5 seconds

Malfunction Indicator Light Illumination: Illuminates when malfunction occurs.

• Normality Judgment

Judge OK and clear the NG when the malfunction criteria below are completed.

Judgment Value

Malfunction Criteria	Threshold Value
Battery voltage	≥ 10.9 V
Ignition	ON
Terminal voltage when ECM transmits ON signal	Low

5. DTC CLEAR CONDITION

- When the OK idling cycle was completed 40 times in a row
- When "Clear Memory" was performed

6. MALFUNCTION INDICATOR LIGHT CLEAR CONDITION

- When the OK driving cycle was completed 3 times in a row
- When "Clear Memory" was performed

7. FAIL SAFE

None

8. ECM OPERATION AT DTC SETTING

Memorize the freeze frame data. (For test mode \$02)

Diagnostic Trouble Code (DTC) Detecting Criteria

GENERAL DESCRIPTION

CY:DTC P1420 FUEL TANK PRESSURE CONTROL SOL. VALVE CIRCUIT HIGH

1. OUTLINE OF DIAGNOSIS

Detect open or short circuit of pressure control solenoid valve.
Judge NG when ECM output level is different from actual terminal level.

2. COMPONENT DESCRIPTION

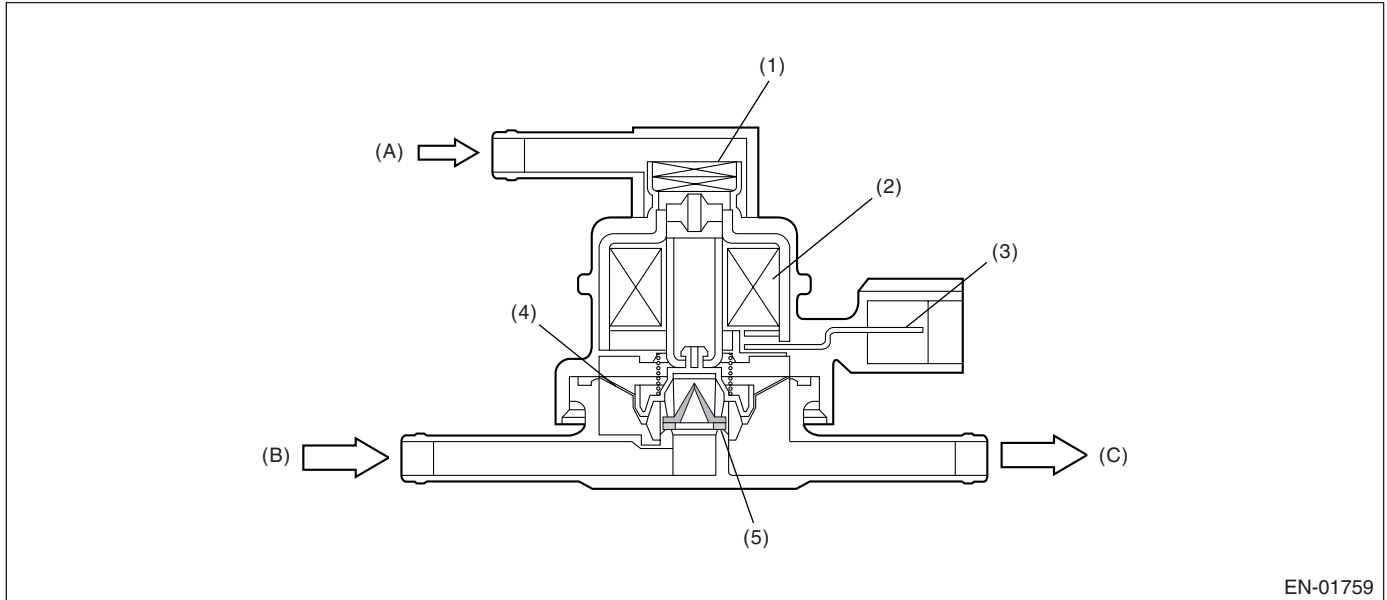

- | | |
|------------------------|--------------------------|
| (1) Filter | (A) Atmospheric pressure |
| (2) Coil | (B) Shut off valve |
| (3) Connector terminal | (C) To fuel tank |
| (4) Diaphragm | |
| (5) Valve | |

3. ENABLE CONDITION

Secondary Parameters	Enable Conditions
Ignition switch	ON
Battery voltage	$\geq 10.9 \text{ V}$
After engine starting	1 second or more

4. GENERAL DRIVING CYCLE

Always perform the diagnosis after starting the engine.

5. DIAGNOSTIC METHOD

Judge NG when the continuous time of completing the malfunction criteria below becomes more than time needed for diagnosis (2.5 seconds). Judge OK and clear the NG when the malfunction criteria below are not completed.

Judgment Value

Malfunction Criteria	Threshold Value
Terminal voltage when ECM outputs off signal	High

Time Needed for Diagnosis: 2.5 seconds

Malfunction Indicator Light Illumination: Illuminates when malfunction occurs in two continuous drive cycles.

Diagnostic Trouble Code (DTC) Detecting Criteria

GENERAL DESCRIPTION

6. DTC CLEAR CONDITION

- When the OK idling cycle was completed 40 times in a row
- When "Clear Memory" was performed

7. MALFUNCTION INDICATOR LIGHT CLEAR CONDITION

- When the OK driving cycle was completed 3 times in a row
- When "Clear Memory" was performed

8. FAIL SAFE

None

9. ECM OPERATION AT DTC SETTING

Memorize the freeze frame data. (For test mode \$02)

Diagnostic Trouble Code (DTC) Detecting Criteria

GENERAL DESCRIPTION

CZ:DTC P1443 VENT CONTROL SOLENOID VALVE FUNCTION PROBLEM

1. OUTLINE OF DIAGNOSIS

Detect the drain valve function abnormality.
Judge NG when the fuel tank pressure is small.

2. COMPONENT DESCRIPTION

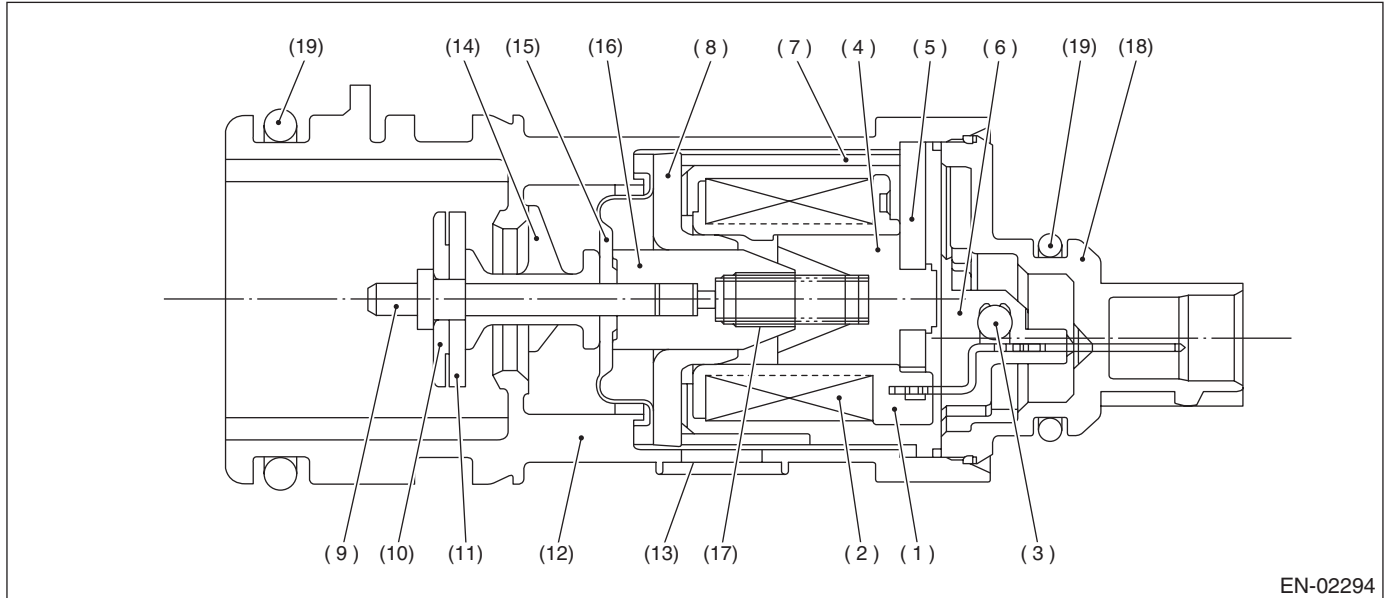

- | | |
|--------------------|-------------------|
| (1) Bobbin | (11) Valve |
| (2) Coil | (12) Housing |
| (3) Diode | (13) Filter |
| (4) Stator core | (14) Retainer |
| (5) End plate | (15) Diaphragm |
| (6) Body | (16) Movable core |
| (7) Yoke | (17) Spring |
| (8) Magnetic plate | (18) Cover |
| (9) Shaft | (19) O-ring |
| (10) Plate | |

3. ENABLE CONDITION

Secondary Parameter	Enable Condition
Drain valve	Open
Battery voltage	≥ 10.9 V
Atmospheric pressure	≥ 75.0 kPa (563 mmHg, 22.17 inHg)
Tank pressure when starter ON → OFF	$-0.67 \leftrightarrow 1.43$ kPa ($-5 \leftrightarrow 10.7$ mmHg, $-0.20 \leftrightarrow 0.42$ inHg)

4. GENERAL DRIVING CYCLE

Always perform the diagnosis continuously.

Diagnostic Trouble Code (DTC) Detecting Criteria

GENERAL DESCRIPTION

5. DIAGNOSTIC METHOD

• Abnormality Judgment

Judge NG when the continuous time of completing the malfunction criteria below becomes more than 3 seconds.

Judgment Value

Malfunction Criteria	Threshold Value
Tank pressure	≤ -4.0 kPa (-30 mmHg, -1.18 inHg)

Time Needed for Diagnosis: 3 seconds

Malfunction Indicator Light Illumination: Illuminates as soon as the malfunction occurs.

• Normality Judgment

Judge OK and clear the NG when the malfunction criteria below are completed.

Judgment Value

Malfunction Criteria	Threshold Value
Tank pressure	> -4.0 kPa (-30 mmHg, -1.18 inHg)
Cumulative time when the malfunction criteria below are completed	≥ 30 seconds
Duty ratio of purge control solenoid valve	Except 0
Fuel temperature	$-10 \leftrightarrow 45^\circ\text{C}$ ($14 \leftrightarrow 113^\circ\text{F}$)
Relative ratio of intake manifold	≤ -26.7 kPa (-200 mmHg, -7.87 inHg)

6. DTC CLEAR CONDITION

- When the OK idling cycle was completed 40 times in a row
- When "Clear Memory" was performed

7. MALFUNCTION INDICATOR LIGHT CLEAR CONDITION

- When the OK driving cycle was completed 3 times in a row
- When "Clear Memory" was performed

8. FAIL SAFE

PCV control: Open the PCV solenoid.

9. ECM OPERATION AT DTC SETTING

Memorize the freeze frame data. (For test mode \$02)

Diagnostic Trouble Code (DTC) Detecting Criteria

GENERAL DESCRIPTION

DA:DTC P1491 POSITIVE CRANKCASE VENTILATION (BLOW-BY) FUNCTION PROBLEM

1. OUTLINE OF DIAGNOSIS

Detect the blow-by hose release abnormality.
Judge NG when the diagnosis terminal voltage is high.

2. COMPONENT DESCRIPTION

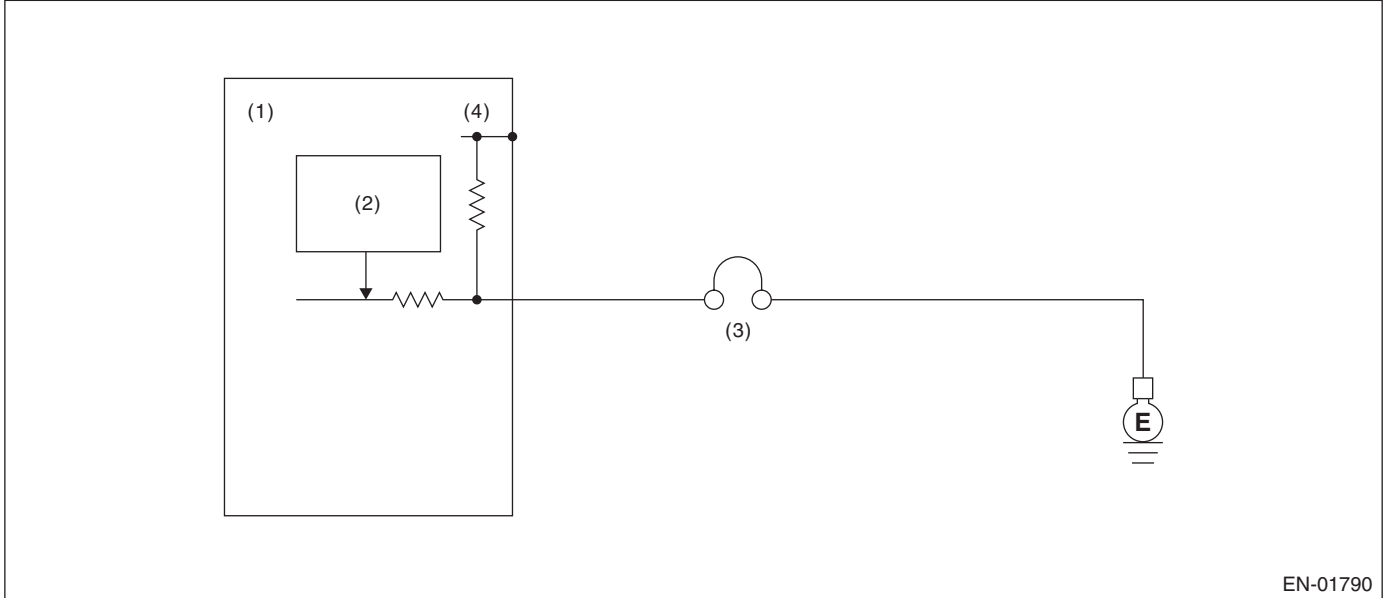

- (1) Engine control module (ECM)
- (2) Detecting circuit
- (3) PCV diagnosis connector
- (4) 5 V

3. ENABLE CONDITION

Secondary Parameter	Enable Condition
None	

4. GENERAL DRIVING CYCLE

Always perform the diagnosis continuously.

5. DIAGNOSIS METHOD

• Abnormality Judgment

Judge NG when the continuous time until completing the malfunction criteria below becomes more than 2.5 second.

Judgment Value

Malfunction Criteria	Threshold Value
Battery voltage	> 10.9 V
Positive crankcase ventilation diagnosis terminal voltage	High
Engine speed	≥ 500 rpm

Time Needed for Diagnosis: 2.5 second

Malfunction Indicator Light Illumination: Illuminates as soon as malfunction occurs.

Diagnostic Trouble Code (DTC) Detecting Criteria

GENERAL DESCRIPTION

• Normality Judgment

Judge OK and clear NG when the malfunction criteria below is completed.

Judgment Value

Malfunction Criteria	Threshold Value
Battery voltage	> 10.9 V
Positive crankcase ventilation diagnosis terminal voltage	Low
Engine speed	≥ 500 rpm

6. DTC CLEAR CONDITION

- When the OK idling cycle was completed 40 times in a row
- When "Clear Memory" was performed

7. MALFUNCTION INDICATOR LIGHT CLEAR CONDITION

- When the OK driving cycle was performed 3 times in a row
- When "Clear Memory" was performed

8. FAIL SAFE

None

9. ECM OPERATION AT DTC SETTING

Memorize the diagnosis value and trouble standard value. (For test mode \$06)

Diagnostic Trouble Code (DTC) Detecting Criteria

GENERAL DESCRIPTION

DB:DTC P1518 STARTER SWITCH CIRCUIT LOW INPUT

1. OUTLINE OF DIAGNOSIS

Detect the open or short circuit of starter SW.

Judge OFF NG when the engine starts without starter SW signal.

2. ENABLE CONDITION

Secondary Parameters	Enable Conditions
None	

3. GENERAL DRIVING CYCLE

Always perform the diagnosis continuously.

4. DIAGNOSTIC METHOD

• Abnormality Judgment

Judge OFF NG when the malfunction criteria below are completed.

Judgment Value

Malfunction Criteria	Threshold Value
Vehicle speed	< 1 km/h (0.62 MPH)
Starter ON signal	Not detected
Engine speed after completing 0.8 seconds or more of engine speed less than 500 rpm	≥ 500 rpm

Time Needed for Diagnosis: 1 second

Malfunction Indicator Light Illumination: Illuminates when malfunction occurs in 2 continuous driving cycles.

• Normality Judgment

Judge OFF OK and clear the NG when the malfunction criteria below are completed.

Judgment Value

Malfunction Criteria	Threshold Value
Starter ON	Experienced
Starter ON diagnosis	Not experienced
Battery voltage	> 8 V

5. DTC CLEAR CONDITION

- When the OK idling cycle was completed 40 times in a row
- When "Clear Memory" was performed

6. MALFUNCTION INDICATOR LIGHT CLEAR CONDITION

- When the OK driving cycle was completed 3 times in a row
- When "Clear Memory" was performed

7. FAIL SAFE

None

8. ECM OPERATION AT DTC SETTING

Memorize the freeze frame data. (For test mode \$02)

Diagnostic Trouble Code (DTC) Detecting Criteria

GENERAL DESCRIPTION

DC:DTC P1560 BACK-UP VOLTAGE CIRCUIT MALFUNCTION

1. OUTLINE OF DIAGNOSIS

Detect open or short circuit of the back-up voltage circuit.

Judge NG when the back-up voltage becomes smaller than the battery voltage.

2. ENABLE CONDITION

Secondary Parameter	Enable Condition
None	

3. GENERAL DRIVING CYCLE

Always perform the diagnosis continuously.

4. DIAGNOSTIC METHOD

• Abnormality Judgment

Judge NG when the continuous time of completing the malfunction criteria below becomes more than 2.5 seconds.

Judgment Value

Malfunction Criteria	Threshold Value
Voltage of back-up power	< Battery voltage × 0.7
Battery voltage	≥ 10.9 V

Time Needed for Diagnosis: 2.5 seconds

Malfunction Indicator Light Illumination: Illuminates as soon as malfunction occurs.

• Normality Judgment

Judge OK and clear NG when the malfunction criteria below is completed.

Judgment Value

Malfunction Criteria	Threshold Value
Voltage of back-up power supply	≥ Battery voltage × 0.7
Battery voltage	≥ 10.9 V

5. DTC CLEAR CONDITION

- When the OK idling cycle was completed 40 times in a row
- When "Clear Memory" was performed

6. MALFUNCTION INDICATOR LIGHT CLEAR CONDITION

- When the OK driving cycle was completed 3 times in a row
- When "Clear Memory" was performed

7. FAIL SAFE

None

8. ECM OPERATION AT DTC SETTING

Memorize the freeze frame data. (For test mode \$02)

Diagnostic Trouble Code (DTC) Detecting Criteria

GENERAL DESCRIPTION

DD:DTC P1570 ANTENNA

1. OUTLINE OF DIAGNOSIS

For the detecting criteria, refer to P0513.

<Ref. to GD(H4DOTC)-170, DTC P0513 INCORRECT IMMOBILIZER KEY, Diagnostic Trouble Code (DTC) Detecting Criteria.>

DE:DTC P1571 REFERENCE CODE INCOMPATIBILITY

1. OUTLINE OF DIAGNOSIS

For the detecting criteria, refer to P0513.

<Ref. to GD(H4DOTC)-170, DTC P0513 INCORRECT IMMOBILIZER KEY, Diagnostic Trouble Code (DTC) Detecting Criteria.>

DF:DTC P1572 IMM CIRCUIT FAILURE (EXCEPT ANTENNA CIRCUIT)

1. OUTLINE OF DIAGNOSIS

For the detecting criteria, refer to P0513.

<Ref. to GD(H4DOTC)-170, DTC P0513 INCORRECT IMMOBILIZER KEY, Diagnostic Trouble Code (DTC) Detecting Criteria.>

DG:DTC P1574 KEY COMMUNICATION FAILURE

1. OUTLINE OF DIAGNOSIS

For the detecting criteria, refer to P0513.

<Ref. to GD(H4DOTC)-170, DTC P0513 INCORRECT IMMOBILIZER KEY, Diagnostic Trouble Code (DTC) Detecting Criteria.>

DH:DTC P1576 EGI CONTROL MODULE EEPROM

1. OUTLINE OF DIAGNOSIS

For the detecting criteria, refer to P0513.

<Ref. to GD(H4DOTC)-170, DTC P0513 INCORRECT IMMOBILIZER KEY, Diagnostic Trouble Code (DTC) Detecting Criteria.>

DI: DTC P1577 IMM CONTROL MODULE EEPROM

1. OUTLINE OF DIAGNOSIS

For the detecting criteria, refer to P0513.

<Ref. to GD(H4DOTC)-170, DTC P0513 INCORRECT IMMOBILIZER KEY, Diagnostic Trouble Code (DTC) Detecting Criteria.>

Diagnostic Trouble Code (DTC) Detecting Criteria

GENERAL DESCRIPTION

DJ:DTC P2004 INTAKE MANIFOLD RUNNER CONTROL STUCK OPEN (BANK 1)

1. OUTLINE OF DIAGNOSIS

Detect the malfunction of tumble generator valve motor function.

Judge open fixing malfunction when the opening degree is large even after finishing the tumble generator valve open driving.

2. ENABLE CONDITION

Secondary Parameters	Enable Conditions
Battery voltage	≥ 10.9 V
Engine coolant temperature	$\geq 0^{\circ}\text{C}$ (32°F)
Ambient temperature	$\geq 0^{\circ}\text{C}$ (32°F)

3. GENERAL DRIVING CYCLE

Always perform the diagnosis continuously.

4. DIAGNOSTIC METHOD

• Abnormality Judgment

Judge NG when the continuous time of completing the malfunction criteria below becomes more than 3 seconds.

Judgment Value

Malfunction Criteria	Threshold Value
Tumble generator valve angle	$\geq 67.4^{\circ}$
Tumble generator valve "close" signal output	2.2 seconds or more

Time Needed for Diagnosis: 3 seconds

Malfunction Indicator Light Illumination: Illuminates as soon as malfunction occurs.

• Normality Judgment

Judge OK and clear the NG when the malfunction criteria below are completed.

Judgment Value

Malfunction Criteria	Threshold Value
Tumble generator valve angle	$< 67.4^{\circ}$
Tumble generator valve "close" signal output	2.2 seconds or more

5. DTC CLEAR CONDITION

- When the OK idling cycle was completed 40 times in a row
- When "Clear Memory" was performed

6. MALFUNCTION INDICATOR LIGHT CLEAR CONDITION

- When the OK driving cycle was completed 3 times in a row
- When "Clear Memory" was performed

7. FAIL SAFE

Tumble generator valve opening

- For tumble generator valve all closing points learning, not allowed to update to the closing side.
- For tumble generator valve all opening points learning, not allowed to update to the opening side.

Tumble generator valve control

- Output the open signal.

8. ECM OPERATION AT DTC SETTING

Memorize the freeze frame data. (For test mode \$02)

Diagnostic Trouble Code (DTC) Detecting Criteria

GENERAL DESCRIPTION

DK:DTC P2005 INTAKE MANIFOLD RUNNER CONTROL STUCK OPEN (BANK 2)

1. OUTLINE OF DIAGNOSIS

Detect the malfunction of tumble generator valve motor function.

Judge open fixing malfunction when the opening degree is large even after finishing the tumble generator valve closing driving.

2. ENABLE CONDITION

Secondary Parameters	Enable Conditions
Battery voltage	$\geq 10.9 \text{ V}$
Engine coolant temperature	$\geq 0^\circ\text{C}$ (32°F)
Ambient temperature	$\geq 0^\circ\text{C}$ (32°F)

3. GENERAL DRIVING CYCLE

Always perform the diagnosis continuously.

4. DIAGNOSTIC METHOD

• Abnormality Judgment

Judge NG when the continuous time of completing the malfunction criteria below becomes more than 3 seconds.

Judgment Value

Malfunction Criteria	Threshold Value
Tumble generator valve angle	$\geq 67.4^\circ$
Tumble generator valve "close" signal output	2.2 seconds or more

Time Needed for Diagnosis: 3 seconds

Malfunction Indicator Light Illumination: Illuminates as soon as malfunction occurs.

• Normality Judgment

Judge OK and clear the NG when the malfunction criteria below are completed.

Judgment Value

Malfunction Criteria	Threshold Value
Tumble generator valve angle	$< 67.4^\circ$
Tumble generator valve "close" signal output	2.2 seconds or more

5. DTC CLEAR CONDITION

- When the OK idling cycle was completed 40 times in a row
- When "Clear Memory" was performed

6. MALFUNCTION INDICATOR LIGHT CLEAR CONDITION

- When the OK driving cycle was completed 3 times in a row
- When "Clear Memory" was performed

7. FAIL SAFE

Tumble generator valve opening

- For tumble generator valve all closing points learning, not allowed to update to the closing side.
- For tumble generator valve all opening points learning, not allowed to update to the opening side.

Tumble generator valve control

- Output the open signal.

8. ECM OPERATION AT DTC SETTING

Memorize the freeze frame data. (For test mode \$02)

Diagnostic Trouble Code (DTC) Detecting Criteria

GENERAL DESCRIPTION

DL:DTC P2006 INTAKE MANIFOLD RUNNER CONTROL STUCK CLOSED (BANK 1)

1. OUTLINE OF DIAGNOSIS

Detect the malfunction of tumble generator valve motor function.

Judge close fixing malfunction when the opening degree is small even after finishing the tumble generator valve open driving.

2. ENABLE CONDITION

Secondary Parameters	Enable Conditions
Battery voltage	$\geq 10.9 \text{ V}$
Engine coolant temperature	$\geq 0^\circ\text{C}$ (32°F)
Ambient temperature	$\geq 0^\circ\text{C}$ (32°F)

3. GENERAL DRIVING CYCLE

Always perform the diagnosis continuously.

4. DIAGNOSTIC METHOD

• Abnormality Judgment

Judge NG when the continuous time of completing the malfunction criteria below becomes more than 3 seconds.

Judgment Value

Malfunction Criteria	Threshold Value
Tumble generator valve angle	$< 67.4^\circ$
Tumble generator valve "open" signal output	2.2 seconds or more

Time Needed for Diagnosis: 3 seconds

Malfunction Indicator Light Illumination: Illuminates as soon as malfunction occurs.

• Normality Judgment

Judge OK and clear the NG when the malfunction criteria below are completed.

Judgment Value

Malfunction Criteria	Threshold Value
Tumble generator valve angle	$\geq 67.4^\circ$
Tumble generator valve "open" signal output	2.2 seconds or more

5. DTC CLEAR CONDITION

- When the OK idling cycle was completed 40 times in a row
- When "Clear Memory" was performed

6. MALFUNCTION INDICATOR LIGHT CLEAR CONDITION

- When the OK driving cycle was completed 3 times in a row
- When "Clear Memory" was performed

7. FAIL SAFE

Tumble generator valve opening

- For tumble generator valve all closing points learning, not allowed to update to the closing side.
- For tumble generator valve all opening points learning, not allowed to update to the opening side.

Tumble generator valve control

- Output the close signal.

8. ECM OPERATION AT DTC SETTING

Memorize the freeze frame data. (For test mode \$02)

Diagnostic Trouble Code (DTC) Detecting Criteria

GENERAL DESCRIPTION

DM:DTC P2007 INTAKE MANIFOLD RUNNER CONTROL STUCK CLOSED (BANK 2)

1. OUTLINE OF DIAGNOSIS

Detect the malfunction of tumble generator valve motor function.

Judge close fixing malfunction when the opening degree is small even after finishing the tumble generator valve open driving.

2. ENABLE CONDITION

Secondary Parameters	Enable Conditions
Battery voltage	$\geq 10.9 \text{ V}$
Engine coolant temperature	$\geq 0^\circ\text{C}$ (32°F)
Ambient temperature	$\geq 0^\circ\text{C}$ (32°F)

3. GENERAL DRIVING CYCLE

Always perform the diagnosis continuously.

4. DIAGNOSTIC METHOD

• Abnormality Judgment

Judge NG when the continuous time of completing the malfunction criteria below becomes more than 3 seconds.

Judgment Value

Malfunction Criteria	Threshold Value
Tumble generator valve angle	$< 67.4^\circ$
Tumble generator valve "open" signal output	2.2 seconds or more

Time Needed for Diagnosis: 3 seconds

Malfunction Indicator Light Illumination: Illuminates as soon as malfunction occurs.

• Normality Judgment

Judge OK and clear the NG when the malfunction criteria below are completed.

Judgment Value

Malfunction Criteria	Threshold Value
Tumble generator valve angle	$\geq 67.4^\circ$
Tumble generator valve "open" signal output	2.2 seconds or more

5. DTC CLEAR CONDITION

- When the OK idling cycle was completed 40 times in a row
- When "Clear Memory" was performed

6. MALFUNCTION INDICATOR LIGHT CLEAR CONDITION

- When the OK driving cycle was completed 3 times in a row
- When "Clear Memory" was performed

7. FAIL SAFE

Tumble generator valve opening

- For tumble generator valve all closing points learning, not allowed to update to the closing side.
- For tumble generator valve all opening points learning, not allowed to update to the opening side.

Tumble generator valve control

- Output the close signal.

8. ECM OPERATION AT DTC SETTING

Memorize the freeze frame data. (For test mode \$02)

DN:DTC P2008 INTAKE MANIFOLD RUNNER CONTROL CIRCUIT / OPEN (BANK 1)

1. OUTLINE OF DIAGNOSIS

Detect the open or short circuit of tumble generator valve motor.

Judge NG when the open signal is sent from IC after tumble generator valve driving IC diagnosis.

2. COMPONENT DESCRIPTION

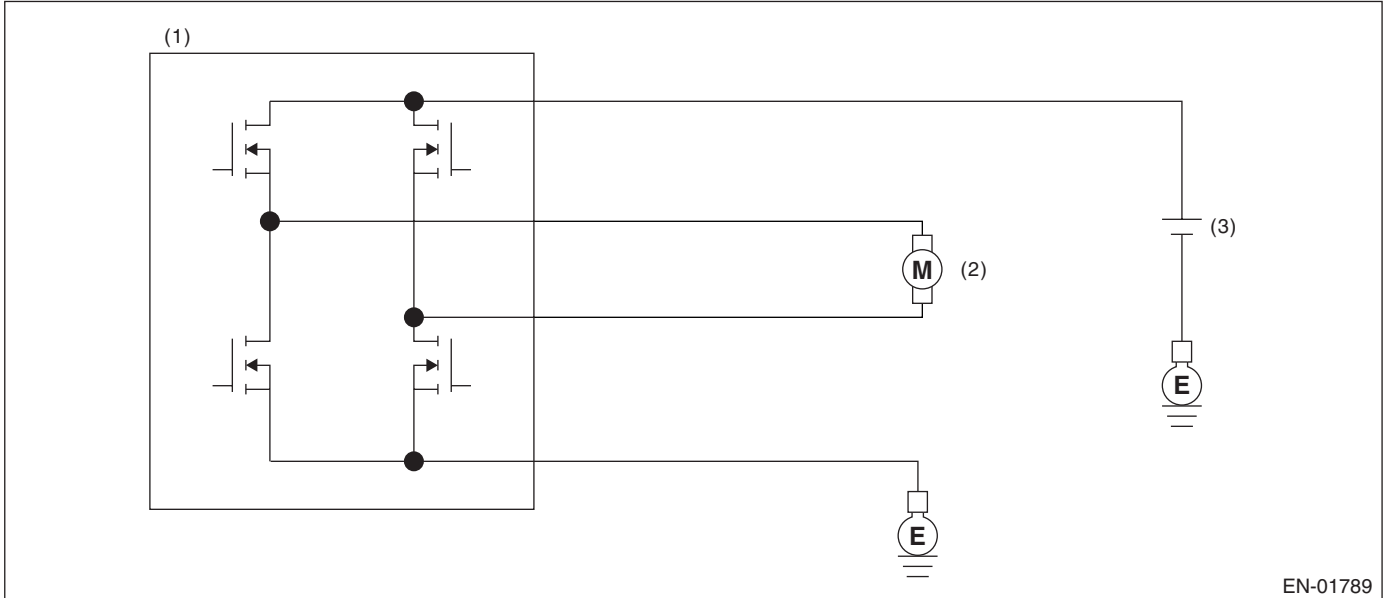

- (1) Engine control module (ECM)
- (2) Tumble generator valve
- (3) Battery

3. ENABLE CONDITION

Secondary Parameters	Enable Conditions
Battery voltage	≥ 10.9 V
ECM output signal	before set ON → OFF
Tumble generator valve ON signal output time	20 milliseconds or more

4. GENERAL DRIVING CYCLE

Always perform the diagnosis continuously.

5. DIAGNOSTIC METHOD

At the main IC, check the sent signal at each timing which occurs just before the tumble generator valve output is set to ON and OFF, and judge open NG when the open NG signal is sent during 1 second in a row. Judge OK and clear the NG when the OK signal is sent.

Judgment Value

Malfunction Criteria	Threshold Value
Open NG signal input	Low
Overcurrent NG signal input	High

Time Needed for Diagnosis: 10 seconds

Malfunction Indicator Light Illumination: Illuminates as soon as malfunction occurs.

Diagnostic Trouble Code (DTC) Detecting Criteria

GENERAL DESCRIPTION

6. DTC CLEAR CONDITION

- When the OK idling cycle was completed 40 times in a row
- When "Clear Memory" was performed

7. MALFUNCTION INDICATOR LIGHT CLEAR CONDITION

- When the OK driving cycle was completed 3 times in a row
- When "Clear Memory" was performed

8. FAIL SAFE

Tumble generator valve control: Not allowed to move tumble generator valve.

9. ECM OPERATION AT DTC SETTING

Memorize the freeze frame data. (For test mode \$02)

Diagnostic Trouble Code (DTC) Detecting Criteria

GENERAL DESCRIPTION

DO:DTC P2009 INTAKE MANIFOLD RUNNER CONTROL CIRCUIT LOW (BANK 1)

1. OUTLINE OF DIAGNOSIS

Detect the open or short circuit of tumble generator valve motor.

Judge NG when the overcurrent signal is sent from IC after tumble generator valve driving IC diagnosis.

2. COMPONENT DESCRIPTION

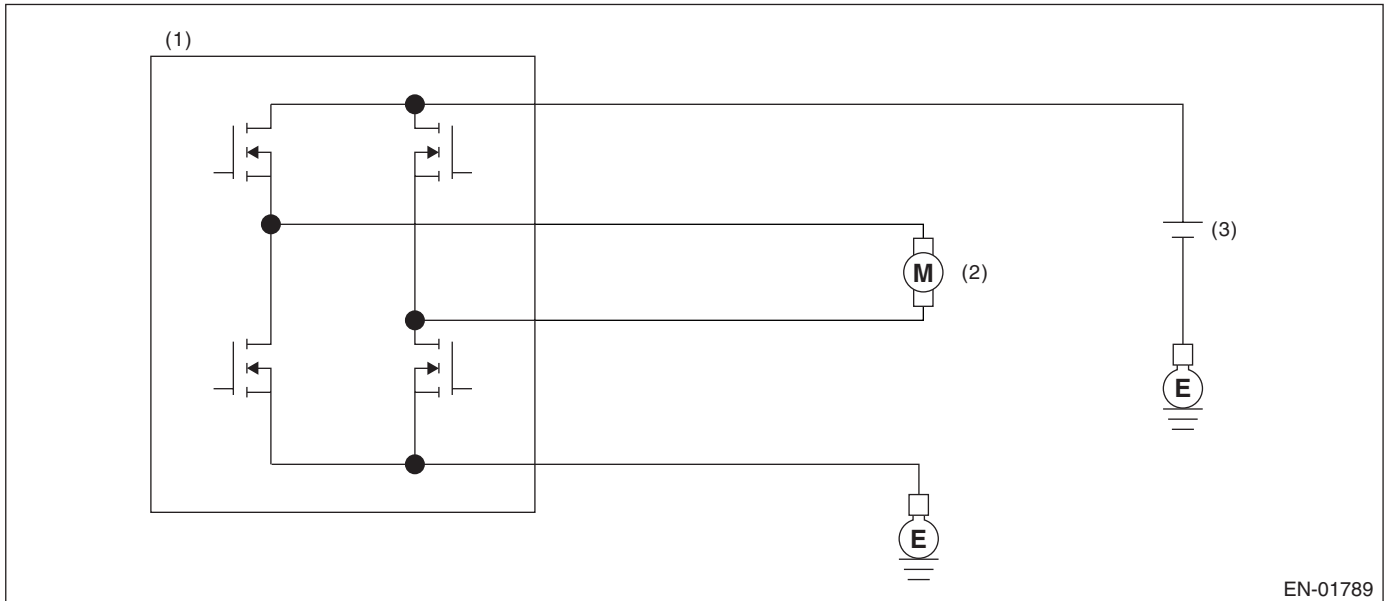

- (1) Engine control module (ECM)
- (2) Tumble generator valve
- (3) Battery

EN-01789

3. ENABLE CONDITION

Secondary Parameters	Enable Conditions
Battery voltage	≥ 10.9 V
ECM output signal	Before set ON → OFF
Tumble generator valve ON signal output time	20 milliseconds or more

4. GENERAL DRIVING CYCLE

Always perform the diagnosis continuously.

5. DIAGNOSTIC METHOD

NG signal is sent to main IC. At the main IC, check the sent signal at each timing which occurs just before the tumble generator valve output is set to ON and OFF, and judge overcurrent NG when the overcurrent NG signal is sent during 1 second in a row. Judge OK and clear the NG when the OK signal is sent.

Judgment Value

Malfunction Criteria	Threshold Value
Open NG signal input	High
Overcurrent NG signal input	Low

Time Needed for Diagnosis: 10 seconds

Malfunction Indicator Light Illumination: Illuminates as soon as malfunction occurs.

Diagnostic Trouble Code (DTC) Detecting Criteria

GENERAL DESCRIPTION

6. DTC CLEAR CONDITION

- When the OK idling cycle was completed 40 times in a row
- When "Clear Memory" was performed

7. MALFUNCTION INDICATOR LIGHT CLEAR CONDITION

- When the OK driving cycle was completed 3 times in a row
- When "Clear Memory" was performed

8. FAIL SAFE

Tumble generator valve control: Not allowed to move tumble generator valve.

9. ECM OPERATION AT DTC SETTING

Memorize the freeze frame data. (For test mode \$02)

DP:DTC P2011 INTAKE MANIFOLD RUNNER CONTROL CIRCUIT / OPEN (BANK 2)

1. OUTLINE OF DIAGNOSIS

Detect the open or short circuit of tumble generator valve motor.

Judge NG when the open signal is sent from IC after tumble generator valve driving IC diagnosis.

2. COMPONENT DESCRIPTION

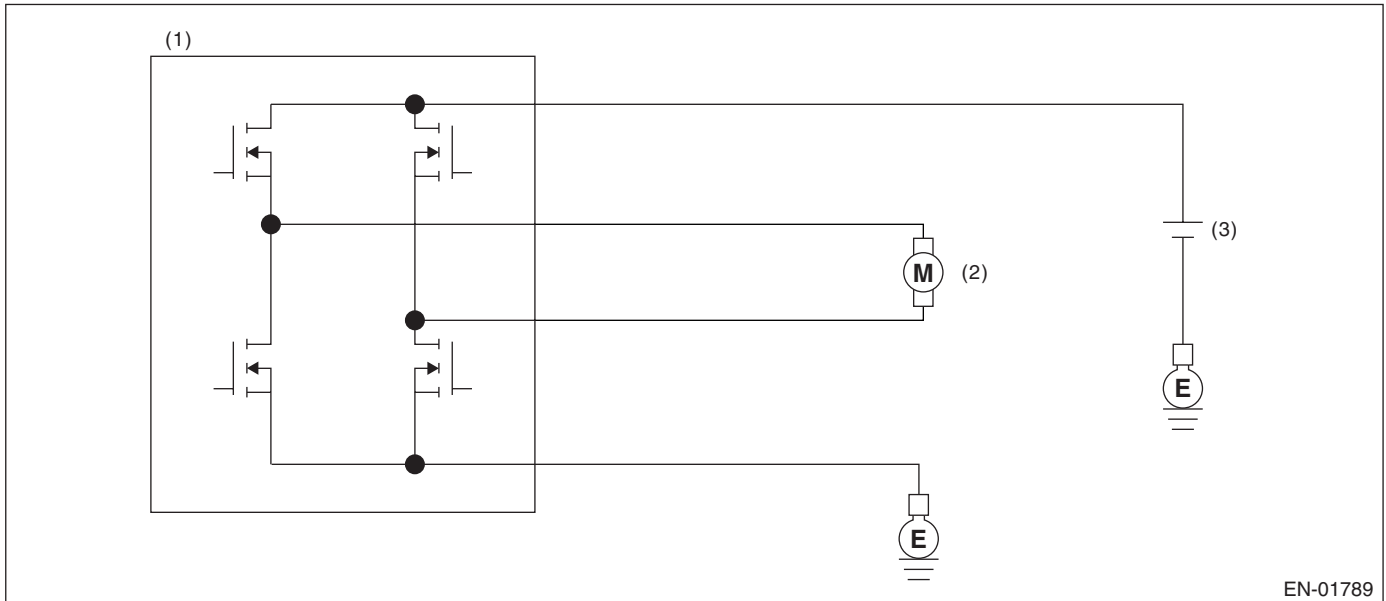

- (1) Engine control module (ECM)
- (2) Tumble generator valve
- (3) Battery

3. ENABLE CONDITION

Secondary Parameters	Enable Conditions
Battery voltage	≥ 10.9 V
ECM output signal	Before set ON → OFF
Tumble generator valve ON signal output time	20 milliseconds or more

4. GENERAL DRIVING CYCLE

Always perform the diagnosis continuously.

5. DIAGNOSTIC METHOD

At the main IC, check the sent signal at each timing which occurs just before the tumble generator valve output is set to ON and OFF, and judge open NG when the open NG signal is sent during 1 second in a row. Judge OK and clear the NG when the OK signal is sent.

Judgment Value

Malfunction Criteria	Threshold Value
Open NG signal input	Low
Overcurrent NG signal input	High

Time Needed for Diagnosis: 10 seconds

Malfunction Indicator Light Illumination: Illuminates as soon as malfunction occurs.

Diagnostic Trouble Code (DTC) Detecting Criteria

GENERAL DESCRIPTION

6. DTC CLEAR CONDITION

- When the OK idling cycle was completed 40 times in a row
- When "Clear Memory" was performed

7. MALFUNCTION INDICATOR LIGHT CLEAR CONDITION

- When the OK driving cycle was completed 3 times in a row
- When "Clear Memory" was performed

8. FAIL SAFE

Tumble generator valve control: Not allowed to move tumble generator valve.

9. ECM OPERATION AT DTC SETTING

Memorize the freeze frame data. (For test mode \$02)

Diagnostic Trouble Code (DTC) Detecting Criteria

GENERAL DESCRIPTION

DQ:DTC P2012 INTAKE MANIFOLD RUNNER CONTROL CIRCUIT LOW (BANK 2)

1. OUTLINE OF DIAGNOSIS

Detect the open or short circuit of tumble generator valve motor.

Judge NG when the overcurrent signal is sent from IC after tumble generator valve driving IC diagnosis.

2. COMPONENT DESCRIPTION

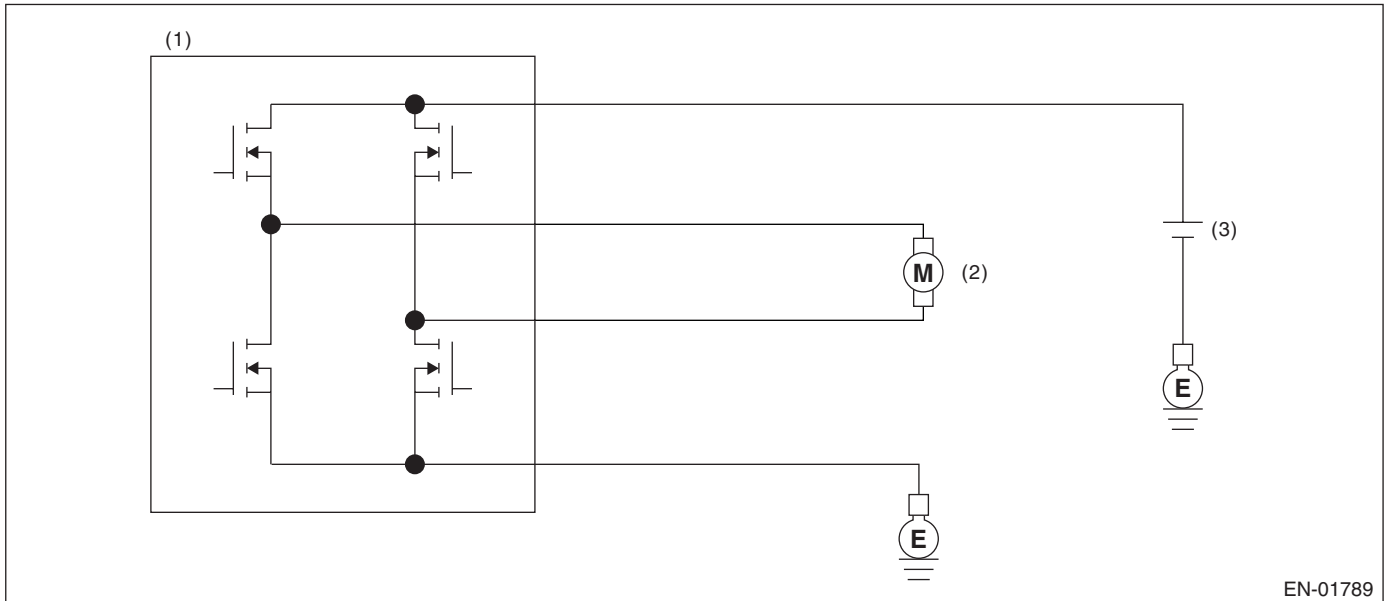

- (1) Engine control module (ECM)
- (2) Tumble generator valve
- (3) Battery

3. ENABLE CONDITION

Secondary Parameters	Enable Conditions
Battery voltage	≥ 10.9 V
ECM output signal	Before set ON → OFF
Tumble generator valve ON signal output time	20 milliseconds or more

4. GENERAL DRIVING CYCLE

Always perform the diagnosis continuously.

5. DIAGNOSTIC METHOD

NG signal is sent to main IC. At the main IC, check the sent signal at each timing which occurs just before the tumble generator valve output is set to ON and OFF, and judge overcurrent NG when the overcurrent NG signal is sent during 1 second in a row. Judge OK and clear the NG when the OK signal is sent.

Judgment Value

Malfunction Criteria	Threshold Value
Open NG signal input	High
Overcurrent NG signal input	Low

Time Needed for Diagnosis: 10 seconds

Malfunction Indicator Light Illumination: Illuminates as soon as malfunction occurs.

Diagnostic Trouble Code (DTC) Detecting Criteria

GENERAL DESCRIPTION

6. DTC CLEAR CONDITION

- When the OK idling cycle was completed 40 times in a row
- When "Clear Memory" was performed

7. MALFUNCTION INDICATOR LIGHT CLEAR CONDITION

- When the OK driving cycle was completed 3 times in a row
- When "Clear Memory" was performed

8. FAIL SAFE

Tumble generator valve control: Not allowed to move tumble generator valve.

9. ECM OPERATION AT DTC SETTING

Memorize the freeze frame data. (For test mode \$02)

DR:DTC P2016 INTAKE MANIFOLD RUNNER POSITION SENSOR / SWITCH CIRCUIT LOW (BANK 1)

1. OUTLINE OF DIAGNOSIS

Detect open or short circuit of tumble generator valve position sensor.
Judge NG when the value is out of standard range.

2. COMPONENT DESCRIPTION

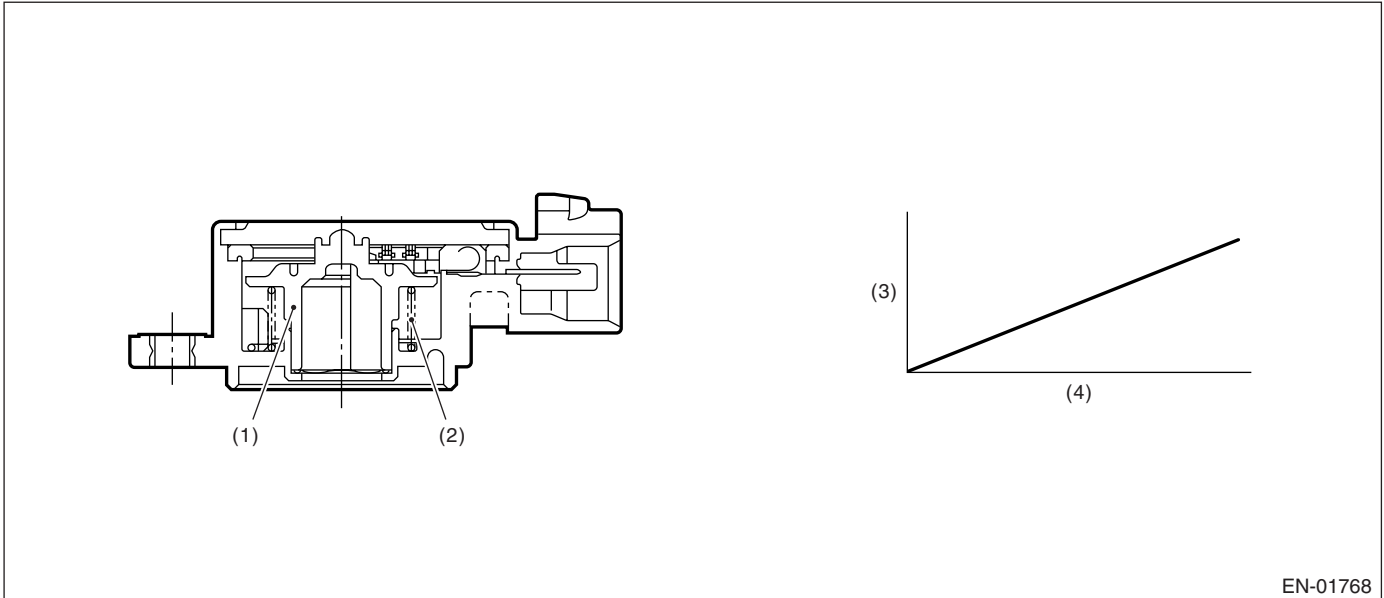

- (1) Rotor
- (2) Return spring
- (3) Voltage (V)
- (4) Tumble generator valve angle (°)

3. ENABLE CONDITION

Secondary Parameters	Enable Conditions
None	

4. GENERAL DRIVING CYCLE

Always perform diagnosis.

5. DIAGNOSTIC METHOD

Judge NG when the continuous time of completing the malfunction criteria below becomes more than the time needed for diagnosis (0.5 seconds). Judge OK and clear NG when the malfunction criteria below are not completed.

Judgment Value

Malfunction Criteria	Threshold Value
Output voltage	< 0.167 V

Time Needed for Diagnosis: 0.5 seconds

Malfunction Indicator Light Illumination: Illuminates as soon as malfunction occurs.

6. DTC CLEAR CONDITION

- When the OK idling cycle was completed 40 times in a row
- When "Clear Memory" was performed

Diagnostic Trouble Code (DTC) Detecting Criteria

GENERAL DESCRIPTION

7. MALFUNCTION INDICATOR LIGHT CLEAR CONDITION

- When the OK driving cycle was completed 3 times in a row
- When "Clear Memory" was performed

8. FAIL SAFE

Tumble generator valve position

- Learning of tumble generator valve position fully closed and date renewed to close side.
- Learning of tumble generator valve position fully opened and date renewed to open side.

9. ECM OPERATION AT DTC SETTING

Memorize the freeze frame data. (For test mode \$02)

DS:DTC P2017 INTAKE MANIFOLD RUNNER POSITION SENSOR / SWITCH CIRCUIT HIGH (BANK 1)

1. OUTLINE OF DIAGNOSIS

Detect open or short circuit of tumble generator valve position sensor.
Judge NG when the value is out of standard range.

2. COMPONENT DESCRIPTION

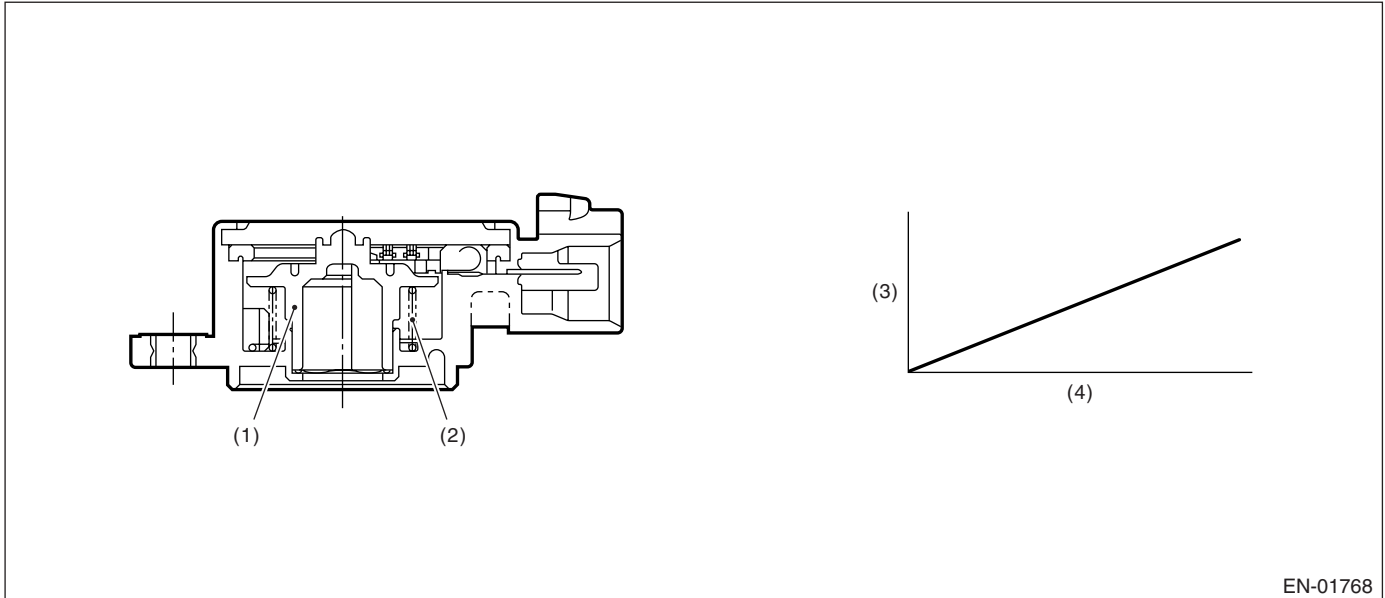

- (1) Rotor
- (2) Return spring
- (3) Voltage (V)
- (4) Tumble generator valve angle (°)

3. ENABLE CONDITION

Secondary Parameters	Enable Conditions
None	

4. GENERAL DRIVING CYCLE

Always perform diagnosis.

5. DIAGNOSTIC METHOD

Judge NG when the continuous time of completing the malfunction criteria below becomes more than the time needed for diagnosis (0.5 seconds). Judge OK and clear NG when the malfunction criteria below are not completed.

Judgment Value

Malfunction Criteria	Threshold Value
Output voltage	≥ 4.843 V

Time Needed for Diagnosis: 0.5 seconds

Malfunction Indicator Light Illumination: Illuminates as soon as malfunction occurs.

6. DTC CLEAR CONDITION

- When the OK idling cycle was completed 40 times in a row
- When "Clear Memory" was performed

Diagnostic Trouble Code (DTC) Detecting Criteria

GENERAL DESCRIPTION

7. MALFUNCTION INDICATOR LIGHT CLEAR CONDITION

- When the OK driving cycle was completed 3 times in a row
- When "Clear Memory" was performed

8. FAIL SAFE

Tumble generator valve position

- Learning of tumble generator valve position fully closed and date renewed to close side.
- Learning of tumble generator valve position fully opened and date renewed to open side.

9. ECM OPERATION AT DTC SETTING

Memorize the freeze frame data. (For test mode \$02)

Diagnostic Trouble Code (DTC) Detecting Criteria

GENERAL DESCRIPTION

DT:DTC P2021 INTAKE MANIFOLD RUNNER POSITION SENSOR / SWITCH CIRCUIT LOW (BANK 2)

1. OUTLINE OF DIAGNOSIS

Detect open or short circuit of tumble generator valve position sensor.
Judge NG when the value is out of standard range.

2. COMPONENT DESCRIPTION

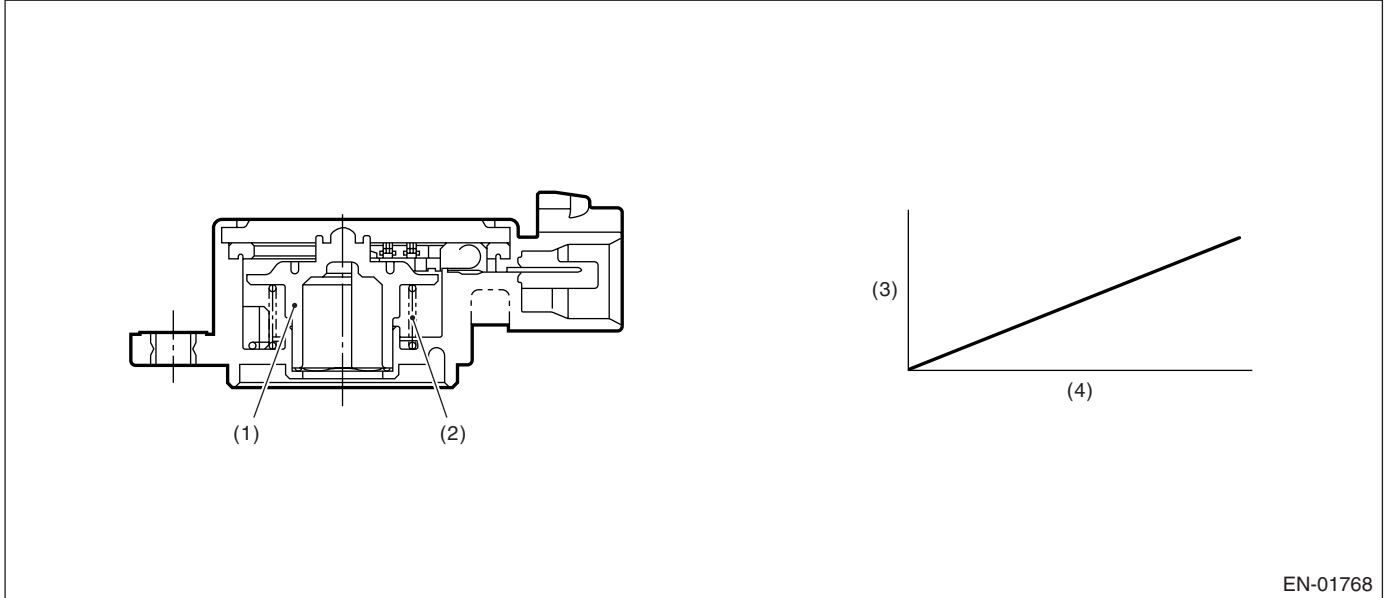

- (1) Rotor
- (2) Return spring
- (3) Voltage (V)
- (4) Tumble generator valve angle (°)

3. ENABLE CONDITION

Secondary Parameters	Enable Conditions
None	

4. GENERAL DRIVING CYCLE

Always perform diagnosis.

5. DIAGNOSTIC METHOD

Judge NG when the continuous time of completing the malfunction criteria below becomes more than the time needed for diagnosis (0.5 seconds). Judge OK and clear NG when the malfunction criteria below are not completed.

Judgment Value

Malfunction Criteria	Threshold Value
Output voltage	< 0.167 V

Time Needed for Diagnosis: 0.5 seconds

Malfunction Indicator Light Illumination: Illuminates as soon as malfunction occurs.

6. DTC CLEAR CONDITION

- When the OK idling cycle was completed 40 times in a row
- When "Clear Memory" was performed

Diagnostic Trouble Code (DTC) Detecting Criteria

GENERAL DESCRIPTION

7. MALFUNCTION INDICATOR LIGHT CLEAR CONDITION

- When the OK driving cycle was completed 3 times in a row
- When "Clear Memory" was performed

8. FAIL SAFE

Tumble generator valve position

- Learning of tumble generator valve position fully closed and date renewed to close side.
- Learning of tumble generator valve position fully opened and date renewed to open side.

9. ECM OPERATION AT DTC SETTING

Memorize the freeze frame data. (For test mode \$02)

DU:DTC P2022 INTAKE MANIFOLD RUNNER POSITION SENSOR / SWITCH CIRCUIT HIGH (BANK 2)

1. OUTLINE OF DIAGNOSIS

Detect open or short circuit of tumble generator valve position sensor.
Judge NG when the value is out of standard range.

2. COMPONENT DESCRIPTION

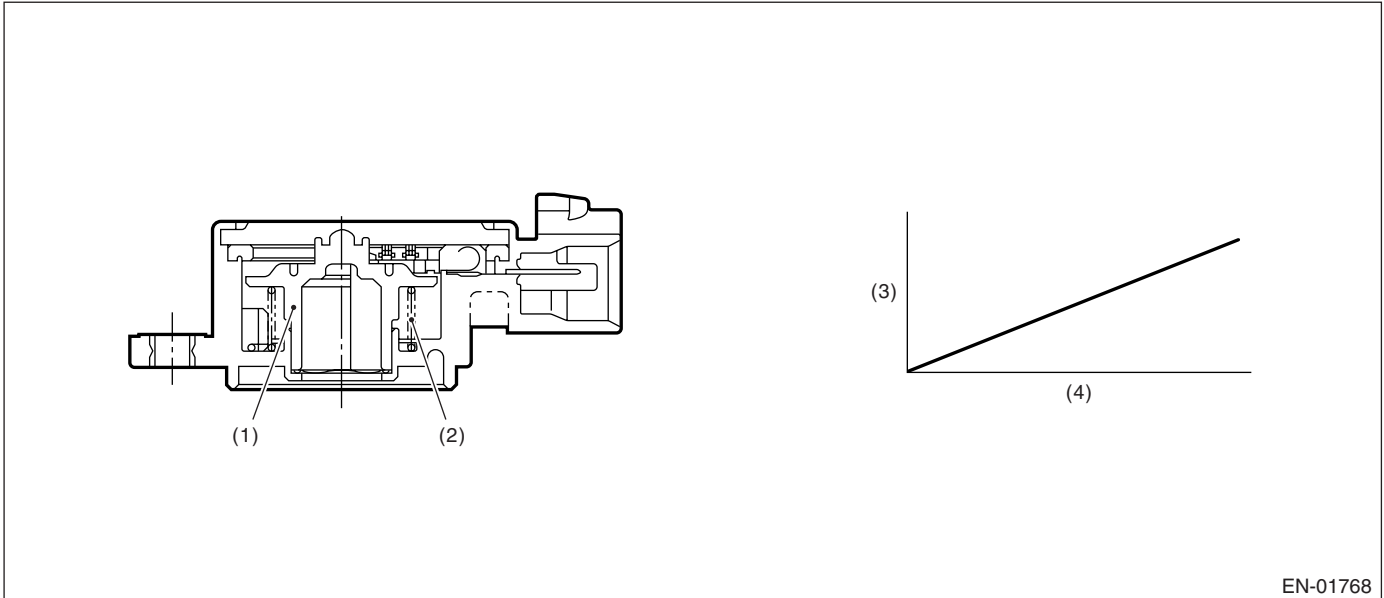

- (1) Rotor
- (2) Return spring
- (3) Voltage (V)
- (4) Tumble generator valve angle (°)

3. ENABLE CONDITION

Secondary Parameters	Enable Conditions
None	

4. GENERAL DRIVING CYCLE

Always perform diagnosis.

5. DIAGNOSTIC METHOD

Judge NG when the continuous time of completing the malfunction criteria below becomes more than the time needed for diagnosis (0.5 seconds). Judge OK and clear NG when the malfunction criteria below are not completed.

Judgment Value

Malfunction Criteria	Threshold Value
Output voltage	≥ 4.843 V

Time Needed for Diagnosis: 0.5 seconds

Malfunction Indicator Light Illumination: Illuminates as soon as malfunction occurs.

6. DTC CLEAR CONDITION

- When the OK idling cycle was completed 40 times in a row
- When "Clear Memory" was performed

Diagnostic Trouble Code (DTC) Detecting Criteria

GENERAL DESCRIPTION

7. MALFUNCTION INDICATOR LIGHT CLEAR CONDITION

- When the OK driving cycle was completed 3 times in a row
- When "Clear Memory" was performed

8. FAIL SAFE

Tumble generator valve position

- Learning of tumble generator valve position fully closed and date renewed to close side.
- Learning of tumble generator valve position fully opened and date renewed to open side.

9. ECM OPERATION AT DTC SETTING

Memorize the freeze frame data. (For test mode \$02)

Diagnostic Trouble Code (DTC) Detecting Criteria

GENERAL DESCRIPTION

DV:DTC P2088 OCV SOLENOID VALVE SIGNAL A CIRCUIT OPEN (BANK 1)

1. OUTLINE OF DIAGNOSIS

Detect open or short circuit of oil flow control solenoid valve.

Judge open NG when the current flow is small whereas duty signal is large, and judge short NG when the current flow is large whereas duty signal is small.

2. ENABLE CONDITION

Secondary Parameter	Enable Condition
Battery voltage	≥ 10.9 V

3. GENERAL DRIVING CYCLE

Always perform the diagnosis continuously.

4. DIAGNOSTIC METHOD

• Abnormality Judgment

Judge NG when the continuous time of completing the malfunction criteria below becomes more than 2 seconds.

Judgment Value

Malfunction Criteria	Threshold Value
OCV solenoid valve duty	$\geq 99.61\%$
OCV solenoid valve present current	< 0.306 A

Time Needed for Diagnosis: 2,000 milliseconds

Malfunction Indicator Light Illumination: Illuminates as soon as malfunction occurs.

• Normality Judgment

Judge OK and clear NG when the continuous time of completing the malfunction criteria below becomes more than 2 seconds.

Judgment Value

Malfunction Criteria	Threshold Value
Target current value of OCV solenoid valve	$\geq 0.14\%$
Target current value of OCV solenoid valve – Control current value of OCV solenoid valve	≥ 0.08 A

5. DTC CLEAR CONDITION

- When the OK idling cycle was completed 40 times in a row
- When “Clear Memory” was performed

6. MALFUNCTION INDICATOR LIGHT CLEAR CONDITION

- When the OK driving cycle was completed 3 times in a row
- When “Clear Memory” was performed

Diagnostic Trouble Code (DTC) Detecting Criteria

GENERAL DESCRIPTION

7. FAIL SAFE

- Ignition timing whole learning compensation:
 - Enter the initial value (whole learning compensation factor = 0.5, Variable amount of whole learning compensation factor = 0.25) to the whole learning compensation factor and variable amount of whole learning compensation factor when IG OFF, and then make the whole learning incomplete.
 - Enter the initial value (whole learning compensation factor = 0.5, Variable amount of whole learning compensation factor = 0.25) to the whole learning compensation factor and variable amount of whole learning compensation factor when making a normality judgment from abnormality judgment, and then make the whole learning incomplete.
- Ignition timing partial learning compensation:
 - Enter the initial value (0°CA) to the compensation value of partial learning zone when IG OFF.
 - Enter the initial value (0°CA) to the compensation value of partial learning zone when making a normality judgment from abnormality judgment.
- AVCS control:
 - Most timing retard learning is not complete or most timing retard learning completion is not experienced.
 - ISC feedback compensation: Do not perform the AVCS actual timing advance compensation.
 - Make the OCV driving Duty to be the given value (9.36%).

8. ECM OPERATION AT DTC SETTING

Memorize the freeze frame data. (For test mode \$02)

Diagnostic Trouble Code (DTC) Detecting Criteria

GENERAL DESCRIPTION

DW:DTC P2089 OCV SOLENOID VALVE SIGNAL A CIRCUIT SHORT (BANK 1)

1. OUTLINE OF DIAGNOSIS

Detect open or short circuit of oil flow control solenoid valve.

Judge open NG when the current flow is small whereas duty signal is large, and judge short NG when the current flow is large whereas duty signal is small.

2. ENABLE CONDITION

Secondary Parameter	Enable Condition
Battery voltage	≥ 10.9 V

3. GENERAL DRIVING CYCLE

Always perform the diagnosis continuously.

4. DIAGNOSTIC METHOD

• Abnormality Judgment

Judge NG when the continuous time of completing the malfunction criteria below becomes more than 2 seconds.

Judgment Value

Malfunction Criteria	Threshold Value
OCV solenoid valve duty	$< 0.39\%$
OCV solenoid valve present current	≥ 0.306 A

Time Needed for Diagnosis: 2,000 milliseconds

Malfunction Indicator Light Illumination: Illuminates as soon as malfunction occurs.

• Normality Judgment

Judge OK and clear NG when the continuous time of completing the malfunction criteria below becomes more than 2 seconds.

Judgment Value

Malfunction Criteria	Threshold Value
Target current value of OCV solenoid valve – Control current value of OCV solenoid valve	< 0.08 A

5. DTC CLEAR CONDITION

- When the OK idling cycle was completed 40 times in a row
- When “Clear Memory” was performed

6. MALFUNCTION INDICATOR LIGHT CLEAR CONDITION

- When the OK driving cycle was completed 3 times in a row
- When “Clear Memory” was performed

Diagnostic Trouble Code (DTC) Detecting Criteria

GENERAL DESCRIPTION

7. FAIL SAFE

- Ignition timing whole learning compensation:
 - Enter the initial value (whole learning compensation factor = 0.5, Variable amount of whole learning compensation factor = 0.25) to the whole learning compensation factor and variable amount of whole learning compensation factor when IG OFF, and then make the whole learning incomplete.
 - Enter the initial value (whole learning compensation factor = 0.5, Variable amount of whole learning compensation factor = 0.25) to the whole learning compensation factor and variable amount of whole learning compensation factor when making a normality judgment from abnormality judgment, and then make the whole learning incomplete.
- Ignition timing partial learning compensation:
 - Enter the initial value (0°CA) to the compensation value of partial learning zone when IG OFF.
 - Enter the initial value (0°CA) to the compensation value of partial learning zone when making a normality judgment from abnormality judgment.
- AVCS control:
 - Most timing retard learning is not complete or most timing retard learning completion is not experienced.
 - ISC feedback compensation: Do not perform the AVCS actual timing advance compensation.
 - Make the OCV driving Duty to be the given value (9.36%).

8. ECM OPERATION AT DTC SETTING

Memorize the freeze frame data. (For test mode \$02)

Diagnostic Trouble Code (DTC) Detecting Criteria

GENERAL DESCRIPTION

DX:DTC P2092 OCV SOLENOID VALVE SIGNAL A CIRCUIT OPEN (BANK 2)

1. OUTLINE OF DIAGNOSIS

Detect open or short circuit of oil flow control valve solenoid.

Judge open NG when the current flow is small whereas duty signal is large, and judge short NG when the current flow is large whereas duty signal is small.

2. ENABLE CONDITION

Secondary Parameter	Enable Condition
Battery voltage	≥ 10.9 V

3. GENERAL DRIVING CYCLE

Always perform the diagnosis continuously.

4. DIAGNOSTIC METHOD

• Abnormality Judgment

Judge NG when the continuous time of completing the malfunction criteria below becomes more than 2 seconds.

Judgment Value

Malfunction Criteria	Threshold Value
OCV control duty	$\geq 99.61\%$
OCV control present current	< 0.306 A

Time Needed for Diagnosis: 2000 milliseconds

Malfunction Indicator Light Illumination: Illuminates as soon as malfunction occurs.

• Normality Judgment

Judge OK and clear NG when the continuous time of completing the malfunction criteria below becomes more than 2 seconds.

Judgment Value

Malfunction Criteria	Threshold Value
Target current value of OCV	$\geq 0.14\%$
Target current value of OCV – Control current value of OCV	≥ 0.08 A

5. DTC CLEAR CONDITION

- When the OK idling cycle was completed 40 times in a row
- When “Clear Memory” was performed

6. MALFUNCTION INDICATOR LIGHT CLEAR CONDITION

- When the OK driving cycle was completed 3 times in a row
- When “Clear Memory” was performed

Diagnostic Trouble Code (DTC) Detecting Criteria

GENERAL DESCRIPTION

7. FAIL SAFE

- Ignition timing whole learning compensation:
 - Enter the initial value (whole learning compensation factor = 0.5, Variable amount of whole learning compensation factor = 0.25) to the whole learning compensation factor and variable amount of whole learning compensation factor when IG OFF, and then make the whole learning incomplete.
 - Enter the initial value (whole learning compensation factor = 0.5, Variable amount of whole learning compensation factor = 0.25) to the whole learning compensation factor and variable amount of whole learning compensation factor when making a normality judgment from abnormality judgment, and then make the whole learning incomplete.
- Ignition timing partial learning compensation:
 - Enter the initial value (0°CA) to the compensation value of partial learning zone when IG OFF.
 - Enter the initial value (0°CA) to the compensation value of partial learning zone when making a normality judgment from abnormality judgment.
- AVCS control:
 - Most timing retard learning is not complete or most timing retard learning completion is not experienced.
 - ISC feedback compensation: Do not perform the AVCS actual timing advance compensation.
 - Make the OCV driving Duty to be the given value (9.36%).

8. ECM OPERATION AT DTC SETTING

Memorize the freeze frame data. (For test mode \$02)

Diagnostic Trouble Code (DTC) Detecting Criteria

GENERAL DESCRIPTION

DY:DTC P2093 INTAKE CAMSHAFT POSITION ACTUATOR CONTROL CIRCUIT HIGH (BANK 2)

1. OUTLINE OF DIAGNOSIS

Detect open or short circuit of oil flow control valve solenoid.

Judge open NG when the current flow is small whereas duty signal is large, and judge short NG when the current flow is large whereas duty signal is small.

2. ENABLE CONDITION

Secondary Parameter	Enable Condition
Battery voltage	≥ 10.9 V

3. GENERAL DRIVING CYCLE

Always perform the diagnosis continuously.

4. DIAGNOSTIC METHOD

• Abnormality Judgment

Judge NG when the continuous time of completing the malfunction criteria below becomes more than 2 seconds.

Judgment Value

Malfunction Criteria	Threshold Value
OCV control duty	$< 0.39\%$
OCV control present current	≥ 0.306 A

Time Needed for Diagnosis: 2000 milliseconds

Malfunction Indicator Light Illumination: Illuminates as soon as malfunction occurs.

• Normality Judgment

Judge OK and clear NG when the continuous time of completing the malfunction criteria below becomes more than 2 seconds.

Judgment Value

Malfunction Criteria	Threshold Value
Target current value of OCV – Control current value of OCV	< 0.08 A

5. DTC CLEAR CONDITION

- When the OK idling cycle was completed 40 times in a row
- When “Clear Memory” was performed

6. MALFUNCTION INDICATOR LIGHT CLEAR CONDITION

- When the OK driving cycle was completed 3 times in a row
- When “Clear Memory” was performed

Diagnostic Trouble Code (DTC) Detecting Criteria

GENERAL DESCRIPTION

7. FAIL SAFE

- Ignition timing whole learning compensation:
 - Enter the initial value (whole learning compensation factor = 0.5, Variable amount of whole learning compensation factor = 0.25) to the whole learning compensation factor and variable amount of whole learning compensation factor when IG OFF, and then make the whole learning incomplete.
 - Enter the initial value (whole learning compensation factor = 0.5, Variable amount of whole learning compensation factor = 0.25) to the whole learning compensation factor and variable amount of whole learning compensation factor when making a normality judgment from abnormality judgment, and then make the whole learning incomplete.
- Ignition timing partial learning compensation:
 - Enter the initial value (0°CA) to the compensation value of partial learning zone when IG OFF.
 - Enter the initial value (0°CA) to the compensation value of partial learning zone when making a normality judgment from abnormality judgment.
- AVCS control:
 - Most timing retard learning is not complete or most timing retard learning completion is not experienced.
 - ISC feedback compensation: Do not perform the AVCS actual timing advance compensation.
 - Make the OCV driving Duty to be the given value (9.36%).

8. ECM OPERATION AT DTC SETTING

Memorize the freeze frame data. (For test mode \$02)

Diagnostic Trouble Code (DTC) Detecting Criteria

GENERAL DESCRIPTION

DZ:DTC P2096 POST CATALYST FUEL TRIM SYSTEM TOO LEAN BANK 1

1. OUTLINE OF DIAGNOSIS

Detect the malfunction of fuel system from the amount of sub feedback control, if it is shifted to rich or lean. If the sub feedback amount from the engine started till ignition switch OFF is shifted to rich or lean, judge as insufficient sub feedback amount.

If insufficient, change the sub feedback amount guard value and shift judge line, and increment the guard operation counter (tentative NG counter).

Judge NG when the guard operation counter (tentative NG counter) exceeds the specified value and sub feedback amount is shifted to rich or lean.

2. COMPONENT DESCRIPTION

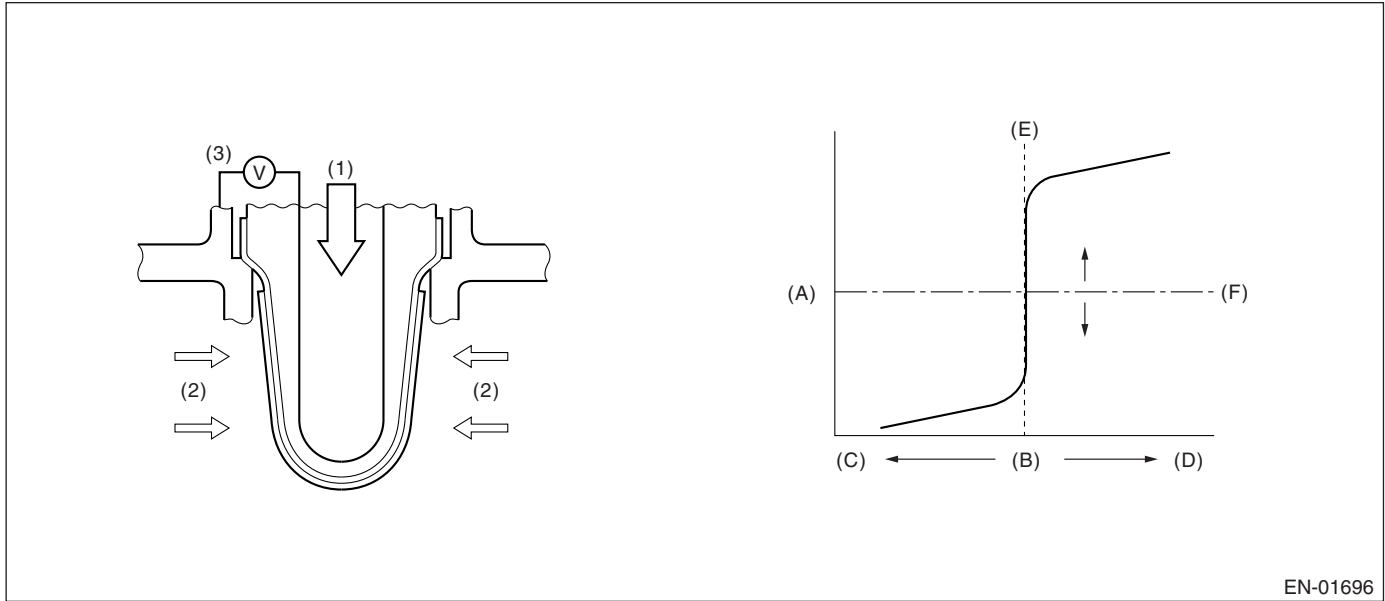

- (1) Atmosphere
- (2) Exhaust gas
- (3) Electromotive force

- (A) Electromotive force
- (B) Air fuel ratio
- (C) Rich
- (D) Lean
- (E) Theoretical air fuel ratio
- (F) Comparative voltage

3. ENABLE CONDITION

Secondary Parameters	Enable Conditions
Continuous time of completing all conditions	1 second or more
Sub feedback learning enable condition	Completed

4. GENERAL DRIVING CYCLE

Perform the diagnosis continuously at a constant speed at more than approx. 75 km/h (47 MPH).

Diagnostic Trouble Code (DTC) Detecting Criteria

GENERAL DESCRIPTION

5. DIAGNOSTIC METHOD

Judge NG when the continuous time of completing the malfunction criteria becomes more than 5 seconds. Judge OK and clear NG when the continuous time of incompleting the malfunction criteria becomes more than 5 seconds.

Judgment Value

Malfunction Criteria	Threshold Value
Sub feedback learning value	< -0.018

Time Needed for Diagnosis: 5 seconds

Malfunction Indicator Light Illumination: Illuminates when malfunction occurs in 2 continuous driving cycles.

6. DTC CLEAR CONDITION

- When the OK idling cycle was completed 40 times in a row
- When "Clear Memory" was performed

7. MALFUNCTION INDICATOR LIGHT CLEAR CONDITION

- When OK with similar drive in 3 drive cycles.
- When "Clear Memory" was performed

8. FAIL SAFE

None

9. ECM OPERATION AT DTC SETTING

Memorize the freeze frame data. (For test mode \$02)

Diagnostic Trouble Code (DTC) Detecting Criteria

GENERAL DESCRIPTION

EA:DTC P2097 POST CATALYST FUEL TRIM SYSTEM TOO RICH BANK 1

1. OUTLINE OF DIAGNOSIS

Detect the malfunction of fuel system from the amount of sub feedback control, if it is shifted to rich or lean. If the sub feedback amount from the engine started till ignition switch OFF is shifted to rich or lean, judge as insufficient sub feedback amount.

If insufficient, change the sub feedback amount guard value and shift judge line, and increment the guard operation counter (tentative NG counter).

Judge NG when the guard operation counter (tentative NG counter) exceeds the specified value and sub feedback amount is shifted to rich or lean.

2. COMPONENT DESCRIPTION

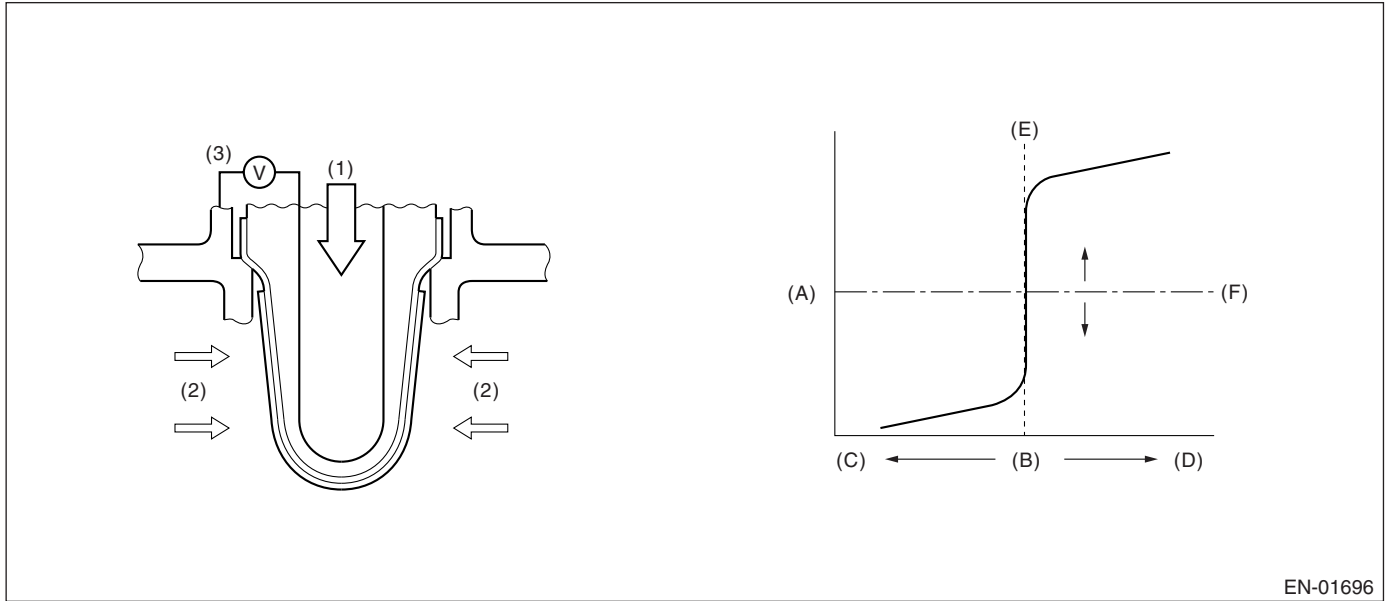

- (1) Atmosphere
- (2) Exhaust gas
- (3) Electromotive force

- (A) Electromotive force
- (B) Air fuel ratio
- (C) Rich
- (D) Lean
- (E) Theoretical air fuel ratio
- (F) Comparative voltage

3. ENABLE CONDITION

Secondary Parameters	Enable Conditions
Continuous time of completing all conditions	1 second or more
Sub feedback learning enable condition	Completed

4. GENERAL DRIVING CYCLE

Perform the diagnosis continuously at a constant speed at more than approx. 75 km/h (47 MPH).

Diagnostic Trouble Code (DTC) Detecting Criteria

GENERAL DESCRIPTION

5. DIAGNOSTIC METHOD

Judge NG when the continuous time of completing the malfunction criteria below becomes more than 5 seconds.

Judge OK and clear NG when the continuous time of completing the malfunction criteria below becomes more than 5 seconds.

Judgment Value

Malfunction Criteria	Threshold Value
Sub feedback learning value	≥ 0.018
Count of limits moving to lean	≥ 4 count
Ratio of time for oxygen sensor upper or lower to time or rich time/lean time	≤ 9 (AT model) ≤ 5.7 (MT model)

Time Needed for Diagnosis: 5 seconds

Malfunction Indicator Light Illumination: Illuminates when malfunction occurs in 2 continuous drive cycles.

6. DTC CLEAR CONDITION

- When the OK idling cycle was completed 40 times in a row
- When "Clear Memory" was performed

7. MALFUNCTION INDICATOR LIGHT CLEAR CONDITION

- When OK with similar drive in 3 drive cycles.
- When "Clear Memory" was performed

8. FAIL SAFE

None

9. ECM OPERATION AT DTC SETTING

Memorize the freeze frame data. (For test mode \$02)

EB:DTC P2101 THROTTLE ACTUATOR CONTROL MOTOR CIRCUIT RANGE/ PERFORMANCE

1. OUTLINE OF DIAGNOSIS

Judge NG when the motor current becomes large or drive circuit is heated.

2. COMPONENT DESCRIPTION

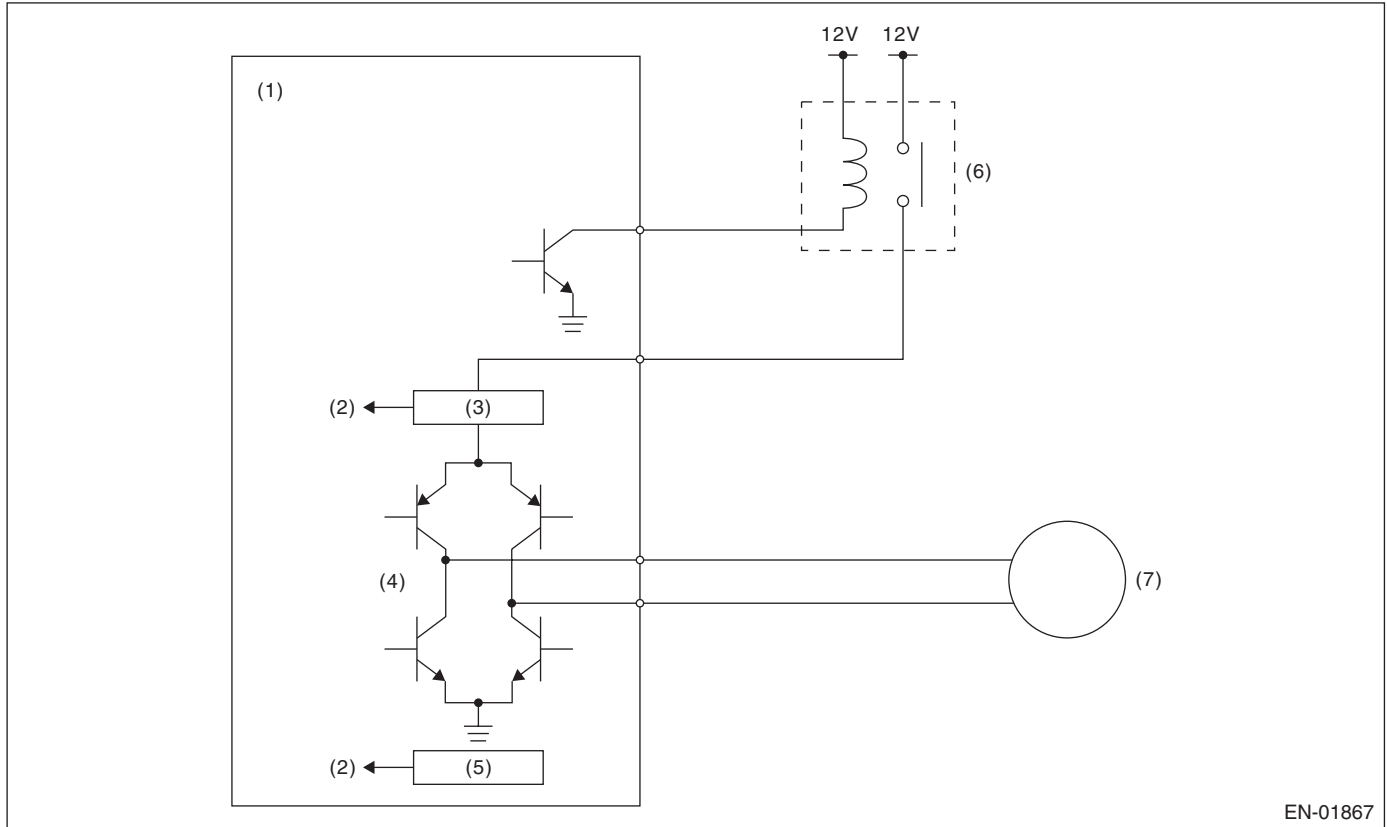

EN-01867

- | | | |
|-----------------------------------|---------------------------------------|-----------|
| (1) Engine control unit (ECM) | (4) Drive circuit | (7) Motor |
| (2) Detection circuit | (5) Temperature detection circuit | |
| (3) Overcurrent detection circuit | (6) Electronic control throttle relay | |

3. ENABLE CONDITION

Secondary Parameters	Enable Conditions
Under control of electronic control throttle	ON
Ignition switch	ON

4. GENERAL DRIVING CYCLE

Always perform the diagnosis continuously.

5. DIAGNOSTIC METHOD

• Abnormality Judgment

Judge OK and clear the NG when the malfunction criteria below are completed.

Judgment Value

Malfunction Criteria	Threshold Value
Motor current	$\leq 8 \text{ A}$
Drive circuit inner temperature	$\leq 175^\circ\text{C}$ (347°F)

Diagnostic Trouble Code (DTC) Detecting Criteria

GENERAL DESCRIPTION

Time Needed for Diagnosis:

- 500 milliseconds (NG judgment)
- 2,000 milliseconds (OK judgment)

Malfunction Indicator Light Illumination: Illuminates as soon as malfunction occurs.

6. DTC CLEAR CONDITION

- When the OK idling cycle was completed 40 times in a row
- When “Clear Memory” was performed (Only with engine stopped)

7. MALFUNCTION INDICATOR LIGHT CLEAR CONDITION

- When the OK driving cycle was completed 3 times in a row
- When “Clear Memory” was performed (Only with engine stopped)

8. FAIL SAFE

Stop the continuity to the electronic control throttle motor. (Fix the throttle opening angle to 6°.)

9. ECM OPERATION AT DTC SETTING

Memorize the freeze frame data. (For test mode \$02)

EC:DTC P2102 THROTTLE ACTUATOR CONTROL MOTOR CIRCUIT LOW

1. OUTLINE OF DIAGNOSIS

Judge NG when the electronic control throttle power is not supplied even when ECM sets the electronic throttle control relay to ON.

2. COMPONENT DESCRIPTION

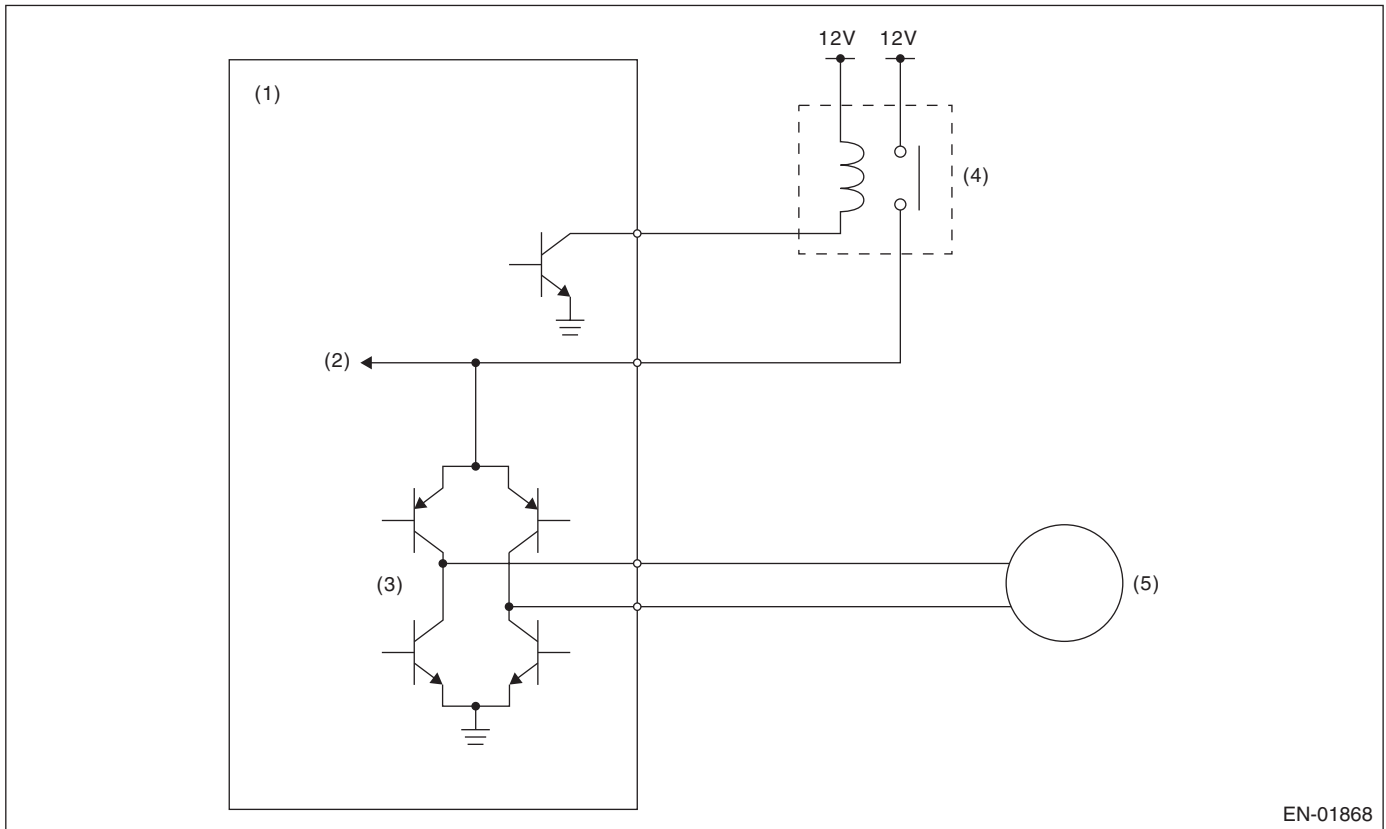

EN-01868

- | | | |
|---------------------------------|---------------------------------------|-----------|
| (1) Engine control module (ECM) | (3) Drive circuit | (5) Motor |
| (2) Voltage detection circuit | (4) Electronic control throttle relay | |

3. ENABLE CONDITION

Secondary Parameters	Enable Conditions
Electronic control throttle relay output	ON
Battery voltage	≥ 6 V

4. GENERAL DRIVING CYCLE

Always perform the diagnosis continuously.

5. DIAGNOSTIC METHOD

• Abnormality Judgment

Judge NG when continuous time of completing the malfunction criteria below becomes more than 0.5 seconds.

Judgment Value

Malfunction Criteria	Threshold Value
Motor power voltage	≤ 5 V

Diagnostic Trouble Code (DTC) Detecting Criteria

GENERAL DESCRIPTION

Time Needed for Diagnosis:

- 400 milliseconds (For NG)
- 2,000 milliseconds (For OK)

Malfunction Indicator Light Illumination: Illuminates as soon as malfunction occurs.

6. DTC CLEAR CONDITION

- When the OK idling cycle was completed 40 times in a row
- When "Clear Memory" was performed (Only with engine stopped)

7. MALFUNCTION INDICATOR LIGHT CLEAR CONDITION

- When the OK driving cycle was completed 3 times in a row
- When "Clear Memory" was performed (Only with engine stopped)

8. FAIL SAFE

Stop the continuity to the electronic control throttle motor. (Fix the throttle opening angle to 6°.)

9. ECM OPERATION AT DTC SETTING

Memorize the freeze frame data. (For test mode \$02)

ED:DTC P2103 THROTTLE ACTUATOR CONTROL MOTOR CIRCUIT HIGH

1. OUTLINE OF DIAGNOSIS

Judge NG when the electronic control throttle power is not supplied even when ECM sets the electric throttle control relay to OFF.

2. COMPONENT DESCRIPTION

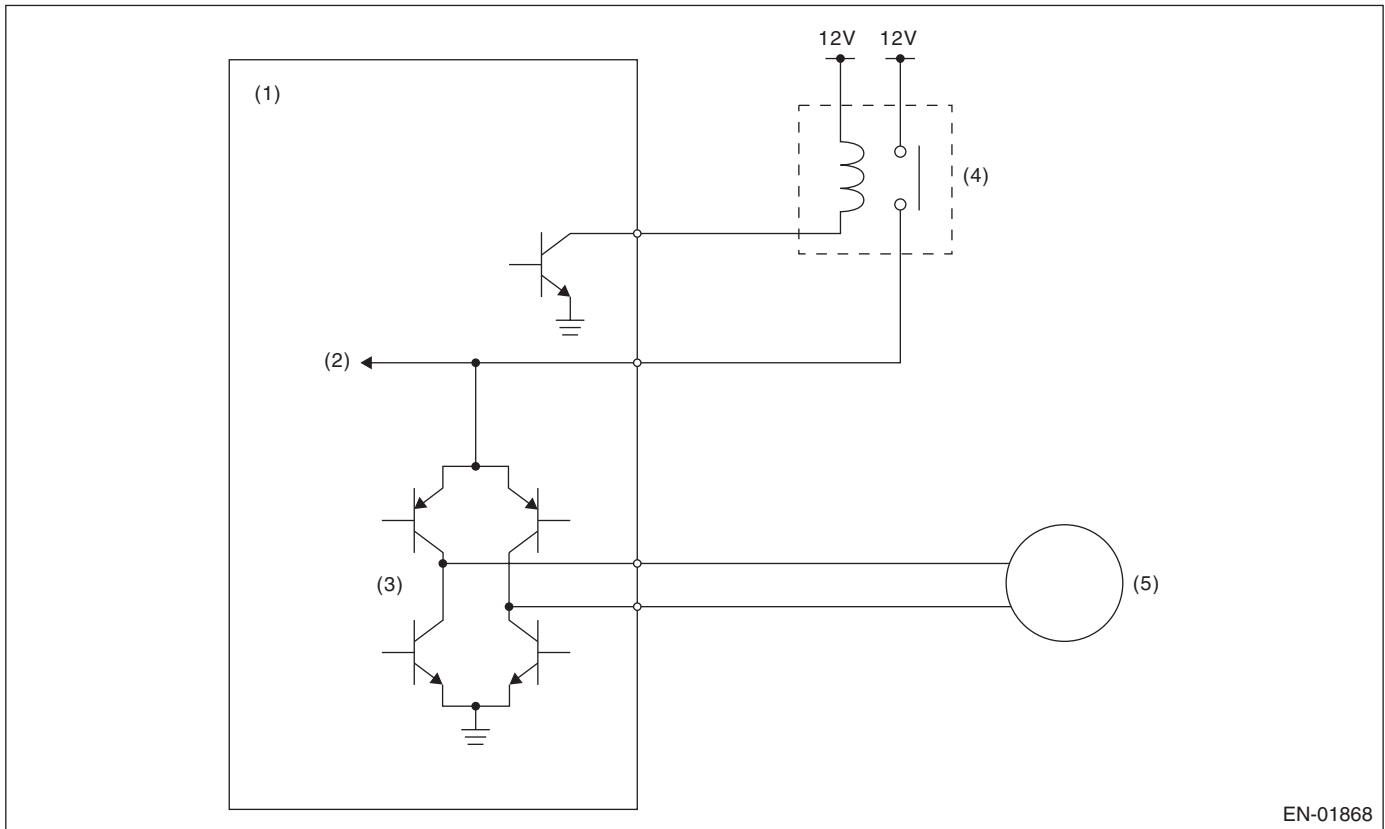

EN-01868

- | | | |
|---------------------------------|---------------------------------------|-----------|
| (1) Engine control module (ECM) | (3) Drive circuit | (5) Motor |
| (2) Voltage detection circuit | (4) Electronic throttle control relay | |

3. ENABLE CONDITION

Secondary Parameters	Enable Conditions
Electronic throttle control relay output	OFF
Battery voltage	$\geq 6 \text{ V}$

4. GENERAL DRIVING CYCLE

- Ignition switch ON → OFF
- Ignition switch OFF → ON (After clear memory only)

5. DIAGNOSTIC METHOD

Judge OK and clear the NG when the malfunction criteria below are completed.

Judgment Value

Malfunction Criteria	Threshold Value
Motor power voltage	$\leq 5 \text{ V}$

Time Needed for Diagnosis:

- 600 milliseconds (For NG)
- 400 milliseconds (For OK)

Diagnostic Trouble Code (DTC) Detecting Criteria

GENERAL DESCRIPTION

Malfunction Indicator Light Illumination: Illuminates as soon as malfunction occurs.

6. DTC CLEAR CONDITION

- When the OK idling cycle was completed 40 times in a row
- When "Clear Memory" was performed (Only with engine stopped)

7. MALFUNCTION INDICATOR LIGHT CLEAR CONDITION

- When the OK driving cycle was completed 3 times in a row
- When "Clear Memory" was performed (Only with engine stopped)

8. FAIL SAFE

Stop the continuity to the electronic control throttle motor. (Fix the throttle opening angle to 6°.)

9. ECM OPERATION AT DTC SETTING

Memorize the freeze frame data. (For test mode \$02)

Diagnostic Trouble Code (DTC) Detecting Criteria

GENERAL DESCRIPTION

EE:DTC P2109 THROTTLE/PEDAL POSITION SENSOR A MINIMUM STOP PERFORMANCE

1. OUTLINE OF DIAGNOSIS

Judge NG when all close point learning cannot be conducted or an abnormal value is detected.

2. COMPONENT DESCRIPTION

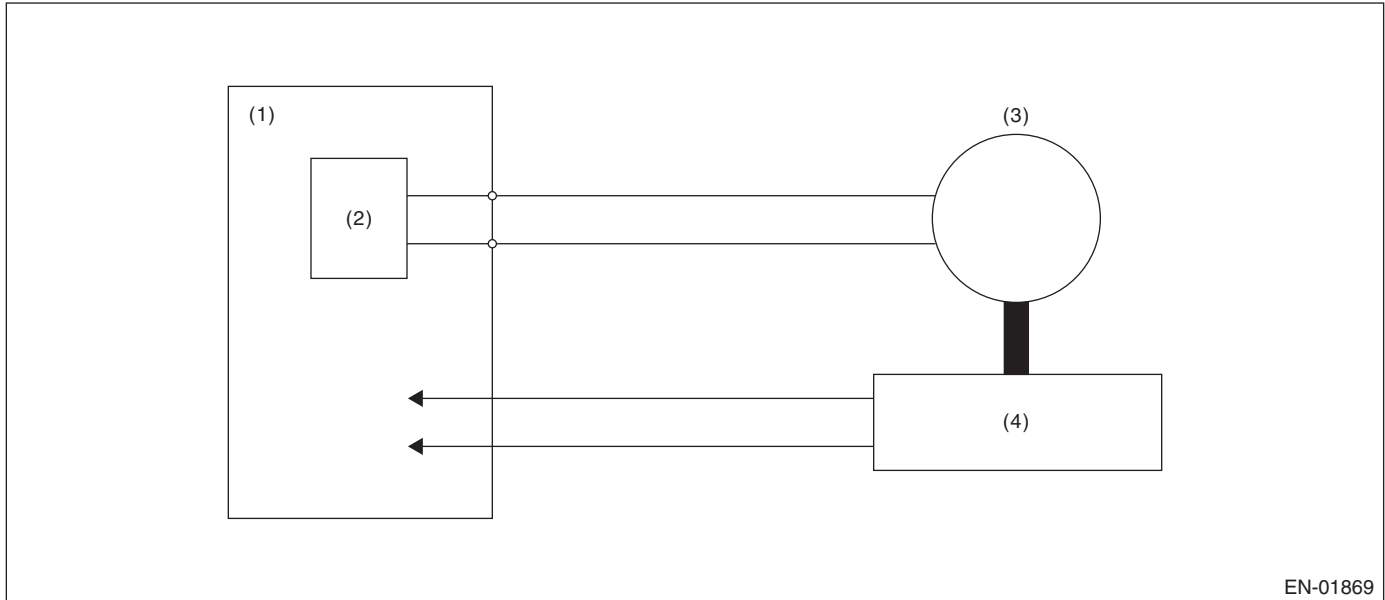

EN-01869

- | | |
|---------------------------------|------------------------------|
| (1) Engine control module (ECM) | (3) Motor |
| (2) Drive circuit | (4) Throttle position sensor |

3. ENABLE CONDITION

Secondary Parameters	Enable Conditions
Ignition switch	ON → OFF
Ignition switch (after clear memory only)	OFF → ON

4. GENERAL DRIVING CYCLE

Perform the diagnosis at all close point learning.

5. DIAGNOSTIC METHOD

Judge OK and clear the NG when the malfunction criteria below are completed.

Judgment Value

Malfunction Criteria	Threshold Value
Throttle sensor opening angle at all close point learning	10.127° — 19.872°
Throttle opening angle when ignition switch is ON — Minimum stop position for throttle	≥ 1.683°

Time Needed for Diagnosis: 8 — 80 milliseconds

Malfunction Indicator Light Illumination: Illuminates as soon as malfunction occurs.

6. DTC CLEAR CONDITION

- When the OK idling cycle was completed 40 times in a row
- When “Clear Memory” was performed (Only with engine stopped)

Diagnostic Trouble Code (DTC) Detecting Criteria

GENERAL DESCRIPTION

7. MALFUNCTION INDICATOR LIGHT CLEAR CONDITION

- When the OK driving cycle was completed 3 times in a row
- When “Clear Memory” was performed (Only with engine stopped)

8. FAIL SAFE

Stop the continuity to the electronic control throttle motor. (Fix the throttle opening angle to 6°.)

9. ECM OPERATION AT DTC SETTING

Memorize the freeze frame data. (For test mode \$02)

EF:DTC P2122 THROTTLE/PEDAL POSITION SENSOR/SWITCH “D” CIRCUIT LOW INPUT

1. OUTLINE OF DIAGNOSIS

Detect the open or short circuit of accelerator pedal position sensor 1.
Judge NG when out of the standard value.

2. COMPONENT DESCRIPTION

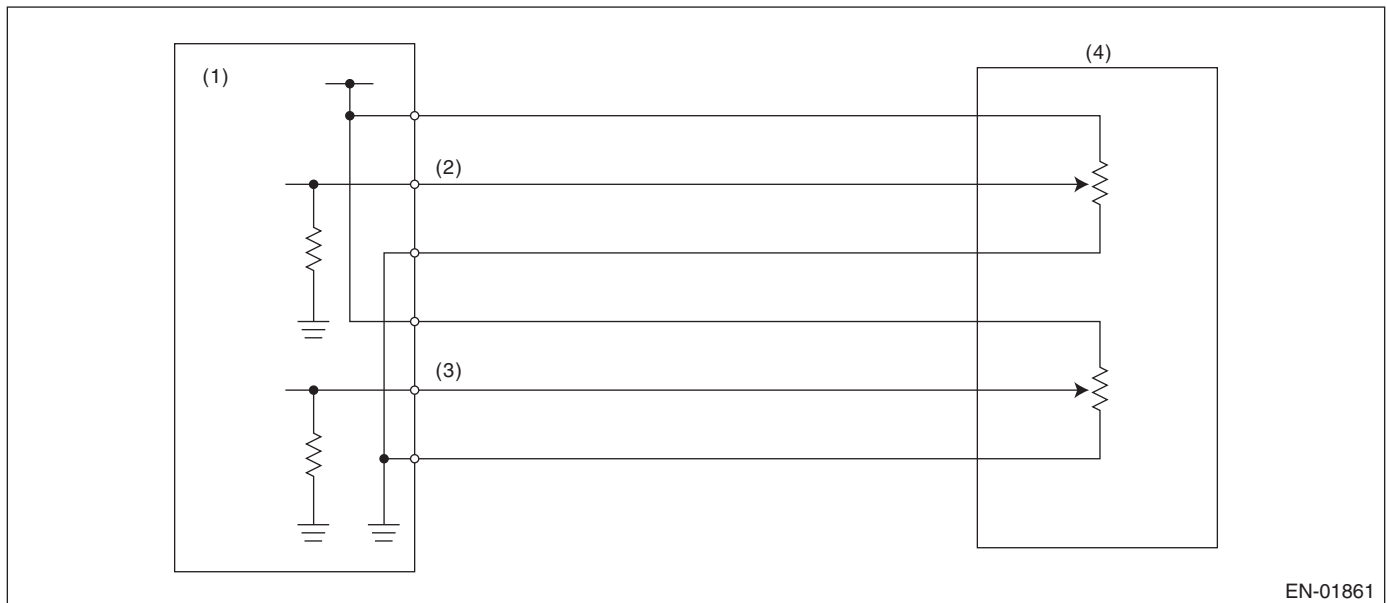

EN-01861

- | | |
|--|--|
| (1) Engine control module (ECM) | (3) Accelerator pedal position sensor 2 signal |
| (2) Accelerator pedal position sensor 1 signal | (4) Accelerator pedal position sensor |

3. ENABLE CONDITION

Secondary Parameters	Enable Conditions
Ignition switch	ON

4. GENERAL DRIVING CYCLE

Always perform the diagnosis continuously.

5. DIAGNOSTIC METHOD

Judge OK and clear the NG when the malfunction criteria below are completed.

Judgment Value

Malfunction Criteria	Threshold Value
Sensor 1 input voltage	≥ 0.219 V

Diagnostic Trouble Code (DTC) Detecting Criteria

GENERAL DESCRIPTION

Time Needed for Diagnosis: 100 milliseconds

Malfunction Indicator Light Illumination: Illuminates as soon as malfunction occurs.

6. DTC CLEAR CONDITION

- When the OK idling cycle was completed 40 times in a row
- When "Clear Memory" was performed (Only with engine stopped)

7. MALFUNCTION INDICATOR LIGHT CLEAR CONDITION

- When the OK driving cycle was completed 3 times in a row
- When "Clear Memory" was performed (Only with engine stopped)

8. FAIL SAFE

- Single malfunction: Control with normal sensor
- Multi malfunction: Fix the throttle opening angle to 6°.

9. ECM OPERATION AT DTC SETTING

Memorize the freeze frame data. (For test mode \$02)

Diagnostic Trouble Code (DTC) Detecting Criteria

GENERAL DESCRIPTION

EG:DTC P2123 THROTTLE/PEDAL POSITION SENSOR/SWITCH “D” CIRCUIT HIGH INPUT

1. OUTLINE OF DIAGNOSIS

Detect the open or short circuit of accelerator pedal position sensor 1.
Judge NG when out of the standard value.

2. COMPONENT DESCRIPTION

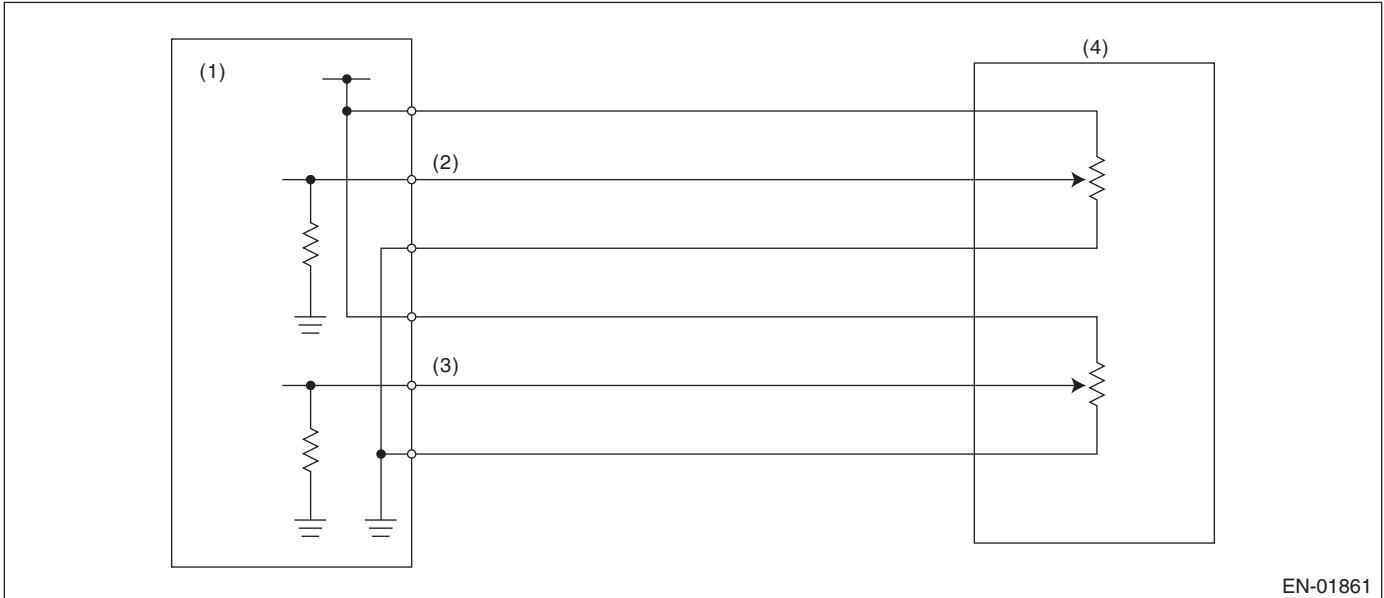

- | | |
|--|--|
| (1) Engine control module (ECM) | (3) Accelerator pedal position sensor 2 signal |
| (2) Accelerator pedal position sensor 1 signal | (4) Accelerator pedal position sensor |

3. ENABLE CONDITION

Secondary Parameters	Enable Conditions
Ignition switch	ON

4. GENERAL DRIVING CYCLE

Always perform the diagnosis continuously.

5. DIAGNOSTIC METHOD

Judge OK and clear the NG when the malfunction criteria below are completed.

Judgment Value

Malfunction Criteria	Threshold Value
Sensor 1 input voltage	≤ 4.781 V

Time Needed for Diagnosis: 100 milliseconds

Malfunction Indicator Light Illumination: Illuminates as soon as malfunction occurs.

6. DTC CLEAR CONDITION

- When the OK idling cycle was completed 40 times in a row
- When “Clear Memory” was performed (Only with engine stopped)

7. MALFUNCTION INDICATOR LIGHT CLEAR CONDITION

- When the OK driving cycle was completed 3 times in a row
- When “Clear Memory” was performed (Only with engine stopped)

8. FAIL SAFE

- Single malfunction: Control with normal sensor
- Multi malfunction: Fix the throttle opening angle to 6°.

9. ECM OPERATION AT DTC SETTING

Memorize the freeze frame data. (For test mode \$02)

EH:DTC P2127 THROTTLE/PEDAL POSITION SENSOR/SWITCH “E” CIRCUIT LOW INPUT

1. OUTLINE OF DIAGNOSIS

Detect the open or short circuit of accelerator pedal position sensor 2.
Judge NG when out of the standard value.

2. COMPONENT DESCRIPTION

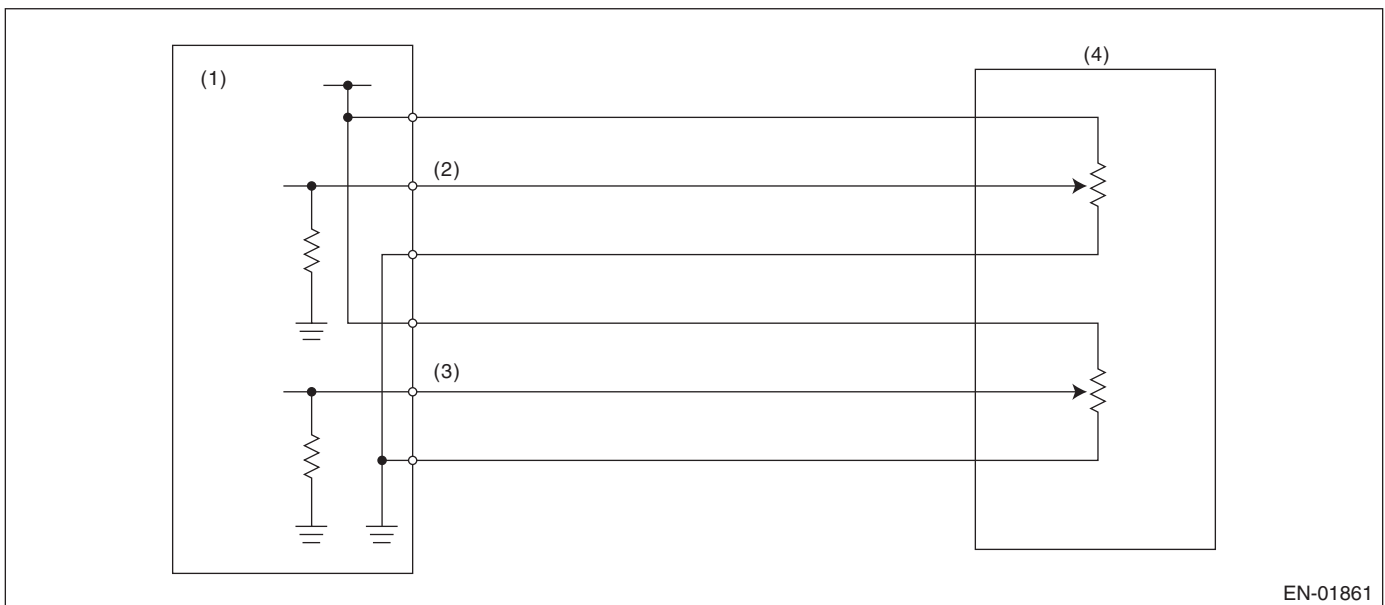

EN-01861

- | | |
|--|---------------------------------------|
| (1) Engine control module (ECM) | (3) Accelerator pedal position sensor |
| (2) Accelerator pedal position sensor 1 signal | 2 signal |
| | (4) Accelerator pedal position sensor |

3. ENABLE CONDITION

Secondary Parameters	Enable Conditions
Ignition switch	ON

4. GENERAL DRIVING CYCLE

Always perform the diagnosis continuously.

5. DIAGNOSTIC METHOD

Judge OK and clear the NG when the malfunction criteria below are completed.

Judgment Value

Malfunction Criteria	Threshold Value
Sensor 1 input voltage	≥ 0.219 V

Time Needed for Diagnosis: 100 milliseconds

Malfunction Indicator Light Illumination: Illuminates as soon as malfunction occurs.

Diagnostic Trouble Code (DTC) Detecting Criteria

GENERAL DESCRIPTION

6. DTC CLEAR CONDITION

- When the OK idling cycle was completed 40 times in a row
- When "Clear Memory" was performed (Only with engine stopped)

7. MALFUNCTION INDICATOR LIGHT CLEAR CONDITION

- When the OK driving cycle was completed 3 times in a row
- When "Clear Memory" was performed (Only with engine stopped)

8. FAIL SAFE

- Single malfunction: Control with normal sensor
- Multi malfunction: Fix the throttle opening angle to 6°.

9. ECM OPERATION AT DTC SETTING

Memorize the freeze frame data. (For test mode \$02)

EI: DTC P2128 THROTTLE/PEDAL POSITION SENSOR/SWITCH “E” CIRCUIT HIGH INPUT

1. OUTLINE OF DIAGNOSIS

Detect the open or short circuit of accelerator pedal position sensor 2.
Judge NG when out of the standard value.

2. COMPONENT DESCRIPTION

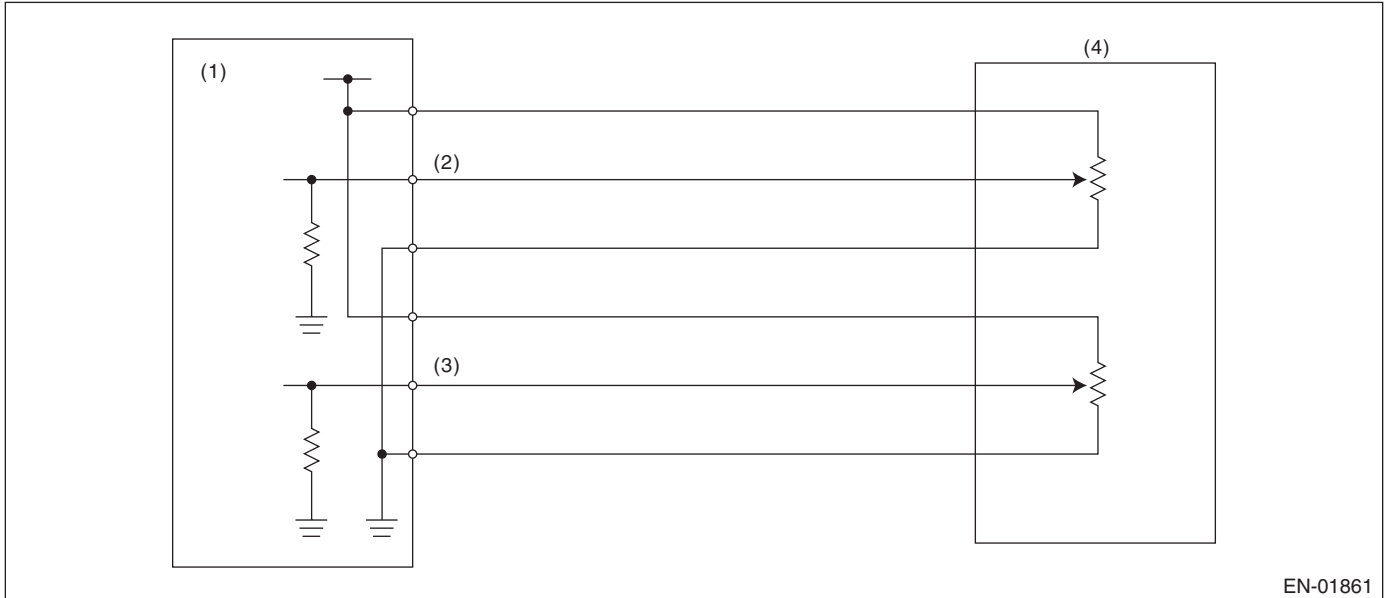

- | | |
|--|--|
| (1) Engine control module (ECM) | (3) Accelerator pedal position sensor 2 signal |
| (2) Accelerator pedal position sensor 1 signal | (4) Accelerator pedal position sensor |

3. ENABLE CONDITION

Secondary Parameters	Enable Conditions
Ignition switch	ON

4. GENERAL DRIVING CYCLE

Always perform the diagnosis continuously.

5. DIAGNOSTIC METHOD

Judge OK and clear the NG when the malfunction criteria below are completed.

Judgment Value

Malfunction Criteria	Threshold Value
Sensor 1 input voltage	$\leq 4.781 \text{ V}$

Time Needed for Diagnosis: 100 milliseconds

Malfunction Indicator Light Illumination: Illuminates as soon as malfunction occurs.

6. DTC CLEAR CONDITION

- When the OK idling cycle was completed 40 times in a row
- When “Clear Memory” was performed (Only with engine stopped)

7. MALFUNCTION INDICATOR LIGHT CLEAR CONDITION

- When the OK driving cycle was completed 3 times in a row
- When “Clear Memory” was performed (Only with engine stopped)

Diagnostic Trouble Code (DTC) Detecting Criteria

GENERAL DESCRIPTION

8. FAIL SAFE

- Single malfunction: Control with normal sensor
- Multi malfunction: Fix the throttle opening angle to 6°.

9. ECM OPERATION AT DTC SETTING

Memorize the freeze frame data. (For test mode \$02)

EJ: DTC P2135 THROTTLE/PEDAL POSITION SENSOR/SWITCH “A”/“B” VOLTAGE CORRELATION

1. OUTLINE OF DIAGNOSIS

Judge NG when the signal level of throttle position sensor 1 is different from the throttle position sensor 2.

2. COMPONENT DESCRIPTION

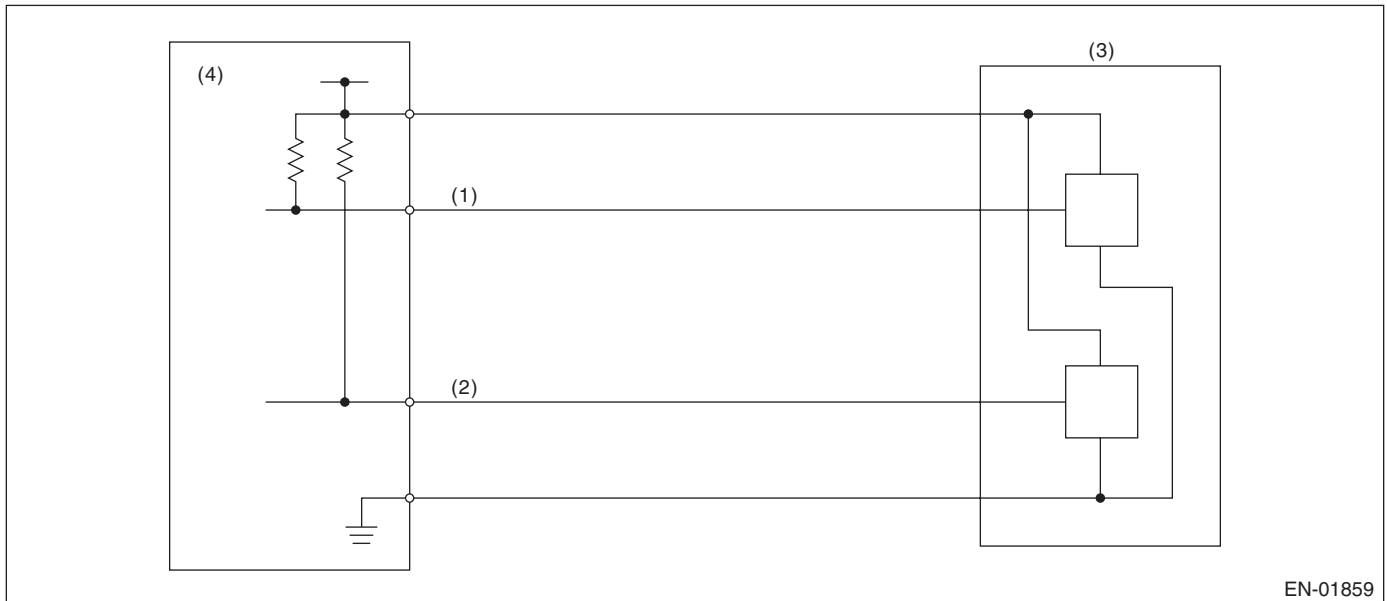

EN-01859

- (1) Throttle position sensor 1 signal (3) Throttle position sensor
 (2) Throttle position sensor 2 signal (4) Engine control module (ECM)

3. ENABLE CONDITION

Secondary Parameters	Enable Conditions
Ignition switch	ON

4. GENERAL DRIVING CYCLE

Always perform the diagnosis continuously.

5. DIAGNOSTIC METHOD

Judge OK and clear the NG when the malfunction criteria below are completed.

Judgment Value

Malfunction Criteria	Threshold Value
Signal difference between two sensors	≤ 4.25

Diagnostic Trouble Code (DTC) Detecting Criteria

GENERAL DESCRIPTION

Details of Judgment Value

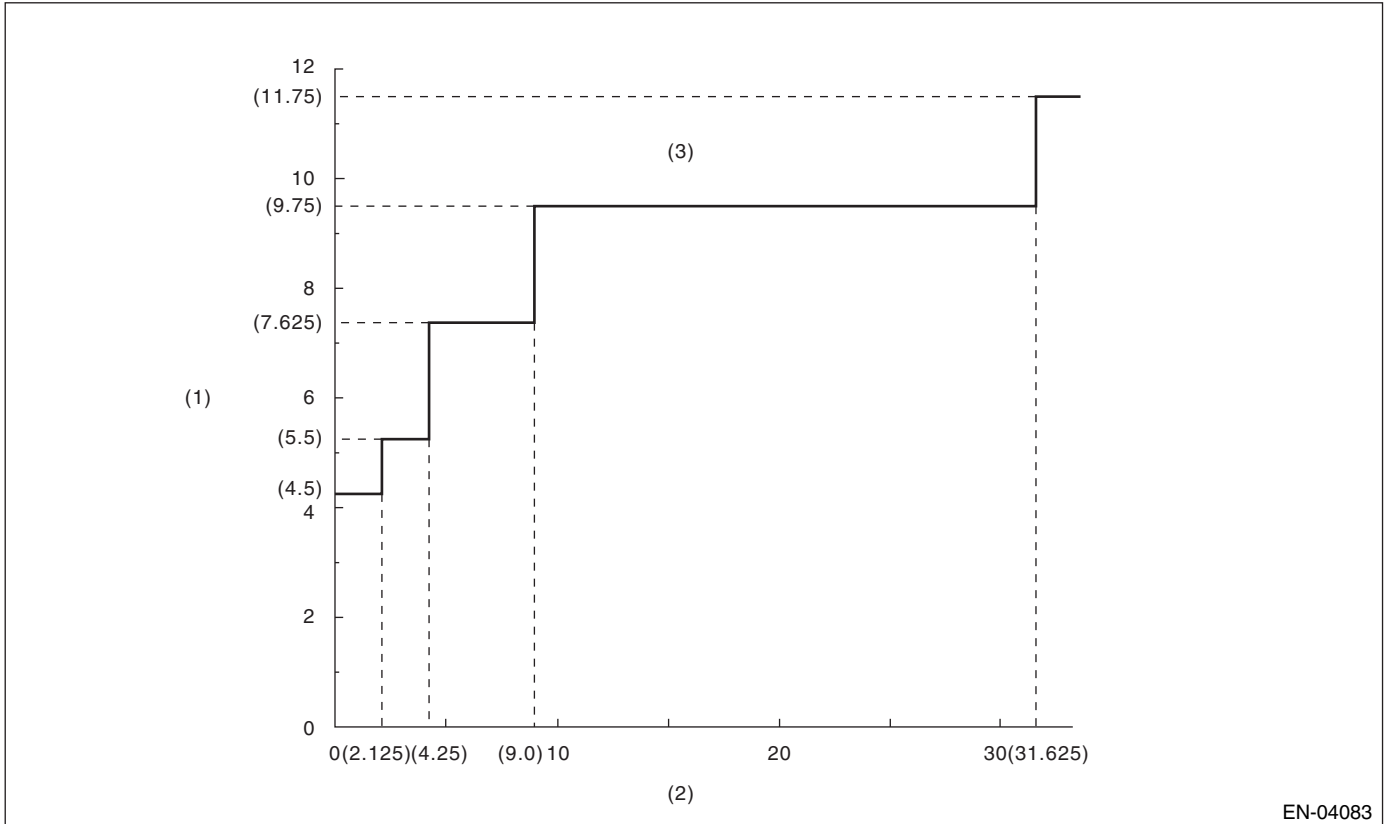

EN-04083

(1) Sensor output difference (°)

(2) Throttle position sensor 1 opening angle (°)

(3) NG area

Time Needed for Diagnosis: 212 milliseconds

Malfunction Indicator Light Illumination: Illuminates as soon as malfunction occurs.

6. DTC CLEAR CONDITION

- When the OK idling cycle was completed 40 times in a row
- When "Clear Memory" was performed (Only with engine stopped)

7. MALFUNCTION INDICATOR LIGHT CLEAR CONDITION

- When the OK driving cycle was completed 3 times in a row
- When "Clear Memory" was performed (Only with engine stopped)

8. FAIL SAFE

Stop the continuity to ETC motor. (Fix the throttle opening angle to 6°.)

9. ECM OPERATION AT DTC SETTING

Memorize the freeze frame data. (For test mode \$02)

Diagnostic Trouble Code (DTC) Detecting Criteria

GENERAL DESCRIPTION

EK:DTC P2138 THROTTLE/PEDAL POSITION SENSOR/SWITCH “D”/“E” VOLT-AGE CORRELATION

1. OUTLINE OF DIAGNOSIS

Judge NG when the signal level of throttle position sensor 1 is different from the throttle position sensor 2.

2. COMPONENT DESCRIPTION

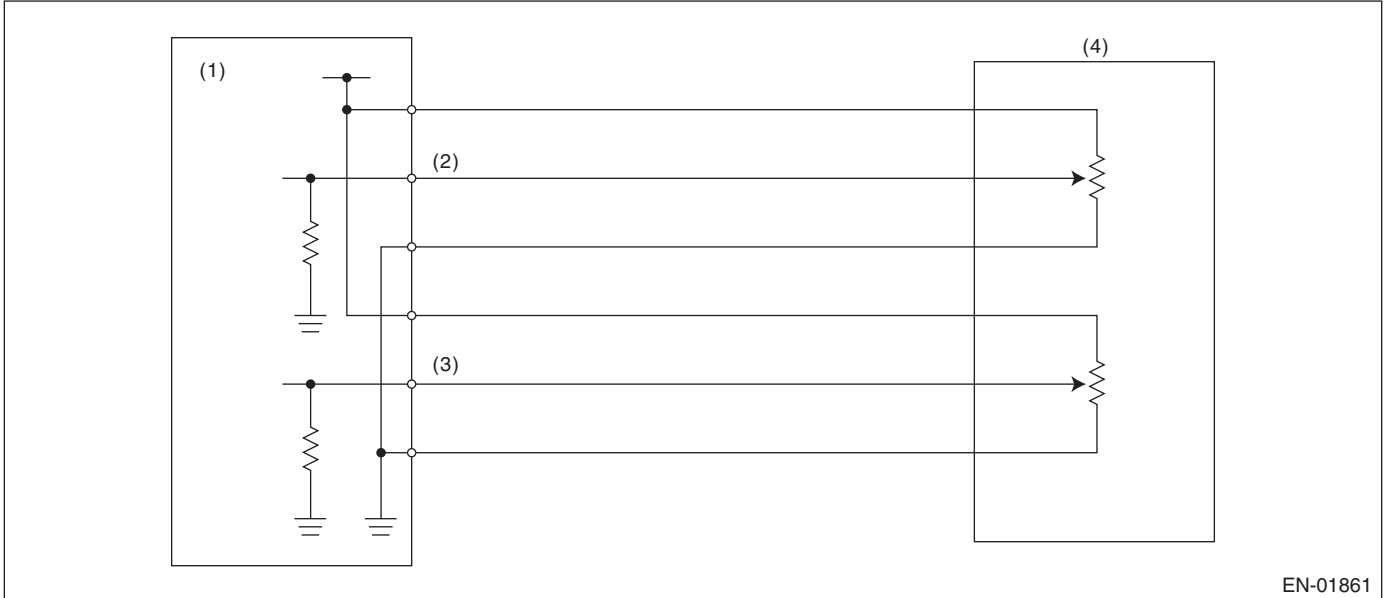

EN-01861

- | | |
|--|--|
| (1) Engine control module (ECM) | (3) Accelerator pedal position sensor 2 signal |
| (2) Accelerator pedal position sensor 1 signal | (4) Accelerator pedal position sensor |

3. ENABLE CONDITION

Secondary Parameters	Enable Conditions
Ignition switch	ON

4. GENERAL DRIVING CYCLE

Always perform the diagnosis continuously.

5. DIAGNOSTIC METHOD

Judge OK and clear the NG when the malfunction criteria below are completed.

Judgment Value

Malfunction Criteria	Threshold Value
Signal difference between two sensors	$\leq 0.77^\circ$

Diagnostic Trouble Code (DTC) Detecting Criteria

GENERAL DESCRIPTION

Details of Judgment Value

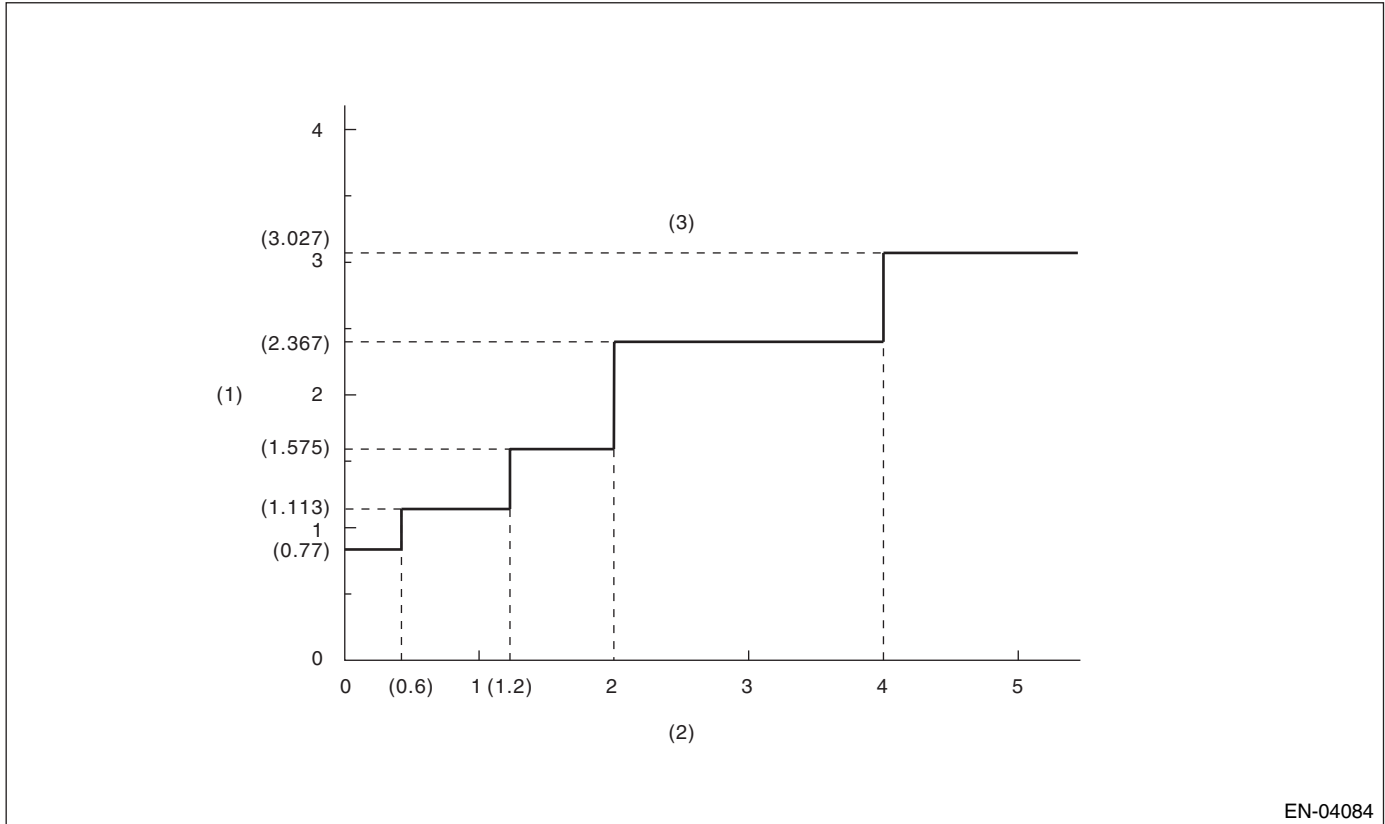

EN-04084

(1) Sensor output difference (°)

(2) Accelerator pedal position sensor
2 opening angle (°)

(3) NG area

Time Needed for Diagnosis:

- 116 milliseconds (For NG)
- 1,000 milliseconds (For OK)

Malfunction Indicator Light Illumination: Illuminates as soon as malfunction occurs.

6. DTC CLEAR CONDITION

- When the OK idling cycle was completed 40 times in a row
- When "Clear Memory" was performed

7. MALFUNCTION INDICATOR LIGHT CLEAR CONDITION

- When the OK driving cycle was completed 3 times in a row
- When "Clear Memory" was performed

8. FAIL SAFE

Fix the throttle opening angle to 6°.

9. ECM OPERATION AT DTC SETTING

Memorize the freeze frame data. (For test mode \$02)

Diagnostic Trouble Code (DTC) Detecting Criteria

GENERAL DESCRIPTION

EL:DTC P2227 BAROMETRIC PRESSURE TOO LOW

1. OUTLINE OF DIAGNOSIS

Detect the malfunction of atmospheric pressure sensor output property. Judge NG when the atmospheric pressure sensor output is largely different from the intake manifold pressure at engine starting.

2. COMPONENT DESCRIPTION

Atmospheric pressure sensor is built in ECM.

3. ENABLE CONDITION

Secondary Parameters	Enable Conditions
Engine speed at engine starting	< 300 rpm
Vehicle speed	< 1 km/h (1 MPH)

4. GENERAL DRIVING CYCLE

Perform the diagnosis once before engine starting with the ignition switch ON.

5. DIAGNOSTIC METHOD

• Abnormality Judgment

Judge NG when the continuous time of completing the malfunction criteria below becomes more than 0.3 seconds.

Judgment Value

Malfunction Criteria	Threshold Value
Atmospheric – manifold absolute pressure	≥ 26.7 kPa (200 mmHg, 7.88 inHg)
Intake manifold pressure at engine starting – manifold absolute pressure	< 1.33 kPa (10 mmHg, 2.95 inHg)

Time Needed for Diagnosis: 0.3 seconds

Malfunction Indicator Light Illumination: Detect when malfunction occurs in 2 continuous driving cycles.

• Normality Judgment

Judge OK and clear the NG when the continuous time of completing the malfunction criteria below becomes more than 0.26 seconds.

Judgment Value

Malfunction Criteria	Threshold Value
Atmospheric – manifold absolute pressure	< 26.7 kPa (200 mmHg, 7.88 inHg)

6. DTC CLEAR CONDITION

- When the OK idling cycle was completed 40 times in a row
- When "Clear Memory" was performed

7. MALFUNCTION INDICATOR LIGHT CLEAR CONDITION

- When the OK driving cycle was completed 3 times in a row
- When "Clear Memory" was performed

8. FAIL SAFE

Atmospheric pressure sensor process: Fix the atmospheric pressure to 101.3 kPa (760 mmHg, 29.8 inHg).

9. ECM OPERATION AT DTC SETTING

Memorize the freeze frame data. (For test mode \$02)

Diagnostic Trouble Code (DTC) Detecting Criteria

GENERAL DESCRIPTION

EM:DTC P2228 ATMOSPHERIC PRESSURE SENSOR CIRCUIT MALFUNCTION (LOW INPUT)

1. OUTLINE OF DIAGNOSIS

Detect the open or short circuit of atmospheric pressure sensor.
Judge NG when out of the standard value.

2. COMPONENT DESCRIPTION

Atmospheric pressure sensor is built in ECM.

3. ENABLE CONDITION

Secondary Parameters	Enable Conditions
None	

4. GENERAL DRIVING CYCLE

Always perform the diagnosis continuously.

5. DIAGNOSTIC METHOD

• Abnormality Judgment

Judge NG when the continuous time of completing the malfunction criteria below becomes more than 0.5 seconds.

Judgment Value

Malfunction Criteria	Threshold Value
Ignition switch	ON
Output voltage	< 0.118 V

Time Needed for Diagnosis: 0.5 seconds

Malfunction Indicator Light Illumination: Illuminates as soon as malfunction occurs.

• Normality Judgment

Judge OK and clear the NG when the malfunction criteria below are completed.

Judgment Value

Malfunction Criteria	Threshold Value
Ignition switch	ON
Output voltage	≥ 0.118 V

6. DTC CLEAR CONDITION

- When the OK idling cycle was completed 40 times in a row
- When "Clear Memory" was performed

7. MALFUNCTION INDICATOR LIGHT CLEAR CONDITION

- When the OK driving cycle was completed 3 times in a row
- When "Clear Memory" was performed

8. FAIL SAFE

Atmospheric pressure sensor process: Fix the atmospheric pressure to 101.3 kPa (760 mmHg, 29.9 inHg).

9. ECM OPERATION AT DTC SETTING

Memorize the freeze frame data. (For test mode \$02)

Diagnostic Trouble Code (DTC) Detecting Criteria

GENERAL DESCRIPTION

EN:DTC P2229 ATMOSPHERIC PRESSURE SENSOR CIRCUIT MALFUNCTION (HIGH INPUT)

1. OUTLINE OF DIAGNOSIS

Detect the open or short circuit of atmospheric pressure sensor.
Judge NG when out of the standard value.

2. COMPONENT DESCRIPTION

Atmospheric pressure sensor is built in ECM.

3. ENABLE CONDITION

Secondary Parameters	Enable Conditions
None	

4. GENERAL DRIVING CYCLE

Always perform the diagnosis continuously.

5. DIAGNOSTIC METHOD

• Abnormality Judgment

Judge NG when the continuous time of completing the malfunction criteria below becomes more than 0.5 seconds.

Judgment Value

Malfunction Criteria	Threshold Value
Ignition switch	ON
Output voltage	≥ 4.936 V

Time Needed for Diagnosis: 0.5 seconds

Malfunction Indicator Light Illumination: Illuminates as soon as malfunction occurs.

• Normality Judgment

Judge OK and clear the NG when the malfunction criteria below are completed.

Judgment Value

Malfunction Criteria	Threshold Value
Ignition switch	ON
Output voltage	< 4.936 V

6. DTC CLEAR CONDITION

- When the OK idling cycle was completed 40 times in a row
- When "Clear Memory" was performed

7. MALFUNCTION INDICATOR LIGHT CLEAR CONDITION

- When the OK driving cycle was completed 3 times in a row
- When "Clear Memory" was performed

8. FAIL SAFE

Atmospheric pressure sensor process: Fix the atmospheric pressure to 101.3 kPa (760 mmHg, 29.9 inHg).

9. ECM OPERATION AT DTC SETTING

Memorize the freeze frame data. (For test mode \$02)

Diagnostic Trouble Code (DTC) Detecting Criteria

GENERAL DESCRIPTION

EO:DTC P2431 SECONDARY AIR INJECTION SYSTEM AIR FLOW / PRESSURE SENSOR CIRCUIT RANGE / PERFORMANCE

1. OUTLINE OF DIAGNOSIS

Detect the malfunction of secondary air pressure sensor output property.

Judge NG when the secondary air pressure sensor output is largely different from the intake manifold pressure at engine starting.

2. ENABLE CONDITION

Secondary Parameters	Enable Conditions
Engine speed at starting	< 300 rpm
Vehicle speed	< 1 km/h
After secondary air injection system is stopped	More than 3 seconds

3. GENERAL DRIVING CYCLE

Perform the diagnosis with ignition switch ON.

4. DIAGNOSTIC METHOD

• Abnormality Judgment

Judge NG when the continuous time of completing the malfunction criteria below becomes more than 0.3 seconds.

Judgment Value

Malfunction Criteria	Threshold Value
Secondary air pipe pressure - Intake manifold pressure	≥ 200 mmHg
Intake manifold pressure at starting - Intake manifold pressure	< 10 mmHg

Time Needed for Diagnosis: 0.3 seconds

Malfunction Indicator Light Illumination: Illuminates when malfunction occurs in 2 continuous driving cycles.

• Normality Judgment

Judge OK and clear the NG when the continuous time of completing the malfunction criteria below becomes more than 0.26 seconds.

Judgment Value

Malfunction Criteria	Threshold Value
Secondary air pipe pressure - Intake manifold pressure	< 200 mmHg

5. DTC CLEAR CONDITION

- When the OK idling cycle was completed 40 times in a row
- When "Clear Memory" was performed

6. MALFUNCTION INDICATOR LIGHT CLEAR CONDITION

- When the OK driving cycle was completed 3 times in a row
- When "Clear Memory" was performed

7. FAIL SAFE

None

8. ECM OPERATION AT DTC SETTING

Memorize the freeze frame data. (For test mode \$02)

Diagnostic Trouble Code (DTC) Detecting Criteria

GENERAL DESCRIPTION

EP:DTC P2432 SECONDARY AIR INJECTION SYSTEM AIR FLOW / PRESSURE SENSOR CIRCUIT LOW

1. OUTLINE OF DIAGNOSIS

Judge NG when out of the standard value.

2. ENABLE CONDITION

Secondary Parameters	Enable Conditions
OFF	

3. GENERAL DRIVING CYCLE

Always perform the diagnosis continuously.

4. DIAGNOSTIC METHOD

• Abnormality Judgment

Judge NG when the continuous time of completing the malfunction criteria below becomes more than 0.5 seconds.

Judgment Value

Malfunction Criteria	Threshold Value
Ignition switch	ON
Output voltage	< 0.568 V

Time Needed for Diagnosis: 0.5 seconds

Malfunction Indicator Light Illumination: Illuminates when malfunction occurs.

• Normality Judgment

Judge OK and clear the NG when the malfunction criteria below are completed.

Judgment Value

Malfunction Criteria	Threshold Value
Ignition switch	ON
Output voltage	≥ 0.568 V

5. DTC CLEAR CONDITION

- When the OK idling cycle was completed 40 times in a row
- When "Clear Memory" was performed

6. MALFUNCTION INDICATOR LIGHT CLEAR CONDITION

- When the OK driving cycle was completed 3 times in a row
- When "Clear Memory" was performed

7. FAIL SAFE

None

8. ECM OPERATION AT DTC SETTING

Memorize the freeze frame data. (For test mode \$02)

Diagnostic Trouble Code (DTC) Detecting Criteria

GENERAL DESCRIPTION

EQ:DTC P2433 SECONDARY AIR INJECTION SYSTEM AIR FLOW / PRESSURE SENSOR CIRCUIT HIGH

1. OUTLINE OF DIAGNOSIS

Judge NG when out of the standard value.

2. ENABLE CONDITION

Secondary Parameters	Enable Conditions
OFF	

3. GENERAL DRIVING CYCLE

Always perform the diagnosis continuously.

4. DIAGNOSTIC METHOD

• Abnormality Judgment

Judge NG when the continuous time of completing the malfunction criteria below becomes more than 0.5 seconds.

Judgment Value

Malfunction Criteria	Threshold Value
Ignition switch	ON
Output voltage	≥ 4.921 V

Time Needed for Diagnosis: 0.5 seconds

Malfunction Indicator Light Illumination: Illuminates when malfunction occurs.

• Normality Judgment

Judge OK and clear the NG when the malfunction criteria below are completed.

Judgment Value

Malfunction Criteria	Threshold Value
Ignition switch	ON
Output voltage	< 4.921 V

5. DTC CLEAR CONDITION

- When the OK idling cycle was completed 40 times in a row
- When "Clear Memory" was performed

6. MALFUNCTION INDICATOR LIGHT CLEAR CONDITION

- When the OK driving cycle was completed 3 times in a row
- When "Clear Memory" was performed

7. FAIL SAFE

None

8. ECM OPERATION AT DTC SETTING

Memorize the freeze frame data. (For test mode \$02)

Diagnostic Trouble Code (DTC) Detecting Criteria

GENERAL DESCRIPTION

ER:DTC P2440 SECONDARY AIR INJECTION SYSTEM SWITCHING VALVE STUCK OPEN (BANK1)

NOTE:

For the diagnostic procedure, refer to DTC P0410. <Ref. to GD(H4DOTC)-111, DTC P0410 SECONDARY AIR INJECTION SYSTEM, Diagnostic Trouble Code (DTC) Detecting Criteria.>

ES:DTC P2441 SECONDARY AIR INJECTION SYSTEM SWITCHING VALVE STUCK CLOSED (BANK1)

NOTE:

For the diagnostic procedure, refer to DTC P0410. <Ref. to GD(H4DOTC)-111, DTC P0410 SECONDARY AIR INJECTION SYSTEM, Diagnostic Trouble Code (DTC) Detecting Criteria.>

ET:DTC P2442 SECONDARY AIR INJECTION SYSTEM SWITCHING VALVE STUCK OPEN (BANK2)

NOTE:

For the diagnostic procedure, refer to DTC P0410. <Ref. to GD(H4DOTC)-111, DTC P0410 SECONDARY AIR INJECTION SYSTEM, Diagnostic Trouble Code (DTC) Detecting Criteria.>

EU:DTC P2443 SECONDARY AIR INJECTION SYSTEM SWITCHING VALVE STUCK CLOSED (BANK2)

NOTE:

For the diagnostic procedure, refer to DTC P0410. <Ref. to GD(H4DOTC)-111, DTC P0410 SECONDARY AIR INJECTION SYSTEM, Diagnostic Trouble Code (DTC) Detecting Criteria.>

Diagnostic Trouble Code (DTC) Detecting Criteria

GENERAL DESCRIPTION

EV:DTC P2444 SECONDARY AIR INJECTION SYSTEM PUMP STUCK ON

1. OUTLINE OF DIAGNOSIS

Detect the malfunction (always ON) of secondary air pump.

Judge NG when the secondary air supply pipe pressure is higher than atmospheric pressure.

2. ENABLE CONDITION

Secondary Parameters	Enable Conditions
OFF	

3. GENERAL DRIVING CYCLE

Always perform the diagnosis continuously.

4. DIAGNOSTIC METHOD

Judge NG when the secondary air supply pipe pressure is higher than atmospheric pressure though it should become atmospheric pressure with the secondary air pump OFF.

• Abnormality Judgment

Judge NG when the continuous time of completing the malfunction criteria below becomes more than 5 seconds.

Judgment Value

Malfunction Criteria	Threshold Value
Presumed ambient temperature	$\geq 4.4^{\circ}\text{C}$ (40°F)
Battery voltage	$\geq 10.9\text{ V}$
After secondary air injection system is operated	More than 0.6 seconds
Battery voltage	$\geq 7\text{ V}$
Atmospheric pressure	$\geq 75.0\text{ kPa}$ (563 mmHg, 22.15 inHg)
Engine	In operation
After secondary air injection system is stopped	More than 3 seconds
Secondary air pipe pressure (absolute pressure)	$>$ Value of Map 22

Diagnostic Trouble Code (DTC) Detecting Criteria

GENERAL DESCRIPTION

Map 22

Unit: kPa (mmHg, inHg)		Ambient pressure (kPa (mmHg, inHg))							
		69.3 (520, 20.47)	74.6 (560, 22.03)	80.0 (600, 23.63)	85.3 (640, 25.19)	90.6 (680, 26.76)	96.0 (720, 28.35)	101.3 (760, 29.92)	106.6 (800, 31.48)
Battery voltage (V)	10.5	78.0 (585, 23.03)	84.0 (630, 24.80)	90.0 (675, 26.58)	96.0 (720, 28.35)	102.0 (765, 30.13)	108.0 (810, 31.90)	114.0 (855, 33.67)	120.0 (900, 35.44)
	11.5	79.3 (595, 23.42)	85.4 (641, 25.22)	91.6 (687, 27.05)	97.7 (733, 28.86)	103.7 (778, 30.63)	109.8 (824, 32.43)	116.0 (870, 34.26)	122.1 (916, 36.06)
	12.5	80.8 (606, 23.86)	86.9 (652, 25.67)	93.2 (699, 27.53)	99.3 (745, 29.33)	105.6 (792, 31.19)	111.7 (838, 32.99)	118.0 (885, 34.85)	124.2 (932, 36.68)
	13.5	82.1 (616, 24.25)	88.4 (663, 26.11)	94.8 (711, 28.0)	101.0 (758, 29.83)	107.3 (805, 31.69)	113.7 (853, 33.58)	120.0 (900, 35.44)	126.2 (947, 37.27)
	14.5	83.4 (626, 24.63)	89.8 (674, 26.52)	96.2 (722, 28.41)	102.8 (771, 30.36)	109.2 (819, 32.25)	115.6 (867, 34.14)	122.0 (915, 36.03)	128.4 (963, 37.92)
	15.5	84.8 (636, 25.05)	89.8 (685, 26.52)	97.8 (734, 28.89)	104.4 (783, 30.83)	110.9 (832, 32.75)	117.4 (881, 34.67)	124.0 (930, 36.62)	130.5 (979, 68.54)

Time Needed for Diagnosis: 5 seconds

Malfunction Indicator Light Illumination: Illuminates when malfunction occurs.

• Normality Judgment

Judge OK and clear the NG when the continuous time of completing the malfunction criteria below becomes more than 5 seconds.

Judgment Value

Malfunction Criteria	Threshold Value
Presumed ambient temperature	≥ 4.4°C (40°F)
Battery voltage	≥ 10.9 V
After secondary air injection system is operated	More than 0.6 seconds
Battery voltage	≥ 7 V
Atmospheric pressure	≥ 75.0 kPa (563 mmHg, 22.15 inHg)
Engine	In operation
After secondary air injection system is stopped	More than 3 seconds
Secondary air pipe pressure (absolute pressure)	≤ Value of Map 22

5. DTC CLEAR CONDITION

- When the OK idling cycle was completed 40 times in a row
- When "Clear Memory" was performed

6. MALFUNCTION INDICATOR LIGHT CLEAR CONDITION

- When the OK driving cycle was completed 3 times in a row
- When "Clear Memory" was performed

7. FAIL SAFE

None

8. ECM OPERATION AT DTC SETTING

Memorize the freeze frame data. (For test mode \$02)